

Der gute Ton im richtigen Licht



SACHER MUSIC GmbH - Hauptstrasse 18 - 4450 Sissach  
TEL 061 205 93 80 - MAIL info@sachermusic.ch

Audiophony

# PUBLIC ADDRESS

Commercial Audio

AUDIOPHONY COMMERCIAL AUDIO CATALOGUE 2019 & 2020





## **THE AUDIOPHONY COMMERCIAL AUDIO RANGE**

You have products that are easy to use and adapted to all the constraints of installation in indoor or outdoor spaces.

Our know-how in the professional and institutional fields allows you to enjoy a good sound, no matter where you install it.

Modern wall interfaces combined with our curved loudspeakers perfectly position themselves in places where aesthetics and discretion are important.

The 8x8 matrix and all the dedicated interfaces make it possible to respond to installations in large volumes where each zone must work completely independently.

Our choice of ceiling speakers, columns, speakers and rocks will fit into the decor for a beautiful and discreet sound presence.

Finally, we have a “magnetic loop” section to make culture and information accessible to people with disabilities, which is mandatory in public places since the “disability” law of February 2005.

**This is why we created**

**AUDIOPHONY PA Commercial Audio.**



**DISTRIBUTED BY:**

**HITMUSIC SAS**  
PARC ACTIVITÉS CAHORS SUD  
ENTESTE  
46230 FONTANES  
FRANCE

# AUDIOPHONY® COMMERCIAL AUDIO

2019 /  
2020





# Summary

|   |     |
|---|-----|
| <b>Multi-media players</b>              | 12  |
| <b>Analog matrix</b>                    | 16  |
| <b>Microphone desk</b>                  | 18  |
| <b>Wall controllers</b>                 | 20  |
| <b>Mixers</b>                           | 12  |
| <b>Amplified mixers</b>                 | 28  |
| <b>Active ceiling speakers</b>          | 46  |
| <b>Discrete speakers IP66</b>           | 48  |
| <b>Sound projectors</b>                 | 52  |
| <b>HiFi speakers</b>                    | 60  |
| <b>Ceiling speakers</b>                 | 74  |
| <b>Square ceiling speakers</b>          | 94  |
| <b>Wide-diffusion discrete speakers</b> | 98  |
| <b>Triphonic systems</b>                | 102 |
| <b>Magnetic induction loop</b>          | 108 |

## On the terrace

The “Commercial Audio” series brings you adequate solutions for any outdoor installation and wet locations. Our solutions are able to create the mood anywhere with a powerful HiFi output. Integrate them to either mono or multi-source systems to use them indoor or outdoor.

Our tropicalized speakers benefit from a refined design, whereas the specific treatment of housings and loudspeakers guarantee a perfect fit in any installation, even in wet, complicated situations.



Find this pictogram for usable products outdoors.









## Cosily

Subtle and elegant devices perfect for relaxation and party places. They are compatible with almost every audio device, and different models are available to perfectly suit your installation.

Each component has been designed so the speaker fully integrates your project or installation. Our famous speakers, recessed amplifiers and multimedia systems will meet even the most demanding installation standards.



This pictogram is there to help you to choose a product according to its sound quality.







## In your shop

Our very discreet and intuitive solutions made for commercial premises guarantee you an even sound distribution, a high-quality output at low volume and clear, intelligible voices. You will benefit of an excellent value for money principle for places combining announcements and music.

We provide you with a vast range of multiple broadcast with zone management devices to allow you to perfectly control every area.



This pictogram shows you the products that can be used in retail spaces.







## Public spaces

You will benefit of an excellent value for money principle for places combining announcements and music. We provide you with a vast range of multiple broadcast technologies, with a zone management to allow you to perfectly control every area.

The “Commercial Audio” series provides you with many ways to implement an indoor or outdoor sound system. It has been designed to broadcast public announcements and background music with a constant quality and a high reliability.

We have a lot of knowledge of the industry, commercial and corporate sectors and we share it with you via a whole range of products putting yourself at the heart of a safe, simple and coherent sound system.

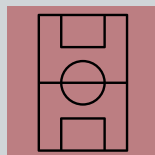

This pictogram shows you the products recommended and applicable for large indoor and outdoor spaces.









# Multimedia and mp3 compatible Tuner/CD/USB/SD/BT player



## MPU130BT

Multimedia and mp3 compatible Tuner/CD/USB/SD/BT player

- AVM protected USB/Mp3 player
- Bluetooth 2.1
- USB reader with a USB mass storage output (at the front, max 16Go, FAT32 formatted)
- SD and SDHC reader with a front slot (16 Go max)
- Output volume control
- AM/FM Tuner with autoscans and a 10 stations memory capacity
- A button allows you to browse the repertoires and tracks
- Infrared remote control supplied
- Random or programmable playlist
- Unbalanced (-10 dB) RCA output
- Mountable in 19" wide racks and ON/OFF power switch at the front
- Dimensions : 482 x 44 x 275 mm (1x19" unit)
- Power supply : 230V, AC - 50 Hz or 12V, DC
- Weight : 3.4 kg

Code: H10961

## Source control

The MPU130T is a true multimedia centre capable of supplying a continuous sound atmosphere no matter what the source is.

It's very easy to use thanks to its single output, it can be controlled independently by remote control, or directly from the front panel. Its USB and SD ports give access to hundreds of hours of non-stop music that can be pre-programmed or read randomly.

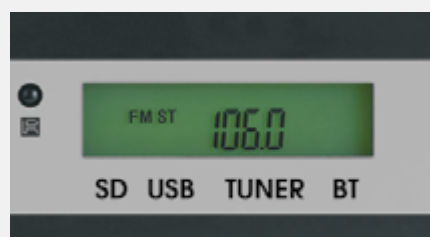



**CD SD  USB  Bluetooth™**



**Remote control functions:**

- Choice of source (CD, USB, SD or Tuner)
- Reading, stopping, jumping, searching
- Program, random and repeat functions
- Choice of folder, song and search in the file
- Choosing and storing stations
- Mute
- Ejecting the CD

# WEBradio LAN LANWIFI+FM DAB USB Reader + App



## WEBRADIO130APP

WEBradio LAN LANWIFI+FM DAB+USB Reader + App

- Radio: Ethernet /Wifi Internet radio, DAB and DAB+ digital radio, FM with RDS
- Mp3 reader: USB port for reading mp3/AAC/WMA/FLAC files on USB flash drive or FAT32 external disk drive
- Shared files: Audio file sharing available on your computer network to pool your favourite playlists
- Programmable power on:
- Infrared remote control
- Aux input on 3.5mm Jack
- Line level outputs on RCA and Headphone on 3.5mm Jack
- Power supply: 230V - 50/60Hz or DC12V
- Dimensions: 483 x 44 x 265 mm
- Net weight: 2.9 kg

Code: H10963

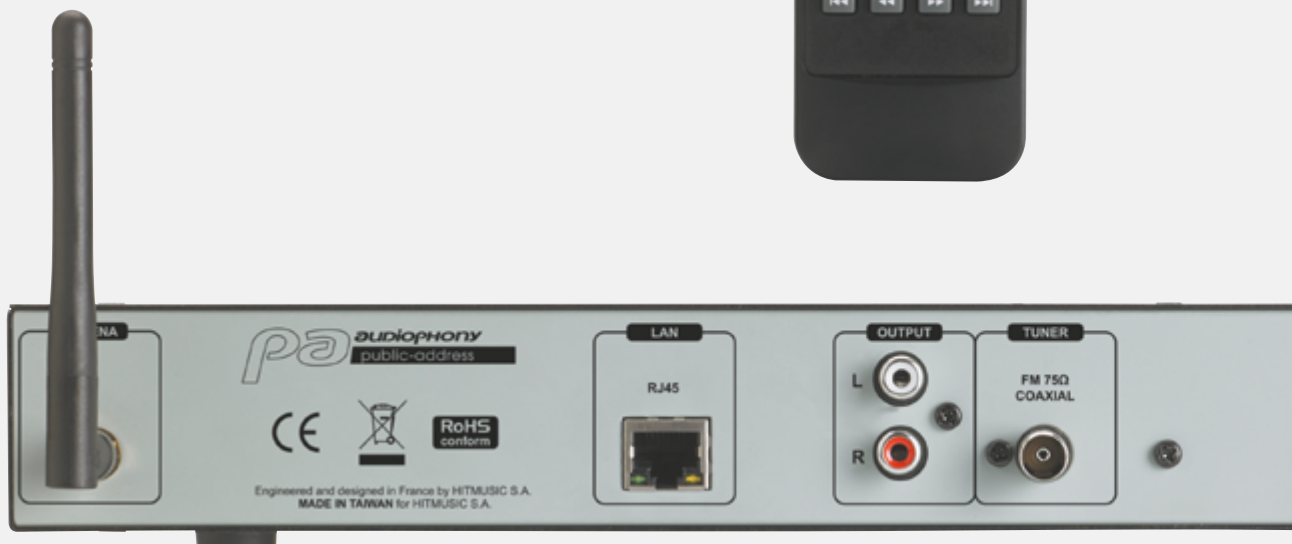





- + Internet or DAB radio for an international selection of digital music
- + USB port to play MP3 files on your hard drive
- + Share audio files on your computer network
- + Webradio control by mobile application

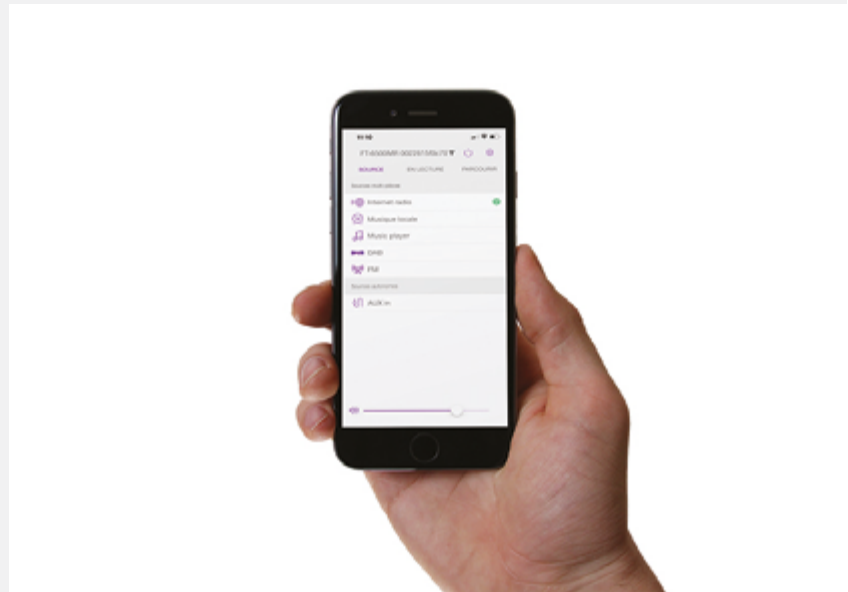

Webradio control by mobile application.  
Android and iOS compatible



# Analog matrix 8 inputs 8 outputs



## PREZONE88

Analog matrix 8 inputs 8 outputs 8 outputs

### General feature

- 8 inputs and 8 outputs with complete matrix
- 4 RJ45 connectors for MIC-DESK8M and MIC-DESK16M micro control panels
- Alert message recording system for up to 60 seconds
- Link system allowing the use of up to 4 PREZONE88 in cascade
- Priority order Announcement > Alarm > Multi-zone broadcasting > WP8 and WS8 > WP8
- Contact Mute on all outputs
- Signal indicator on each zone (-30dB)
- Output level display by zone via Vu meter 3 LEDs
- Balanced output
- Equalization 2 bands on each output (100Hz and 10KHz)

### Technical data

- Audio output 0 dB (balanced)
- Audio input: -50dB +/-3dB (balanced)
- Page mic input: -50dB +/-3dB (balanced)
- Remote mic input: -50dB +/-3dB (balanced)
- Wall control mic input: -50dB +/-3dB (balanced)
- Wall control line input: -20dB +/-3dB (unbalanced)
- 1 to 8 BGM input: -20dB +/-3dB (unbalanced)
- EQ
- Low : 100Hz: +/-12dB +/-1dB
- High : 10KHz: +/-12dB +/-1dB
- T.H.D: Less than 0.05%
- Frequency response
- Page mic input : 100Hz-10KHz +/- 3 dB
- Remote mic input : 100Hz-10KHz +/- 3 dB

- Wall control mic input : 100Hz-10KHz +/- 3 dB
- Wall control mic input : 60Hz-15KHz +/- 3 dB
- BGM : 60Hz-15KHz +/- 3 dB

- Cross talk: More than 75 dB
- Reccording time: 55 sec.
- Serial interface: Communication speed 9600bps
- RS-485: Communication distance: 300m max. (UTC cat5)
- Emergency power supply: +24VDC / 350mA
- Power supply: AC 220-240V / 50-60Hz or +24V DC
- Power consumption: 35Watts
- Weight: 5,8 Kg
- Dimensions: 482 x 132 x 315 mm

Code: H10927





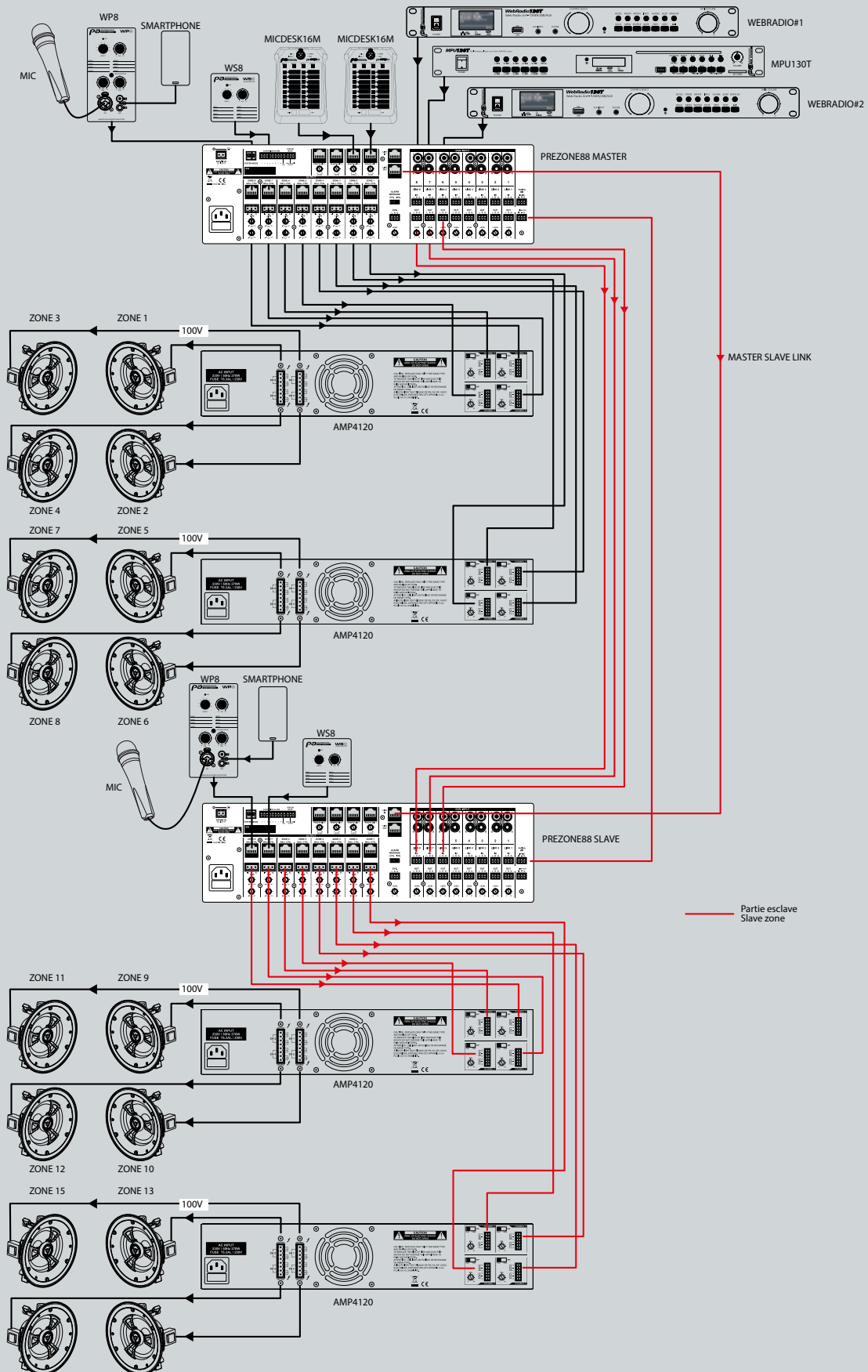

# Desk microphones for PREZONE88



## MIC-DESK16M

16-zone micro console for matrix

- 1 mic input via XLR socket on the front panel
- RJ45 rear output
- Talk button to activate the microphone (front panel)
- Chime button on the front panel
- Volume settings (Mic and Chime) via the rear panel
- Lock/unlock switch to block zones selection
- Output LED display
- Powered up via RJ45 cable from your PREZONE88

- Input sensitivity: -60 dB ± 3 dB / 600 Ohms balanced
- T.H.D: Less than 0.1%
- Frequency response: 45Hz ~ 15KHz
- Signal to noise ratio: Less than 90 dB
- Output level: 0 dB / 600 Ohms
- Weight: 0.9 Kg
- Dimensions: 140 x 60 x 205 mm

Code: H10978



## MIC-DESK8M

16-zone micro console for matrix

- 1 mic input via XLR socket on the front panel
- RJ45 rear output
- Talk button to activate the microphone (front panel)
- Chime button on the front panel
- Volume settings (Mic and Chime) via the rear panel
- Lock/unlock switch to block zones selection
- Output LED display
- Powered up via RJ45 cable from your PREZONE88

- Input sensitivity: -60 dB ± 3 dB / 600 Ohms balanced
- T.H.D: Less than 0.1%
- Frequency response: 45Hz ~ 15KHz
- Signal to noise ratio: Less than 90 dB
- Output level: 0 dB / 600 Ohms
- Weight: 0.9 Kg
- Dimensions: 140 x 60 x 205 mm

Code: H10977



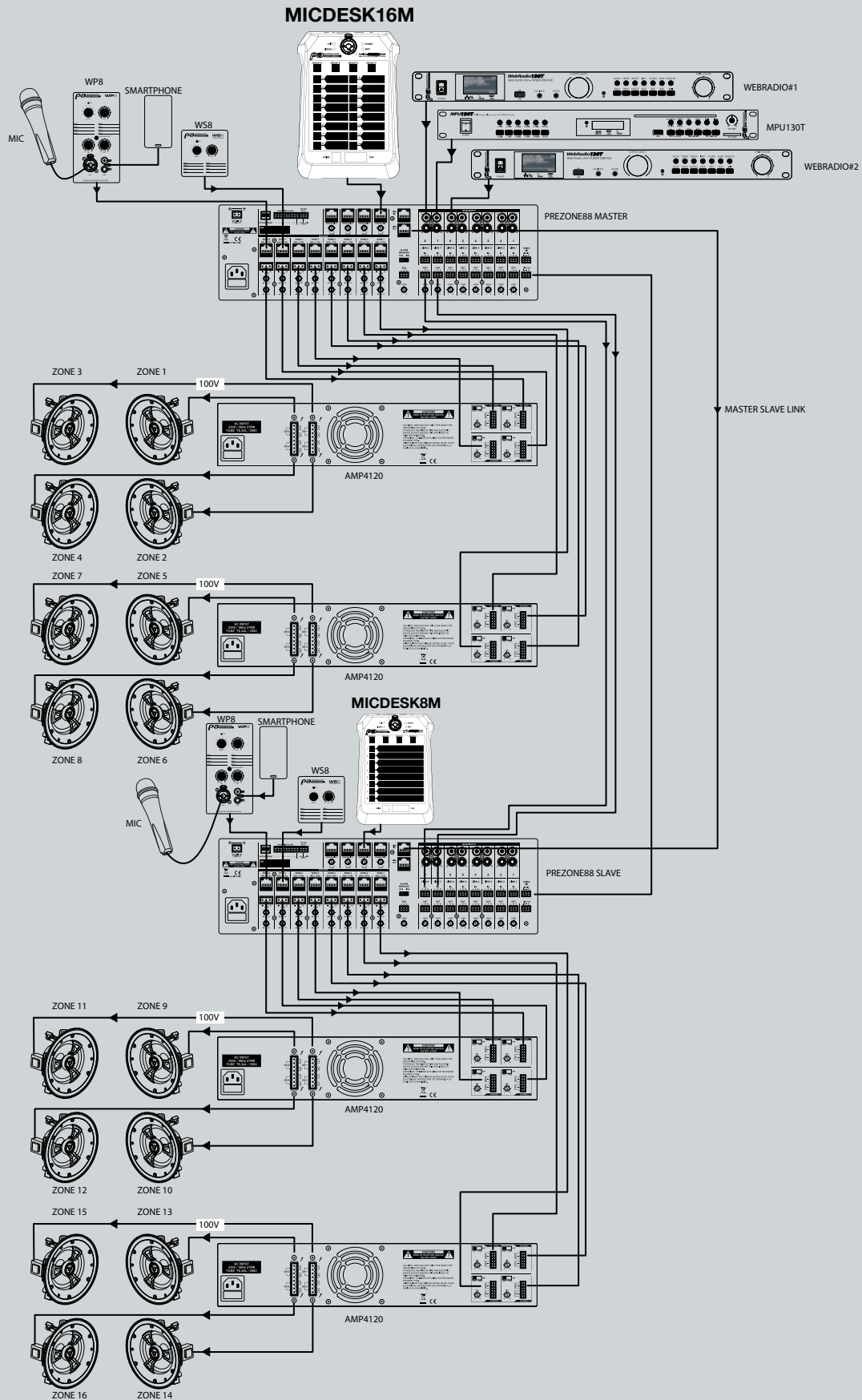

# Wall controllers with source selector for PREZONE88



## WP8

Wall controller with source selector and MIC/line input for matrix

Code: H10928



## WS8

Wall controller with source selector for matrix

Code: H10979

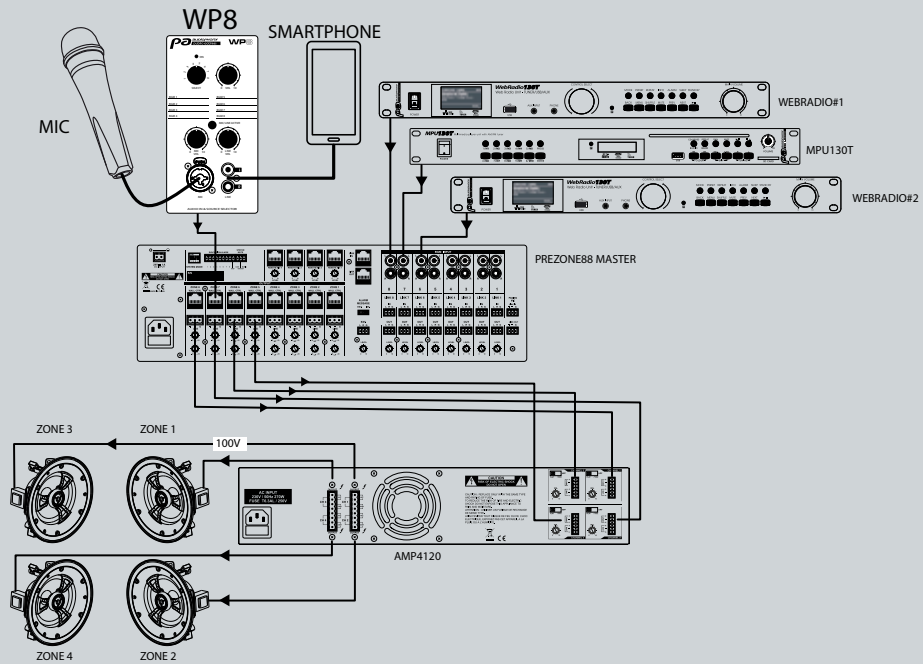
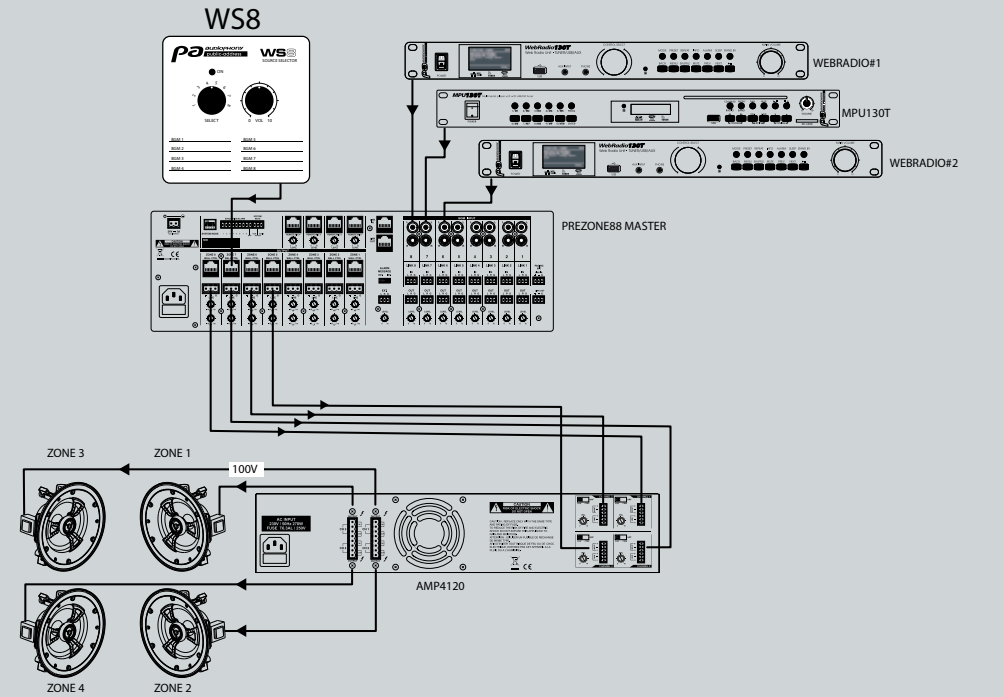



# Mixing desk- 8 channels 4 independent output zones



## PREZONE444

Mixing desk- 8 channels 4 independent output zones

- 4 symmetric Mic/Line inputs via XLR or Jack 6.35 (TRS)
- 4 stereo inputs via RCA or mono via Jack 6.35
- 4 symmetric link out outputs per zone via Phoenix plugs
- Balanced link output via Phoenix plug
- Microphone priority via input 1
- Phantom power supply for inputs 1 to 4
- Gain and tone settings (3 ways) for channels 1 to 4
- Gain settings via stereo inputs
- Tone settings (2 bands) per zone
- RJ45 Connector for WP-1 (remote input) wall controller and MIC-DESK (remote mic) for each zone
- Global Contact Mute
- Assign zones 1 to 4 to each input
- Peak and Signal display for each input
- Output display for each zone via 5-LEDVU meter
- Headphones output with volume control (zones and PFL)
- Front monitoring speaker
- Screwdriver required to access technician-level settings
- Power supply: 230V 50/60 Hz, and 24V DC
- Power consumption: 30Watts
- Back-up power supply: 24V, DC with Link Out
- Frequency response: 20Hz - 20KHz (+/-3 dB)
- T.H.D (1 kHz nominal power): < 0.1%
- Equalizer:
  - High : +/-15 dB @ 12kHz
  - Mid : +/-15 dB @ 2.5 kHz
  - Low +/- 15 dB @ 80 Hz
- Dimensions: 320 x 088 x 482 mm
- 19" Rackable
- Height: 2 units
- Weight : 5 kg

Code: H10507



### 8 INPUTS

Each input can be routed to the zone(s) of its choice.

The installer settings are accessible with a screwdriver.



### 4 OUTPUTS

The PREZONE444 is equipped with a monitoring loudspeaker to check the signal sent to each output.



### WP-1

Wall-mounted controller for ZONEAMP4120 or PREZONE444

- 1 front panel XLR microphone input
- 1 front panel RCA line input
- 1 back panel RJ45 connection
- Front panel volume control
- ON/OFF Switch
- Source display shown by LED
- DC15V power by RJ45 cable from the ZONEAMP4120 or the PREZONE444
- Dimensions: 80 x 80 x 50 mm
- Weight: 0.2kg

Code: H10508



### MIC-DESK4

Desk microphone- 4 zones - for ZONEAMP4120 or PREZONE444

- 1 front panel XLR microphone input
- 1 rear RJ45 output
- Talk switch on front panel to enable microphone
- Chime switch to launch chime
- Zone selection switch
- Volume setting (Microphone and Chime)
- Lock/unlock switch to block zone selection
- LED level display
- Power by RJ45 cable from the ZONEAMP4120 or the PREZONE444
- Frequency response: 45 Hz - 15 kHz
- T.H.D (1 kHz nominal power): < 0.1%
- Dimensions: 140 x 60 x 205 mm
- Weight: 0.9kg

Code: H10509



**New**

### RJMF10

RJ45 M/F cable 10cm

Code: H10929

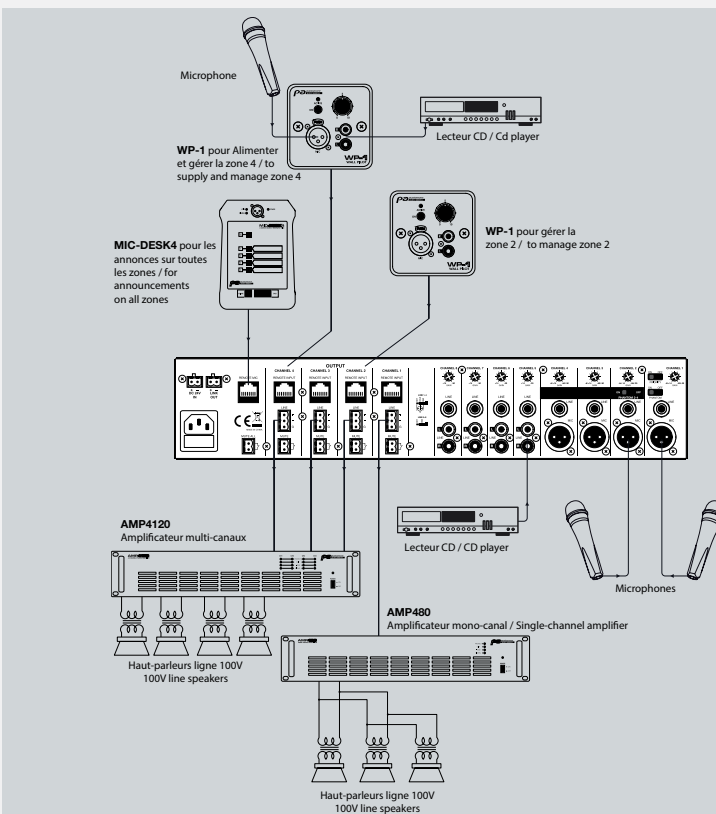

### WP1 AND MIC-DESK4 COMPATIBLE

The WP1 allows you to relocate an input into another room and control the volume of this zone.

The MIC-DESK4 is perfect for public announcements in selected zones.

# 10-channel and 2-zone preamplifier



Resolutely oriented to professional installation, the PREZONE642 mixer/preamplifier provides 6 mono mic/line inputs on XLR or Jack and 4 stereo inputs on RCA or Jack.

Each input can be sent separately to each of the two zones, or to the two simultaneously, in order to offer a maximum of possibilities.

Each zone is equipped with a filtered and volume-adjustable SUB output and an insert for the placement of an additional effect or protection. The mixer is also equipped with a preview section with headphone output for managing each zone.

## PREZONE642

10-channel and 2-zone preamplifier

- 6 Mono Mic/Line input via XLR/jack mono
- Phantom power supply and Talkover on channel 1 and 2
- 4 RCA or Jack stereo input
- Jack 6.35 Priority input
- Zone 1 and 2 mono balanced XLR output
- Jack 6.35 TRS zone insert
- 1 Jack balanced SUB output per zone
- RCA balanced stereo REC output
- 3-way tone and gain control via mic inputs
- Gain control via stereo inputs
- 2-way tone control per zone
- SUB volume control per zone
- Installer-dedicated settings accessible with a screwdriver
- Zone assignment, PFL on each channel strip
- LED Peak and Signal display
- A 8-LED view meter displays the output level for each zone
- Headset output with volume control (zones and PFL)
- Power supply : 230V 50/60 Hz
- Power consumption : 16Watts
- 24V DC with Link Out emergency power supply
- Frequency response :  
- 20 Hz - 20 kHz (+/- 3dB)
- T.H.D (1 kHz nominal power) : < 0,2%
- Equalizer :  
- High : +/-12 dB @ 12,5 kHz  
- Mid : +/-12 dB @ 2,5 kHz  
- Low +/- 12 dB @ 80 Hz
- Dimensions : 295 x 085 x 482 mm
- Mountable in 19" wide racks
- Height : 2 units
- Weight : 5 kg

Code: H9902



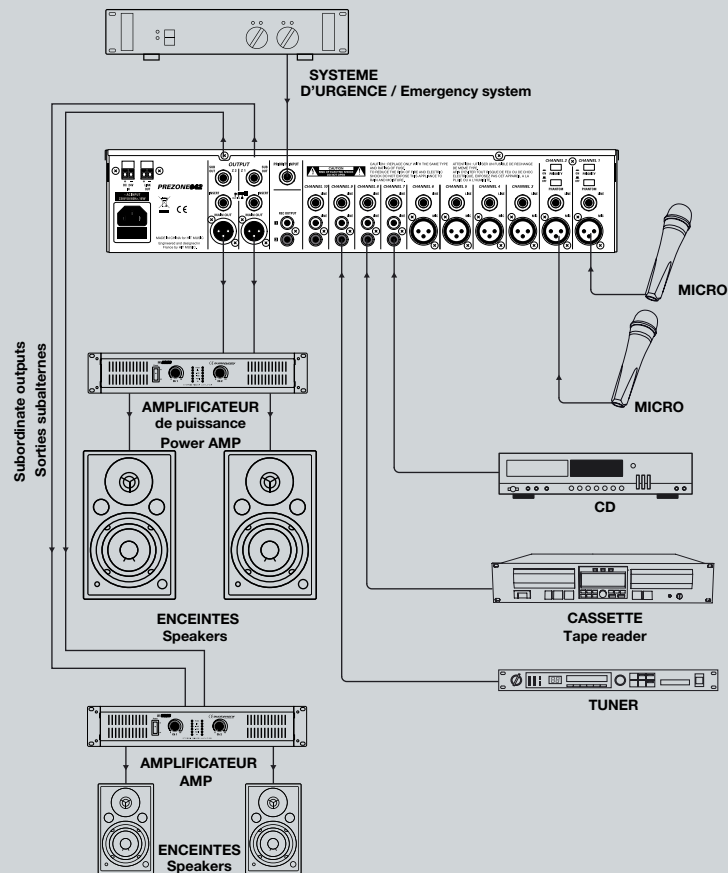

**EACH MIC INPUT FEATURES :**

- A gain control
- A 3-band equalizer
- This settings are made during the installation and can only be changed with a screwdriver

**EACH LINE INPUT FEATURES:**

- A gain control  
(This settings are made during the installation and can only be changed with a screwdriver)



**EACH ZONE HAS ITS OWN :**

- Volume control
- Equalizer
- SUB output settings
- Output level meter

**CONNECT A HEADSET TO BE ABLE TO:**

- Use the PFL switches to monitor the pre-fader signal per zone
- Listen to the pre-fader signal of each channel independently.

# Mixer 1 unit 8 inputs/2 stereo outputs with priority + Remote Mic



**New**

## MX82

1U 8IN 2OUT stereo mixer with priority + Remote Mic

- Rated output Level/impedance : 0 dB / 600 Ohms balanced
- Input sensitivity / Impedance:
- Mic input (CH1-2) - 60 dB~ - 16dB / 20 Ohms balanced
- Line input (CH1-6) - 60 dB~ + 4dB / 20 Ohms balanced
- Frequency Response (-1 dB): 20 Hz - 20 000 Hz
- T.H.D: < 0,1%
- Closstalk: > 70 dB
- Equalization :
- Mic input : High: 12 kHz ± 15 dB / Mid : 2,5 kHz ± 15 dB / Low : 80 Hz ± 15 dB
- Output: High: 10 kHz ± 15 dB / Low : 100 Hz ± 15 dB
- Hum & Noise: >90 dB
- Power source: AC 240V
- Weight: 9 kg
- Dimensions: 482 x 44 x 320 mm

Code: H10926

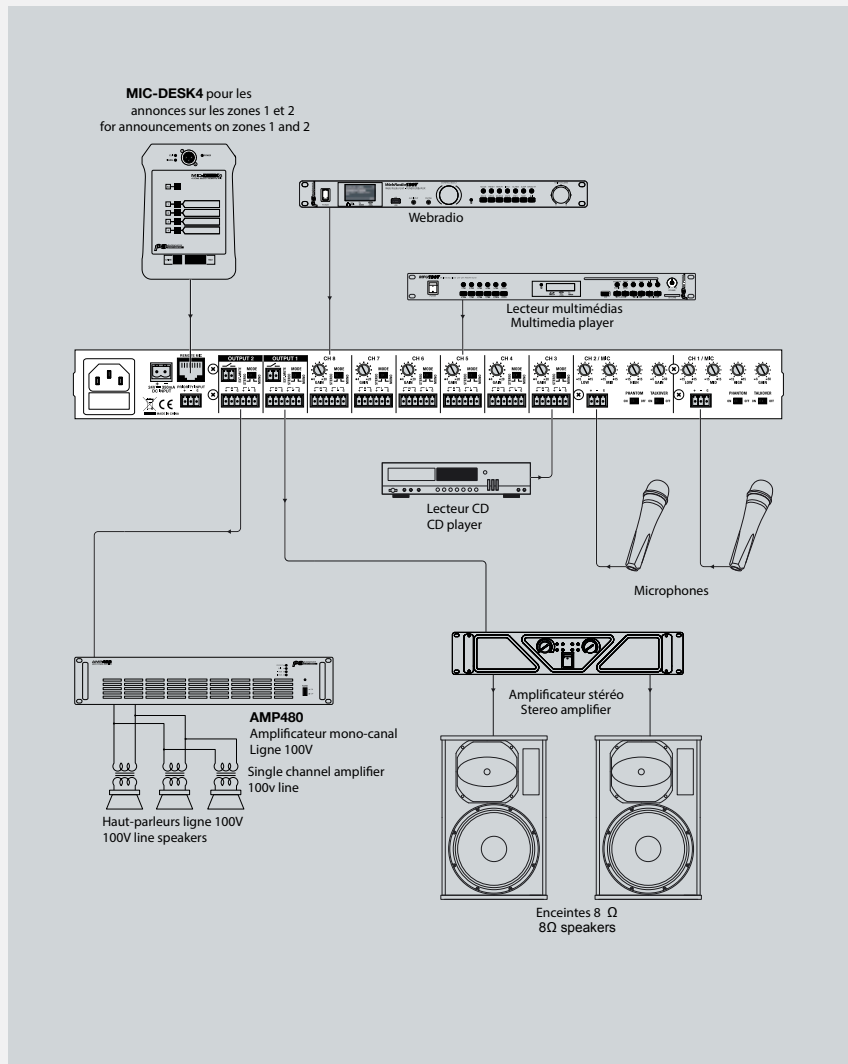



**ASSOCIATED PRODUCT :**



**MIC-DESK4**

Desk microphone - 4 zones - for ZONEAMP4120 or PREZONE444

- 1 front panel XLR microphone input
- 1 rear RJ45 output
- Talk switch on front panel to enable microphone
- Chime switch to launch chime
- Zone selection switch
- Volume setting (Microphone and Chime)
- Lock/unlock switch to block zone selection
- LED level display
- Power by RJ45 cable from the ZONEAMP4120 or the PREZONE444
- Frequency response: 45 Hz - 15 kHz
- T.H.D (1 kHz nominal power): < 0.1%
- Dimensions: 140 x 60 x 205 mm
- Weight: 0.9kg

Code: H10509



**8 INPUTS**

Each input can be routed to your chosen zone or zones. Installer settings are accessible with a screwdriver.

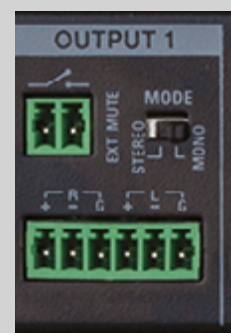

**2 OUTPUTS**

The MX82 has 2 outputs equipped with a 2-band equalizer and independent level adjustment.



# Amplified mixing desk - 8 channels 4x120W outputs



- + 4x120W Built-in amplifier at 100V with 8-channel mixer
- + Each input can be sent to the zone of your choice
- + Compatible with the WP1 wall-controller and MIC-DESK4

## ZONEAMP4120

Amplified mixing desk - 8 channels 4x120W outputs

- 4 Mic/Line inputs on XLR/6.35 Jack (TRS)
- 4 stereo inputs on RCA or 6.35 Mono Jack
- 4 link out outputs per zone on Phoenix plug
- 4 120W at 100V outputs on Phoenix plug
- Microphone priority on input 1
- Phantom power on inputs 1 to 4
- Gain and tone control (3 bands) on channels 1 to 4
- Gain control on all inputs
- Tone control (2 bands) per zone
- 5 RJ45 connectors to connect 1x WP-1 per zone and to connect 1x MIC-DESK4
- General Mute key
- Zone allocation 1 to 4 on each input
- Signal / Peak display on each input
- 5 LEDVU meters per zone
- AFL / PFL front panel HP monitoring
- Power supply: 230V 50/60 Hz
- Frequency response: 20 Hz - 20 kHz
- Dimensions: 320 x 088 x 482 mm
- 19-inch rackable, Height: 2 units
- Weight: 9 kg

Code: H10513



### 8 INPUTS

Each input can be sent to one or several zones of your choices.

Technicians settings can be accessed with a screwdriver.



### 4 OUTPUTS

The ZONEAMP4120 features a monitoring loudspeaker to check the signal sent by each output.



### WP-1

Wall-mounted controller for ZONEAMP4120 or PREZONE444

- 1 front panel XLR microphone input
- 1 front panel RCA line input
- 1 back panel RJ45 connection
- Front panel volume control
- ON/OFF Switch
- Source display shown by LED
- DC15V power by RJ45 cable from the ZONEAMP4120 or the PREZONE444
- Dimensions: 80 x 80 x 50 mm
- Weight: 0.2kg

Code: H10508



### MIC-DESK4

Desk microphone- 4 zones - for ZONEAMP4120 or PREZONE444

- 1 front panel XLR microphone input
- 1 rear RJ45 output
- Talk switch on front panel to enable microphone
- Chime switch to launch chime
- Zone selection switch
- Volume setting (Microphone and Chime)
- Lock/unlock switch to block zone selection
- LED level display
- Power by RJ45 cable from the ZONEAMP4120 or the PREZONE444
- Frequency response: 45 Hz - 15 kHz
- T.H.D (1 kHz nominal power): < 0.1%
- Dimensions: 140 x 60 x 205 mm
- Weight: 0.9kg

Code: H10509



**New**

### RJMF10

RJ45 M/F cable 10cm

Code: H10929

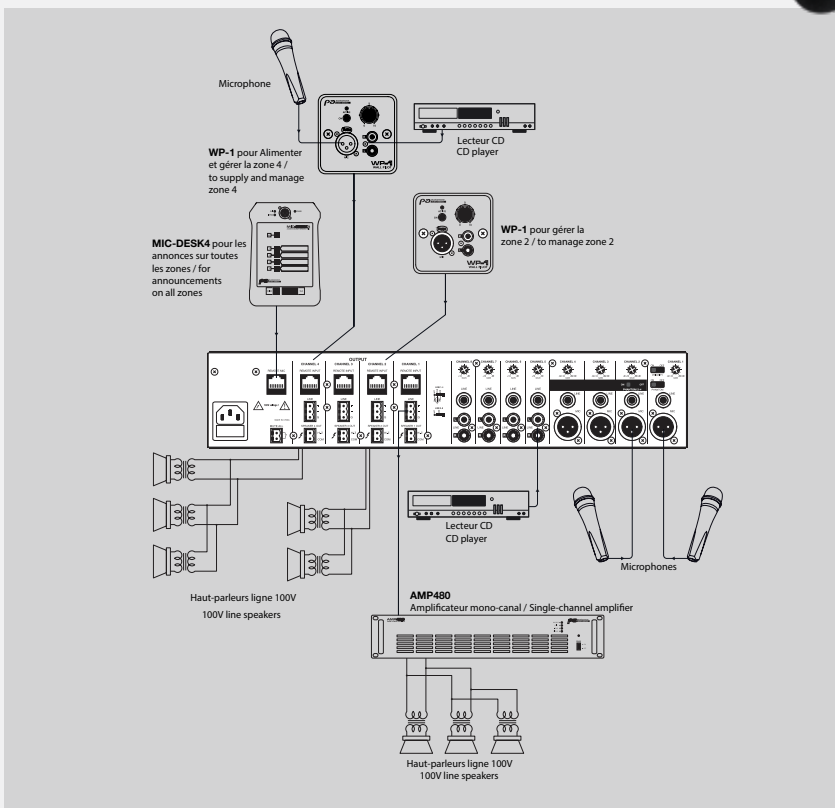

### WP1 AND MIC-DESK4 COMPATIBLE

The WP1 allows you to relocate an input into another room and control the volume of this zone.

The MIC-DESK4 is perfect for public announcements in selected zones.

# Multi-zone combined mixer amplifier line 100V combo 5 zones 6 inputs - 240W

- + All-in-one system with multimedia option
- + 6-input mixer
- + 5 Switchable zones
- + 7-band graphic equaliser
- + Paging and chime control
- + 19-inch rackable
- + Removable brackets



## COMBO240

Multi-zone combined mixer amplifier line 100V combo 5 zones 6 inputs - 240W

- All-in-one 240W system with multimedia option
- 6-input mixer
- 5 independent simultaneous zones
- 7-band graphic equalizer
- Paging, siren and chime control
- Priority mode and Phantom power on channels 1 and 2
- 5-pin DIN input microphone 1
- XLR line or microphone input on channels 2 to 5
- RCA input on channel 6
- Paging input on Phoenix plug
- AMP IN and PRE-AMP OUT connections
- LINK IN and LINK OUT connections
- 100V / 8 to 4 Ohms outputs on the terminal block
- Dimensions: 420 x 320 x 88 mm
- 19-inch rackable
- Weight: 10.8 kg

Code: H9751



## MOD1

USB/SD reader and Tuner AM/FM receiver for COMBO240

- Tuner receiver: AM / FM
- Autoscans, Manual scan
- FM frequencies: 87.5 MHz - 108 MHz
- AM frequencies: 522 kHz - 1620 kHz
- USB reader: mp3 files
- Functions: read, search, programming
- Recognition of more than 2000 files and 200 folders.
- Equalisation: Classic / Pop / Jazz / Rock with the LOUD function
- Technical characteristics:
- Signal-to-noise ratio: Less than 70 dB
- Frequency response: 20 Hz - 20 kHz
- THD: Less than 0.1%
- Maximum consumption: 500 mA

Code: H9752



## MIC-DESK

Push-to-talk desk microphone

- Push-to-talk button
- Frequency response : 40 Hz-16 kHz
- Sensitivity : -43 dB
- Impedance : 200 ?
- Supplied with a 3-meter long cord
- Dimensions : 430 x 200 x 75 mm
- Weight : 1.05 kg

Code: H9748

## ASSOCIATED PRODUCT :

Supplied with a COMBO240 5-pin cable to remotely activate the chime.

Jack cable without chime activation for the other amplifiers (COMBO60, COMBO130, PREZONE642).





**MOD1**

This module is a real multimedia player allowing you to play audio files from a SD card, USB key or hard disk and AM/ FM tuner.

# Amplifier, mixer and tuner within the same housing



- + All-in-one system
- + 5-channel mixer
- + Activate the chime via a pushbutton
- + Mountable in 19" wide racks
- + 70 V/100 V or low impedance amplified output
- + 1 front mic input

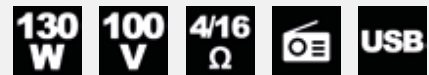

## COMBO130

Mixer/Amplifier/Multimedia player

- 130W all-in-one system
- 5-input mixer:
- 3-way microphone - Aux1/MP3/TUNER -Aux2
- Low and high settings
- Mp3 and Tuner controls
- Chime activation
- Output levelVU meter
- 6.35 input jack for microphones 1 and 2
- RCA input for AUX1 and AUX2
- OUT output on RCA
- Connections for FM and AM antennas
- 100V / 16 to 4 Ohms outputs on the terminal block
- Tuner receiver: AM / FM
- Autoscan, Manual scan
- FM frequencies: 87.5 MHz - 108 MHz
- AM frequencies: 522 kHz - 1620 kHz
- USB reader: mp3 files
- Functions: read, search, programming time setting
- Power: 220 V 50-60 Hz
- Consumption: 175 W
- Dimensions: 483 x 89 x 366 mm
- Net weight: 11.36 kg

Code: H9750

### ASSOCIATED PRODUCT :



#### MIC-DESK

Push-to-talk desk microphone

Code: H9748

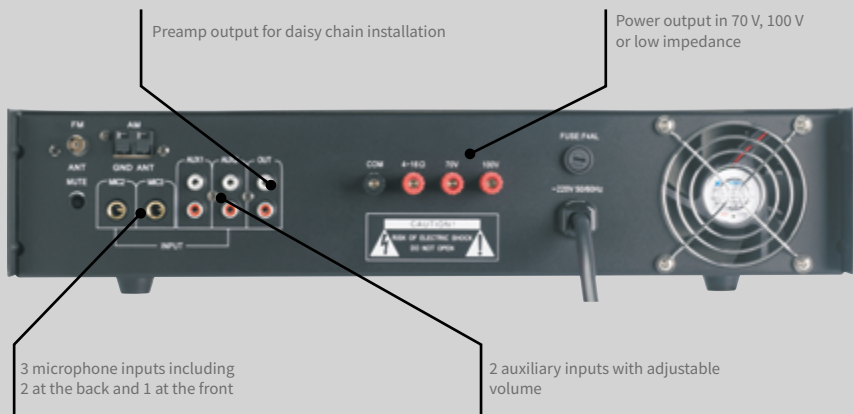

# Mixer/Amplifier/Multimedia player. All-in-one, ultra compact and super efficient

- + Compact all-in-one system
- + Built-in USB player and Tuner
- + 2 Line inputs and one Mic input
- + Music on hold and telepaging functions
- + Safety priority output
- + 3-band equalizer

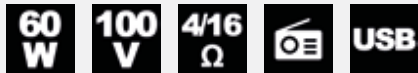

## COMBO60

Mixer/Amplifier/Multimedia player

- 60W compact all-in-one system
  - 3-input mixer:
    - 2-way microphone - Aux1/MP3/TUNER
  - Low, mid and high settings
  - Mp3 and Tuner player controls
  - Output levelVU meter
  - 6.35 input jack for microphones
  - AUX input and CD on RCA
  - Waiting music input on Phoenix plug
  - Paging input on Phoenix plug
  - Connections for FM and AM antennas
  - 100V / 16 / 8 / 4 Ohms outputs on the terminal block
- Tuner receiver: AM / FM
  - Autoscan, Manual scan
  - FM frequencies: 87.5 MHz - 108 MHz
  - AM frequencies: 522 kHz - 1620 kHz
  - USB reader: mp3 files
  - Functions: read, search, programming time setting
  - Power: 220 V 50-60 Hz
  - Consumption: 175 W
  - Dimensions: 90 x 270 x 260 mm
  - Net weight: 5 kg
- Code: H9749

### ASSOCIATED PRODUCT :



#### MIC-DESK

Push-to-talk desk microphone

Code: H9748

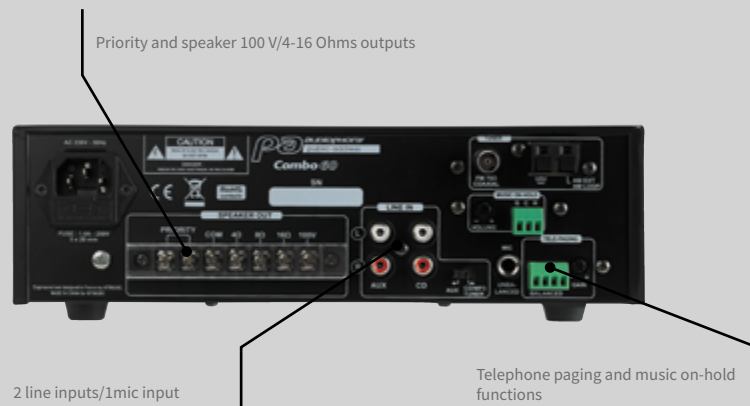

# 4 channels Public Address amplifier



**100 V** **4X120 W**

## AMP4120

4 channels Public Address amplifier - 4 x 120W

- 4 Mono inputs via Phoenix plugs
- 4 Speaker outputs at 100V via Phoenix plug
- 4 Line-level link output via Phoenix plug
- Volume settings for each channel
- Flat/HPF Switch for each channel
- Output display for each channel via 4-LEDVU meter
- Screwdriver required to access technician-level settings
- Power supply: 230V 50/60 Hz
- Frequency response: 50 Hz - 15 kHz
- T.H.D (1 kHz nominal power): 0.1%
- Dimensions: 380 x 088 x 482 mm
- 19" mount-rackable
- Height: 2 units
- Weight: 7.2kg

Code: H10511



**100 V** **4X240 W**

## AMP4240

4 channels Public Address amplifier - 4x 240W

- 4 Mono inputs via Phoenix plugs
- 4 Speaker outputs at 100V via Phoenix plug
- 4 Line-level link output via Phoenix plug
- Volume settings for each channel
- Flat/HPF Switch for each channel
- Output display for each channel via 4-LEDVU meter
- Screwdriver required to access technician-level settings
- Power supply: 230V 50/60 Hz
- Frequency response: 50 Hz - 15 kHz
- T.H.D (1 kHz nominal power): 0.1%
- Dimensions: 380 x 088 x 482 mm
- 19" mount-rackable
- Height: 2 units
- Weight: 7.5kg

Code: H10506

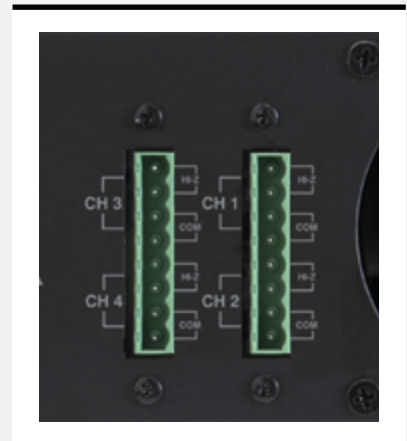



# Public Address amplifier - 1 x 480W

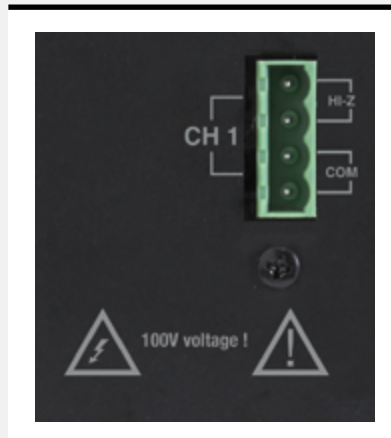

## AMP480

Public Address amplifier - 1 x 480W

- 1 mono input via Phoenix plug
- 1 Speaker output at 100V via Phoenix plug
- 1 line-level link output via Phoenix plug
- Channel volume settings
- Flat/HPF channel switch
- Output volume display via 4-LED viewmeter
- Screwdriver required to access technician-level settings
- Power supply: 230V 50/60 Hz
- Frequency response: 50 Hz - 15 kHz
- T.H.D (1 kHz nominal power) : 0.1%
- Dimensions: 380 x 088 x 482 mm
- 19" mount-rackable
- Height: 2 units
- Weight : 6.6kg

Code: H10512



# Amplifiers

## 1 x 120W & 1 x 240W



### AMP120

120W Professional amplifier for 100v installations

- RMS power: 120W
- Output levels / Impedance:
  - 100V (83 Ohms)
  - 70V (42 Ohms)
  - 4 Ohms (21.9V)
- Balanced XLR input/output
- Power output on Phoenix plug
- Frequency response: 70 Hz – 18 KHz
- T.H.D (1 KHz): <1%
- 400 Hz High-pass filter
- Power supply: 230V 50/60 Hz
- DC24V (safe power)
- Dimensions: 482 x 88 x 330 mm
- 19-inch rackable, Height: 2 units
- Net weight: 11.6 Kg

Code: H9903



### AMP240

240W Professional amplifier for 100v installations

- RMS power: 240W
- Output levels / Impedance:
  - 100V (42 Ohms)
  - 70V (21 Ohms)
  - 4 Ohms (31V)
- Balanced XLR input/output
- Power output on Phoenix plug
- Frequency response: 70 Hz – 18 KHz
- T.H.D (1 KHz): <1%
- 400 Hz High-pass filter
- Power supply: 230V 50/60 Hz
- DC24V (safe power)
- Dimensions: 482 x 88 x 330 mm
- 19-inch rackable, Height: 2 units
- Net weight: 13.8 Kg

Code: H9904





**REG60**

100V power regulator

- Power output : 60W
- Power supply: 100V
- 24 Priority input for alarm messages
- Settings: OFF/-17DB/-11DB/-4.5DB/0DB
- Frequency response: 20Hz - 20kHz

- Materials:
- White ABS housing

- Connectors: 6-pin connector (IN+ IN- / OUT+ OUT- / 0V 24V)
- Dimensions: 86 x 86 x 70 mm
- Weight: 0.250 kg

Code: H9753



**REG-BOX**

Housing box for 1 REG60 wall-mounted controller

Code: H9754



**TFS20**

Transformer 20W Input 2.5/5/10/20w in 100v out 8Ohms

Code: H10975



**TFS60**

60W Transformer Input 7.5/15/30/60w in 100v out 8Ohms

Code: H10976

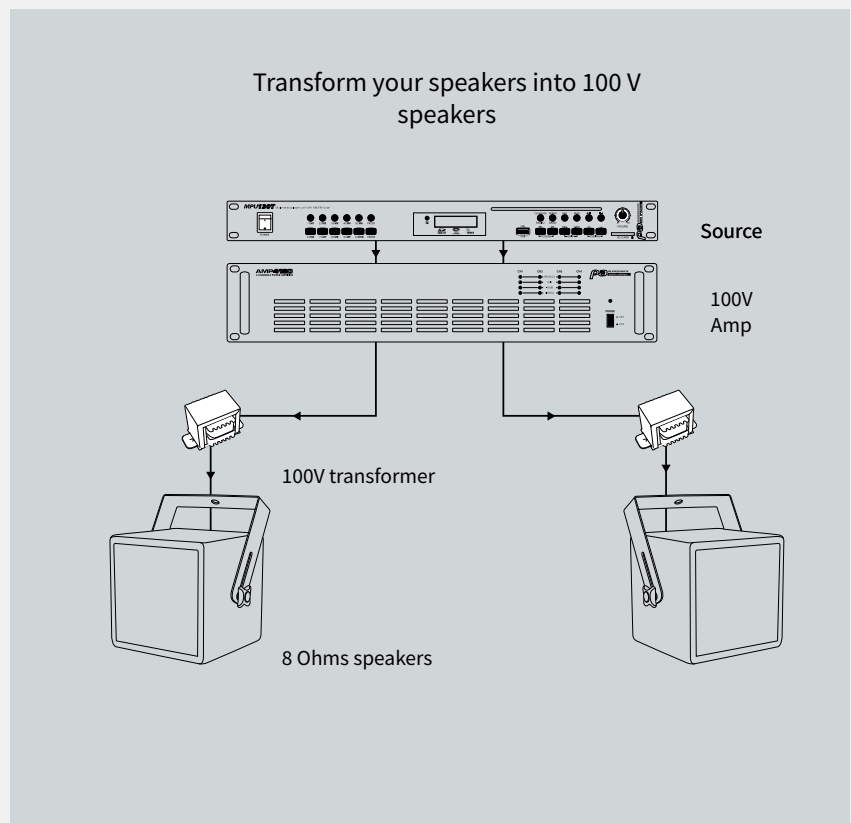

# 2x20W wall-mounted amplifier

SD/BT/AUX/DLNA/Airplay & App with touch screen



## WALLAMPPAD

2x20W wall-mounted amplifier with SD/BT/AUX/DLNA/Airplay & App with touch screen

- Power : 2X20W
- Impedance: 8 Ohms
- Power supplies: 240V
- Frequency response: 20 - 20 000 Hz
- Aux output for an external amplifier
- Port: SD/ RJ45 / AUX
- Sources: Bluetooth® / DLNA / Airplay /WIFI /Webradio / Network music / Application / Aux in
- Dimensions: 172 x 86 x 45 mm

Code: H10932

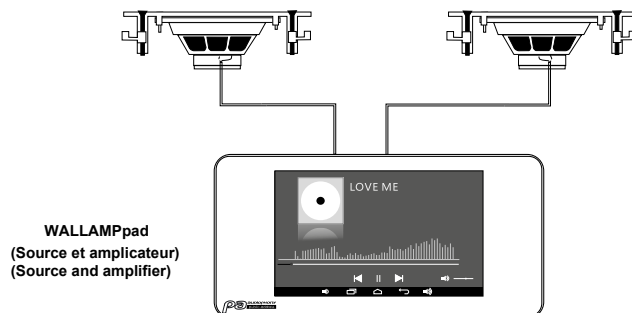





New



# 2x10W wall amplifier

SD/BT/Radio/AUX touch screen



## WALLAMPTOUCH

2x10W wall amplifier with SD/BT/Radio/AUX touch screen

- Power ratings: 2x10W
- Impedance: 8 Ohms
- Power supply: 240V
- Frequency response: 20 - 20 000 kHz
- Output: Line output for external amplifier
- Port: SD, USB, AUX
- Audio format: MP3,WMA,WAV, AAC, FLAC
- Infrared remote control
- Bluetooth: 4.0
- Dimensions: 86 x 86 x 86 x 38 mm

Code: H10931

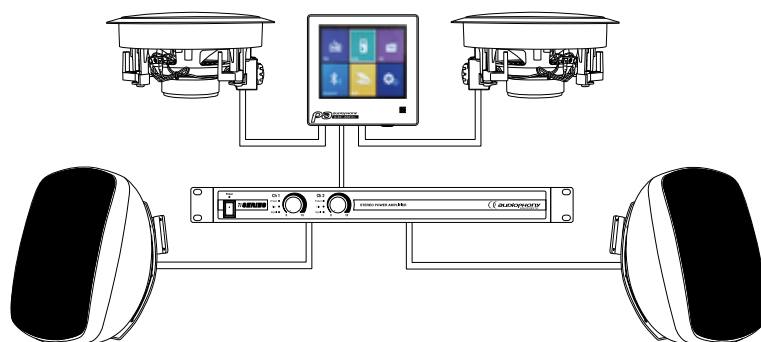



# Wall amplifier 2x10W

SD/BT/Radio/AUX with line output



## WALLAMPEDIA

Wall amplifier 2x10W SD/BT/Radio/AUX with line output

- Power outputs: 2x10W
- Impedance: 8 Ohms
- Power supply: 240V
- Signal-to-noise ratio: >81 dB
- Output: Line output for external amplifier
- Memory card capacity: 128 MB - 32GB
- Audio format: MP3,WMA,WAV, AAC, FLAC
- Bluetooth: 2.1+EDR
- Dimensions: 86 x 86 x 86 x 38 mm

Code: H10930

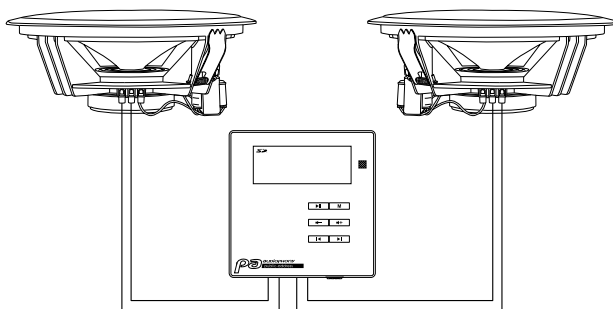





New



# 2x10W wall amplifier

SD/BT/Radio/AUX touch screen

NO  
LOGO  
ON PRODUCT

 **Bluetooth™**



# WA



## WALLKIT

WALLAMPmedia + ceiling systems

- Wall amplifier set
- WALLAMPmedia 2 x 10W with 2x 2-way ceiling speakers
- Power supply: 240V
- Impedance: 8 Ohms
- Components: 6.5" + 0.75"
- Sensitivity. (1W/1m): 93 dB, +/-3dB
- Frequency response: 90-18 000 Hz
- Construction: Black ABS body and white magnetic metal grid
- Hook: 2 spring legs
- Dimensions: 190 mm (diameter) x 80 mm
- Weight: 1 Kg

Code: H10964

# ALLKIT



New



# 6.5" active ceiling speaker

## Kit of two loudspeakers

The CHP6A-Bset system is recommended for rooms of 50 m<sup>2</sup> or less.



# CH

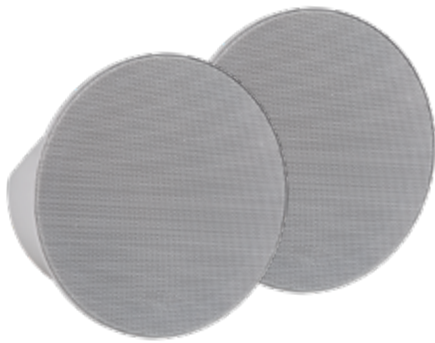

### CHP6A-BSET

2x 6.5" active ceiling speaker 2 x 10W BT 4.0

- RMS power output : 2x 10W
- Impedance: 8 Ohms
- Components : 6.5"
- Sensitivity (1W/1m): 90 dB, +/-2dB
- Frequency response : 110-15 000 Hz
- Material :White plastic enclosure
- Holding : 2 string grip
- Connectors: Euro block
- Bluetooth: 4.0
- Dimensions : 190 mm (diam) x 105 mm
- Weight : 1 Kg
- Set of two ceiling speakers, one of which is active (with Bluetooth® receiver) and powers the other (passive)

Code: H10933

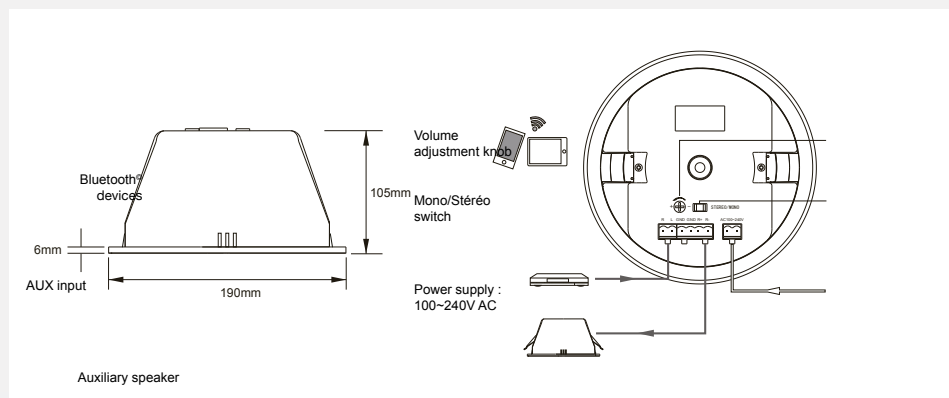



# IP6A

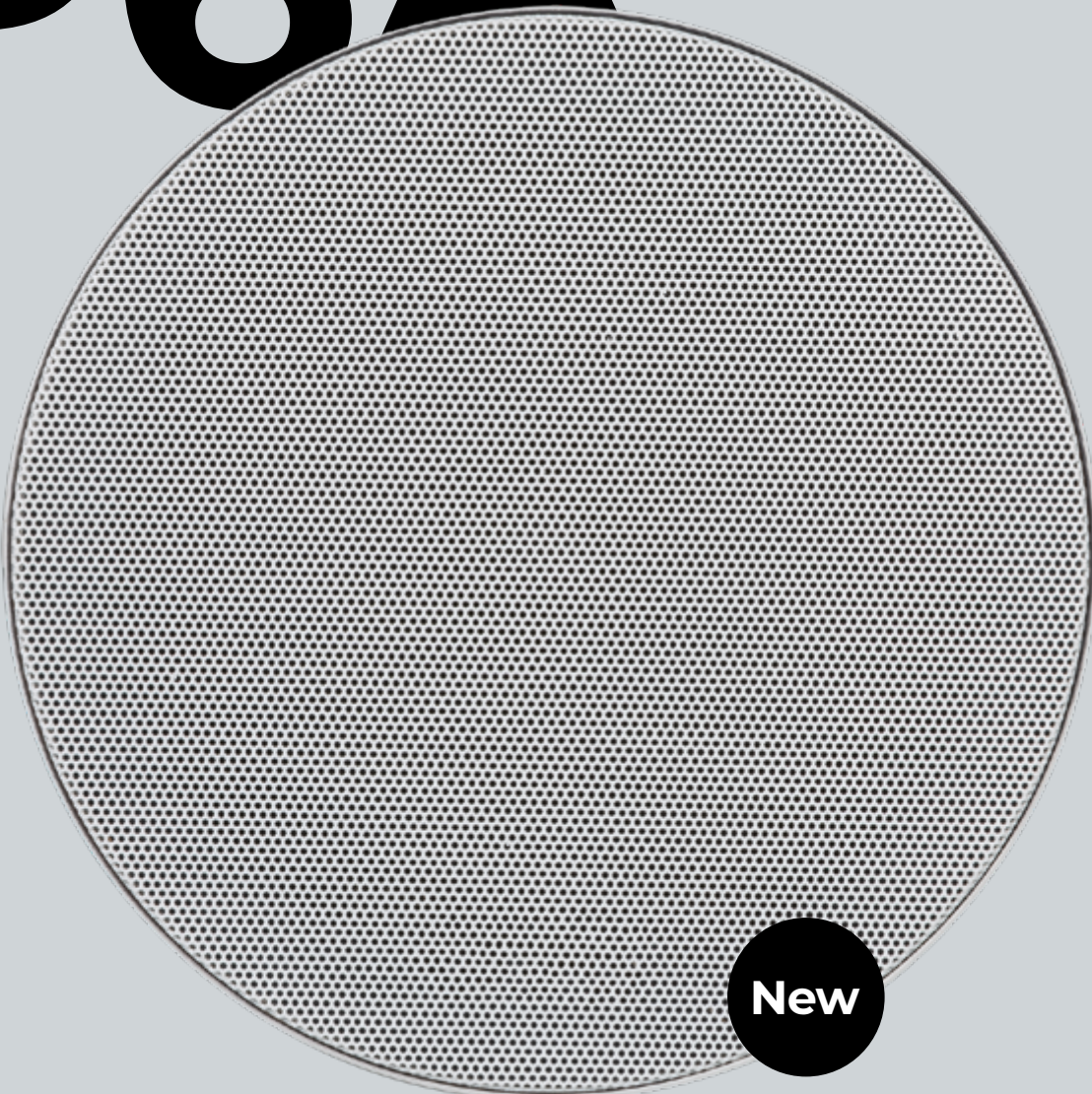

New



# Discreet speaker IP66

Discrete speaker IP66

NO  
LOGO  
ON PRODUCT



# KIO



## KIOSK45

Discrete speaker with IP66 45W 6.5" 100V terminal

- Power ratings: 23 / 45W
- Power supply: 100V
- Components: 1 x 6.5" + 1 x 3" + 1 x 3
- Sensitivity (1W/1m): 86 dB, +/-2dB
- Frequency response: 80-10 000 Hz
- Construction: Aluminium (resistant to major damage)
- Hook: Floor mounting plate
- Waterproofing level: IP66
- Dimensions: 240 mm (diameter) x 440 mm
- Weight: 6 Kg

Code: H10966

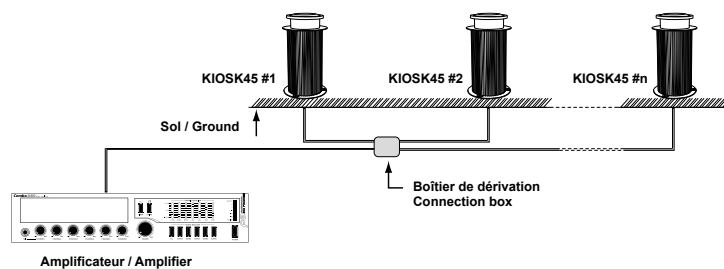
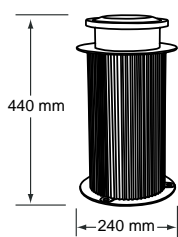

# OSK 45



**New**

# Discreet rock speaker IP66

Rock style outdoor speaker for 100V amplifiers.

NO  
LOGO  
ON PRODUCT



# STO



## STONE45

Discreet rock speaker IP66 45W 6.5" 100V

- Power ratings: 23 / 45W
- Power supply: 100V
- Components: 6.5" + 1" + 1
- Sensitivity (1W/1m): 88 dB, +/-3dB
- Frequency response: 80-16 000 Hz
- Construction: high quality, weatherproof, rock-shaped resin housing
- Hook: Floor mounting plate
- Waterproofing level: IP66
- Dimensions: 250 x 360 x 420 mm
- Weight: 7 Kg

Code: H10967

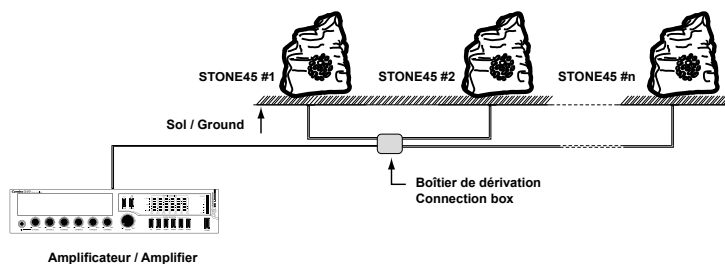
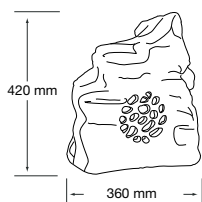



# ONE 45



**New**

# 50W Sound projector

Its high power and large housing can cover a vast area  
Perfect vocal and music reproduction  
Durable and weatherproof

NO  
LOGO  
ON PRODUCT



# PH



## PHP650

Sound projector 50W 70/100V / 8 Ohms IP66

- Surface mount loudspeaker
- RMS power output : 50W
- Power outputs : 2.6W, 4.5W, 9W, 12.5W, 25W or 50W
- 100V
- Loudspeaker : 165 mm (6.5") et 1" compression
- Frequency response : 90 Hz – 20 kHz
- Sensitivity >99 +/-3 dB
- Material : ABS enclosure
- Fixation : Adjustable holding bracket
- Internal connector: waterproof cable gland
- IP level: IP55 (dust and water protected)
- Dimensions : 363 x 253 x 310 mm

Code: H10211

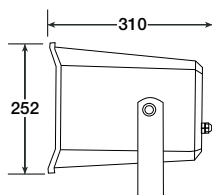
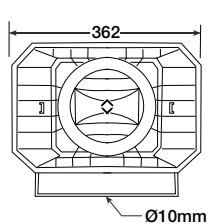

# IP 650

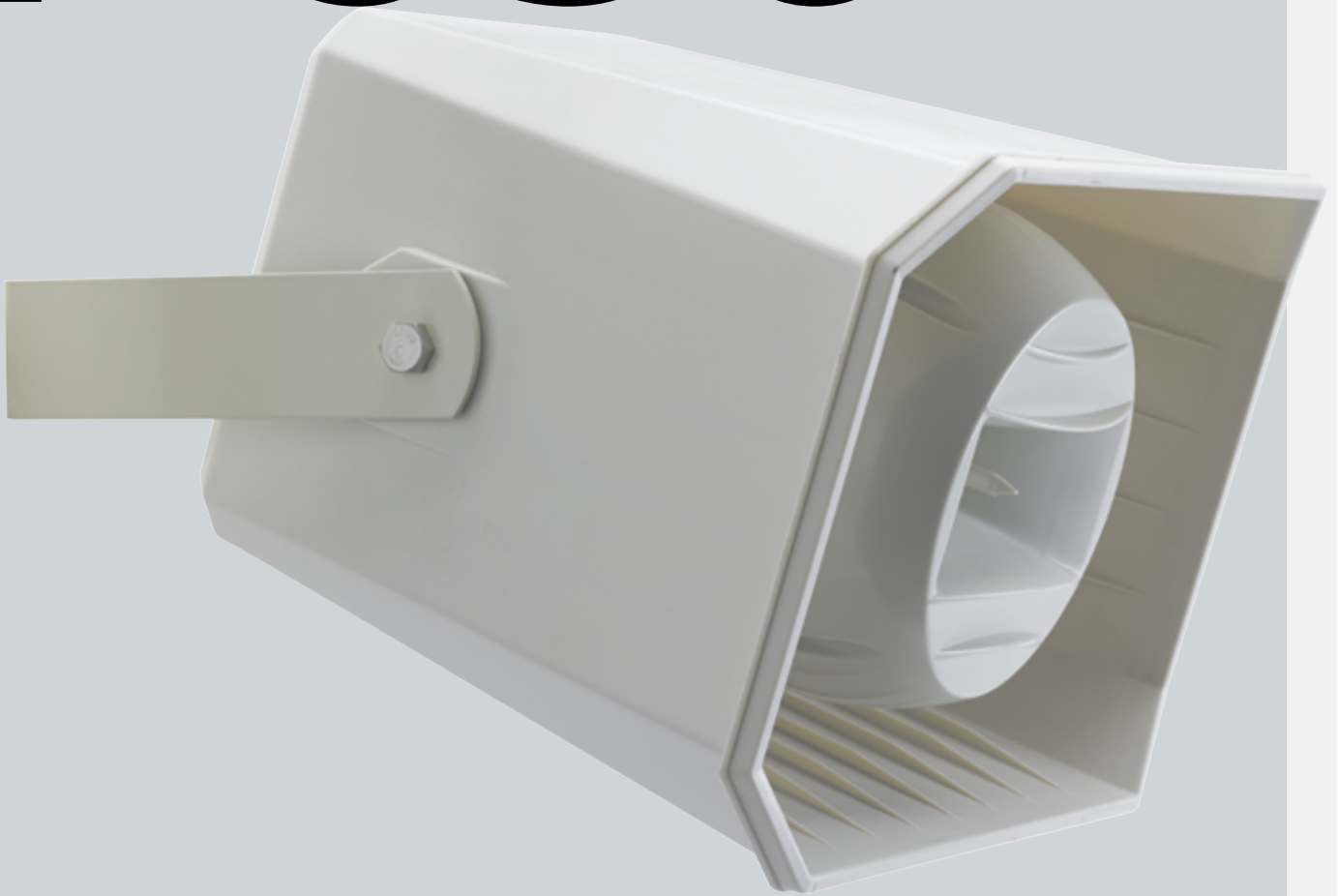

# Surface mount loudspeaker

# PH

When music takes to the streets.  
The PHP510 sound projector is as good indoor as outdoor.  
It features an integral aluminium housing and can be  
installed and operated even in poor weather.  
It's large housing makes it perfect for vast open spaces.



## PHP510

Sound projector IP55 5" 70/100V aluminium 3/6/10W

- Surface mount loudspeaker
- RMS power output : 10 W
- Max power output : 18 W
- Power outputs : 2,5 W, 5 W or 10 W
- 70/100 V
- Loudspeaker : 130 mm (5")
- Frequency response : 150 Hz – 14 kHz
- Sensitivity: >90 dB
- Material :White aluminium enclosure, white steel grille
- Fixation: Adjustable holding bracket
- Internal connector: waterproof cable gland
- IP level: IP55 (dust and water protected)
- Dimensions : 138 x 205 mm
- Weight : 2.1 kg

Code: H9759

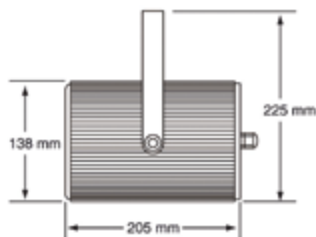



# P510



# Pendant loudspeaker

When sound rises above.

The SHP and PHP sound projectors are as good indoor as outdoor.

They feature an integral aluminium housing and can be installed and operated even in poor weather.

Their large housing make them perfect for vast open spaces

NO  
LOGO  
ON PRODUCT



# SH



## SHP510

IP55 suspended speaker 5" 70/100V alu 2,5/10W

- Pendant loudspeaker
- RMS power output : 10 W
- Max power output : 18 W
- Power outputs : 2.5 W, 5 W ou 10 W
- 70/100 V
- Loudspeaker : 130 mm (5")
- Frequency response : 150 Hz – 15 kHz
- Sensitivity: >90 dB
- Material :White aluminium enclosure, white steel grille
- Fixation : Safety-rope inside the cable sheath
- Internal connector: waterproof cable gland
- IP level: IP55 (dust and water protected)
- Dimensions (Ø x D) : 138 x 205 mm
- Weight : 2.2 kg

Code: H9758

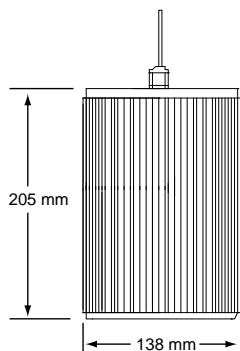

# P510

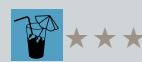
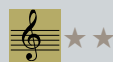

# 360° diffusion pendant speaker

360°diffusion pendant speaker for 100V amplifiers.  
Delivered with slung cable.

NO  
LOGO  
ON PRODUCT

# SH



## SHP820W

2-way suspended speaker 8" diff. 360°-100V 5 to 20W

- Power outputs : 5 / 10 / 20W
- Voltage : 100V
- Components : 8" + 1"
- Sensitivity (1W/1m): 88 dB, +/-3dB
- Frequency response : 130-15 000 Hz
- Material :White plastic enclosure
- Holding : 5 m slung cable
- Connectors : Cable on gland
- Dimensions : 254 mm (diam)
- Weight : 2,2 kg

Code: H10925

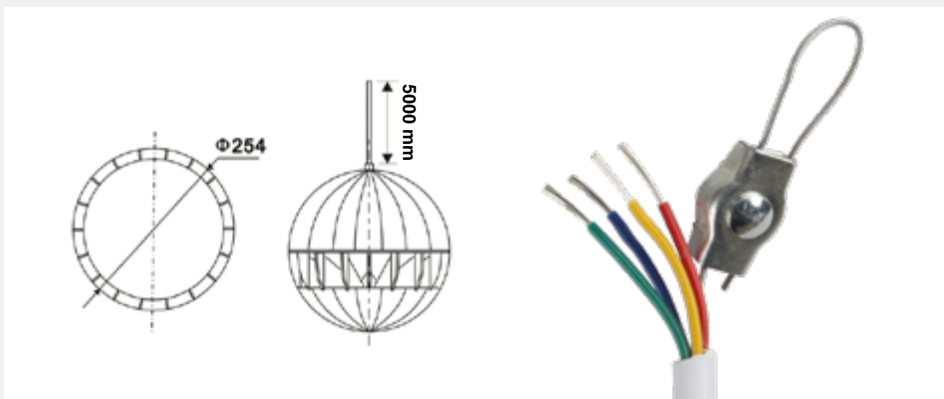



# P820w



# HiFi Outdoor Speaker 100V



## JAVA315B

Tropical speaker 100V 7.5/15W 16 Ohms

- Power outputs : 7,5 / 15W
- Voltage : 100V 16 Ohms
- Components : 3" + 1"
- Sensitivity (1W/1m): 90 dB, +/-3dB
- Frequency response : 90 - 20 000 Hz
- Material : Plastic enclosure and aluminium grille
- Holding :Wallmount bracket
- Connectors :Waterproof cable on gland IP55
- Power rotary knob : 15W 16Ω // 7,5 / 15W 100V
- Dimensions : 112x 158 x 160 (H) mm
- Weight : 0,9 Kg

Code: H10921



## JAVA315W

Tropical speaker 100V 7.5/15W 16 Ohms

- Power outputs : 7,5 / 15W
- Voltage : 100V 16 Ohms
- Components : 3" + 1"
- Sensitivity (1W/1m): 90 dB, +/-3dB
- Frequency response : 90 - 20 000 Hz
- Material : Plastic enclosure and aluminium grille
- Holding :Wallmount bracket
- Connectors :Waterproof cable on gland IP55
- Power rotary knob : 15W 16Ω // 7,5 / 15W 100V
- Dimensions : 112x 158 x 160 (H) mm
- Weight : 0,9 Kg

Code: H10922

- + Use it indoor or outdoor
- + Elegant, refined black or white housing
- + Very discreet holding system, can be vertically or horizontally oriented
- + Requires a low-impedance or a 100V line

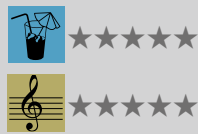

**HiFi**



**NO LOGO  
ON PRODUCT**

**100  
V**

**IP  
55**

**16Ω**



**JAVA530B**

Tropical speaker 100V 3 to 30W 16 Ohms

- Power outputs : 15 / 30W
- Voltage : 100V 16 Ohms
- Components : 5" + 1"
- Sensitivity (1W/1m): 88 dB, +/-3dB
- Frequency response : 60 - 20 000 Hz
- Material : Plastic enclosure and aluminium grille
- Holding : Wallmount bracket
- Connectors : Waterproof cable on gland IP55
- Power rotary knob : 30W 16Ω // 15 / 30W 100V
- Dimensions : 178x 236 x 255 (H) mm
- Weight : 2,38 Kg

Code: H10923



**JAVA530W**

Tropical speaker 100V 3 to 30W 16 Ohms

- Power outputs : 15 / 30W
- Voltage : 100V 16 Ohms
- Components : 5" + 1"
- Sensitivity (1W/1m): 88 dB, +/-3dB
- Frequency response : 60 - 20 000 Hz
- Material : Plastic enclosure and aluminium grille
- Holding : Wallmount bracket
- Connectors : Waterproof cable on gland IP55
- Power rotary knob : 30W 16Ω // 15 / 30W 100V
- Dimensions : 178x 236 x 255 (H) mm
- Weight : 2,38 Kg

Code: H10924

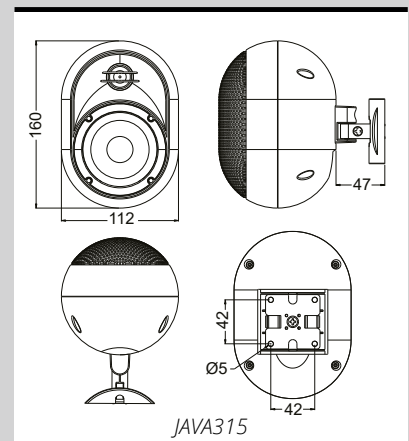
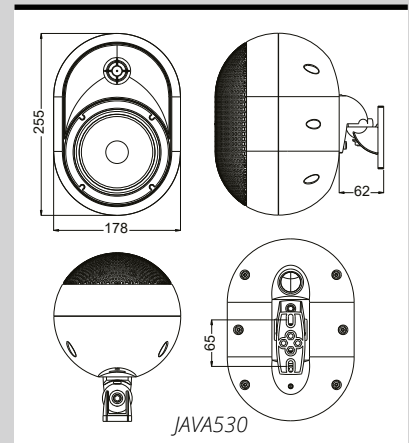

## HiFi Tropical Speaker 100V



### A PERFECT SOUND QUALITY EVERYWHERE

Should it be indoor or outdoor, a background music is always welcome to work, party, or simply be in a good mood. That is why we have a very vast speakers selection fitting your every need. Sound quality, design, installation ...

Each project has its own criterias, and we have the speakers you need for it.

### HIFI QUALITY

The BORNE660 produces an incredible, high-quality sound output even at full volume. It was designed for music lovers. It is weatherproof and can be operated in wet locations.

### OUR ADVICE

To optimise your BORNE660 speakers, we recommend to combine itwith the class D Ti300 Audiophony® amplifier.





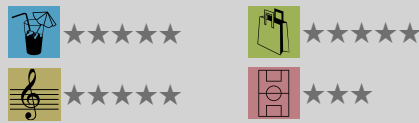

**HiFi**



**NO LOGO  
ON PRODUCT**

**100  
V**

**60  
W**

**8Ω**



**BORNEO660B**

Tropical speaker 60W 8 Ohms - 70-100V

- 2-way speaker
- RMS power output: 60 W
- Max power output : 200 W
- Available power outputs : 60 W/20 W/15 W/10 W/5 W
- 8 Ohms/100 V
- Tweeter : 25 mm (1")
- Boomer : 165 mm (6.5")
- Frequency response : 45 Hz – 20 kHz
- Sensitivity >89 dB
- External dimensions (diameter and depth) : 340 x 220 x 200 mm
- Net weight : 3.8 kg

Code: H9920



**BORNEO660W**

Tropical speaker 60W 8 Ohms - 70-100V

- 2-way speaker
- RMS power output: 60 W
- Max power output : 200 W
- Available power outputs : 60 W/20 W/15 W/10 W/5 W
- 8 Ohms/100 V
- Tweeter : 25 mm (1")
- Boomer : 165 mm (6.5")
- Frequency response : 45 Hz – 20 kHz
- Sensitivity >89 dB
- External dimensions (diameter and depth) : 340 x 220 x 200 mm
- Net weight : 3.8 kg

Code: H9911

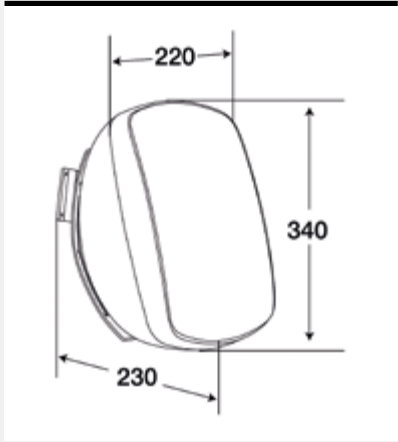

## EHP660IP HiFi Outdoor Speaker 100V



### HiFi or 100V

The EHP660 speakers can be used with a low impedance or a 100V line.

They are absolutely perfect to broadcast voice or music, and fit any kind of installation: shops, conference rooms, waiting rooms, places of worship...

The volume controller allows you to adjust it to your needs. permet de limiter le volume de la diffusion en fonction des besoins.

- + Use it indoor or outdoor
- + Elegant, refined black or white housing
- + Very discreet holding system, can be vertically or horizontally oriented
- + Requires a low-impedance or a 100V line



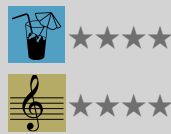
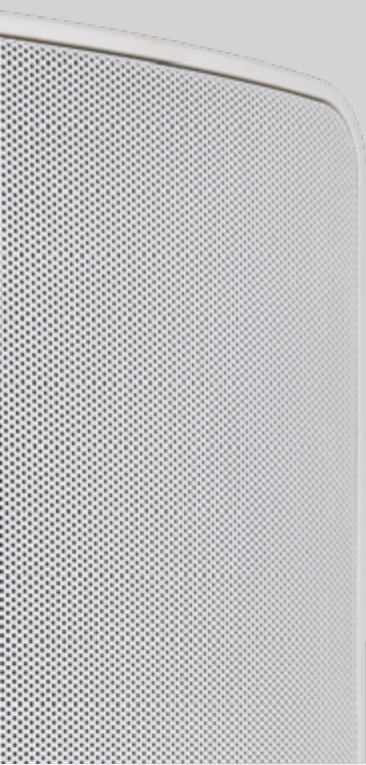

**HiFi**



**NO LOGO  
ON PRODUCT**

**100  
V**

**IP  
55**

**60  
W**

**8Ω**



**x2**

**New**

**EHP660IPB**

Tropical speaker 6" 100V 7.5 to 60W 8 Ohms

- Power outputs : 7,5 / 15 / 30 / 60W
- Voltage : 100V 8 Ohms
- Components : 6,5" + 1"
- Sensitivity (1W/1m): 90 dB, +/-3dB
- Frequency response : 70 - 20 000 Hz
- Material : Plastic enclosure and aluminium grille
- Holding : Wallmount bracket
- Connectors : Waterproof cable on gland IP55
- Power rotary knob : 60W 8Ω // 7,5 / 15 / 30 / 60W 100V
- Dimensions : 214x178 x 329 (H) mm
- Weight : 4,7 Kg

Code: H10919



**x2**

**New**

**EHP660IPW**

Tropical speaker 6" 100V 7.5 to 60W 8 Ohms

- Power outputs : 7,5 / 15 / 30 / 60W
- Voltage : 100V 8 Ohms
- Components : 6,5" + 1"
- Sensitivity (1W/1m): 90 dB, +/-3dB
- Frequency response : 70 - 20 000 Hz
- Material : Plastic enclosure and aluminium grille
- Holding : Wallmount bracket
- Connectors : Waterproof cable on gland IP55
- Power rotary knob : 60W 8Ω // 7,5 / 15 / 30 / 60W 100V
- Dimensions : 214x178 x 329 (H) mm
- Weight : 4,7 Kg

Code: H10920

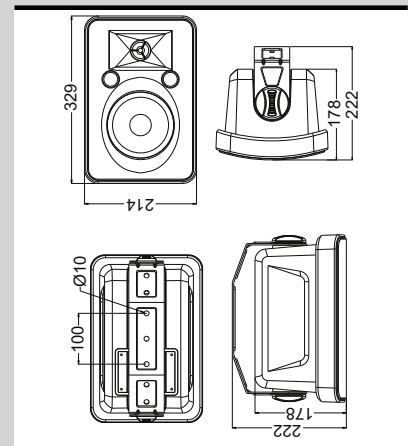

## HiFi Outdoor Speaker 100V



### High quality in a very discreet speaker

The EHP660 speakers can be used with a low impedance or a 100V line.

They are absolutely perfect to broadcast voice or music, and fit any kind of installation: shops, conference rooms, waiting rooms, places of worship...

The volume controller allows you to adjust it to your needs. permet de limiter le volume de la diffusion en fonction des besoins.

- + Use it indoor or outdoor
- + Elegant, refined black or white housing
- + Very discreet holding system, can be vertically or horizontally oriented
- + Requires a low-impedance or a 100V line





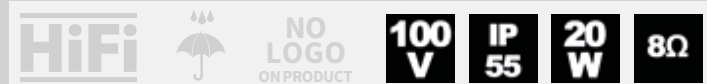
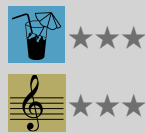
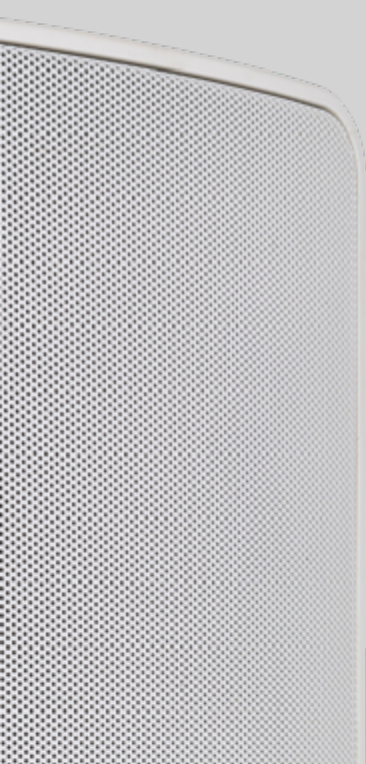

x2

New

**EHP420IPB**

Tropical speaker 4" 100V 2 to 20W 8 Ohms

- Power outputs : 2,5 / 5 / 10 / 20W
- Voltage : 100V 8 Ohms
- Components : 4" + 1"
- Sensitivity (1W/1m): 88 dB, +/-3dB
- Frequency response : 90-18 000 Hz
- Material : Plastic enclosure and aluminum grille
- Holding : Lyre d'accroche murale
- Connectors : Câble sur presse étoupe étanche IP55
- Power rotary knob : 20W 8Ω // 2,5 / 5 / 10 / 20W 100V
- Dimensions : 158x129 x 238 (H) mm
- Weight : 2,4 Kg

Code: H10917



x2

New

**EHP420IPW**

Tropical speaker 4" 100V 2 to 20W 8 Ohms

- Power output: 2.5 / 5 / 5 / 10 / 20W
- Power supply: 100V 8 Ohms
- Components: 4" + 1"
- Sensitivity (1W/1m): 88 dB, +/-3dB
- Frequency response: 90-18 000 Hz
- Construction: White ABS body and metal grid
- Hook: Wall bracket: Wall bracket
- Connections: Cable on IP55 waterproof cable gland
- Power selector switch: 20W 8Ω // 2.5 / 5 / 10 / 20W 100V
- Dimensions: 158x129 x 238 (H) mm
- Weight: 2,4 Kg

Code: H10918

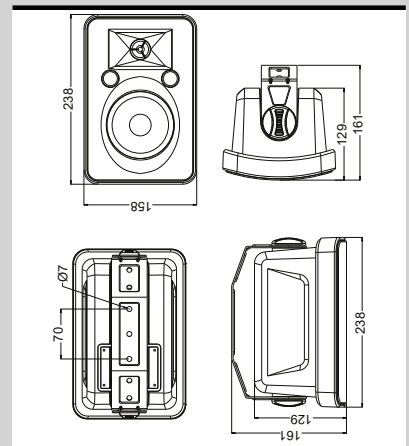

## HiFi Speaker 100V



### **Versatile, powerful speaker**

The EHP880 speakers can be used with a low impedance or a 100V line.

They are absolutely perfect to broadcast voice or music, and fit any kind of installation: shops, conference rooms, waiting rooms, places of worship... The volume controller allows you to adjust it to your needs.

- + 80W high-fidelity sound
- + Very discreet, black or white finishing
- + Built-in wall-mount bracket
- + Requires a low-impedance or a 100V line

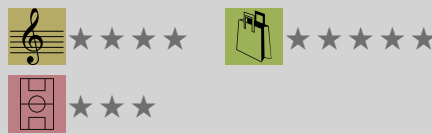

**EHP880B**

Speaker 8”+1” 100V 8 Ohms 80W

- Power outputs :
  - 20 or 40 or 80W at 100V
  - 10 or 20 or 40W at 70V
  - 50W into 8 Ohms
- Power supply : 100V/ 70V or 8 Ohms
- Impedances :
  - 125 or 250 or 500 Ohms
  - or 8 Ohms low impedance
- Components : 8” loudspeaker and 1” tweeter
- Sensitivity (1 M/1W) : 92 dB
- Frequency response : 70 Hz - 18 kHz
- Material : ABS enclosure, steel grill
- Holding system : Adjustable holding bracket
- Connectors : 2-pin connector
- Dimensions : 302 x 172 x 165 mm
- Weight : 3.4 kg

Code: H10212



**EHP880W**

Speaker 8”+1” 100V 8 Ohms 80W

- Power outputs :
  - 20 or 40 or 80W at 100V
  - 10 or 20 or 40W at 70V
  - 50W into 8 Ohms
- Power supply : 100V/ 70V or 8 Ohms
- Impedances :
  - 125 or 250 or 500 Ohms
  - or 8 Ohms low impedance
- Components : 8” loudspeaker and 1” tweeter
- Sensitivity (1 M/1W) : 92 dB
- Frequency response : 70 Hz - 18 kHz
- Material : ABS enclosure, steel grill
- Holding system : Adjustable holding bracket
- Connectors : 2-pin connector
- Dimensions : 302 x 172 x 165 mm
- Weight : 3.4 kg

Code: H10213

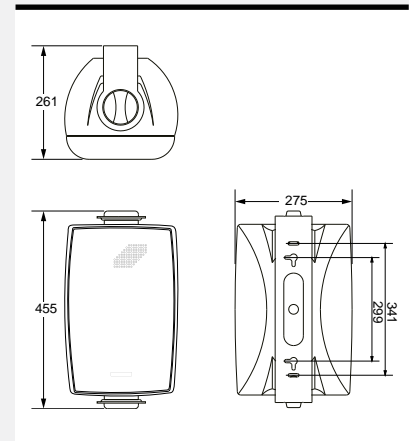

NOTE :

*Not compatible with ROT45*

## HiFi Speaker 100V



### Refined, compact, efficient

The EHP660 speakers can be used with a low impedance or a 100V line.

They are absolutely perfect to broadcast voice or music, and fit any kind of installation: shops, conference rooms, waiting rooms, places of worship...

The volume controller allows you to adjust it to your needs. permet de limiter le volume de la diffusion en fonction des besoins.

- + Use it indoor or outdoor
- + Elegant, refined black or white housing
- + Very discreet holding system, can be vertically or horizontally oriented
- + Requires a low-impedance or a 100V line

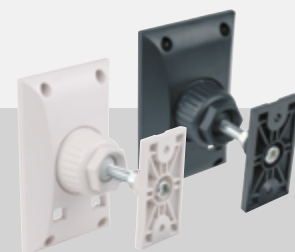

Swivel-mount brackets for EHP520 speakers.  
Black or white finishing available.

### ROT45b

Black version - code 9824

### ROT45w

White version - code 9825



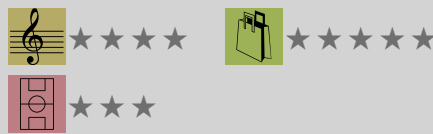

**EHP520B**

5" 70/100V ABS 5/10/20W 5" 70/100V wall speaker

- 2-way speaker
- RMS power output : 40 W into 8 Ohms
- Max power output : 150 W
- Power outputs : 40 W/ 20 W/ 10 W/ 5 W
- 8 Ohms/100 V/70 V
- Tweeter : 25 mm (1")
- Boomer : 125 mm (5")
- Frequency response : 80 Hz – 18 kHz
- Sensitivity(@ 1W / 1M): >89 dB
- External dimensions : 302 x 172 x 165 mm
- Net weight : 3.4 kg

Code: H9763



**EHP520W**

Wall speaker 5" 70/100V ABS 5/10/20W

- 2-way speaker
- RMS power output : 40 W into 8 Ohms
- Max power output : 150 W
- Power outputs : 40 W/ 20 W/ 10 W/ 5 W
- 8 Ohms/100 V/70 V
- Tweeter : 25 mm (1")
- Boomer : 125 mm (5")
- Frequency response : 80 Hz – 18 kHz
- Sensitivity(@1W / 1M) : >89 dB
- External dimensions : 302 x 172 x 165 mm
- Net weight : 3.4 kg

Code: H9762

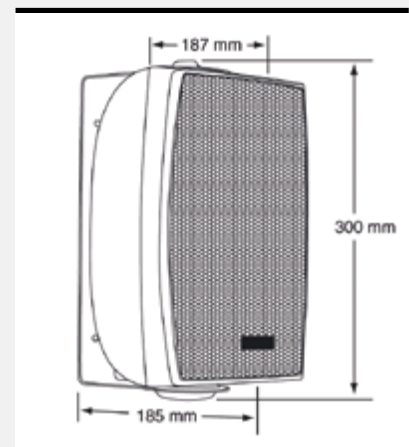

## HiFi Speaker 100V



### High quality in a very discreet speaker

The EHP410 speakers can be used with a low impedance or a 100V line.

They are absolutely perfect to broadcast voice or music, and fit any kind of installation: shops, conference rooms, waiting rooms, places of worship...

The volume controller allows you to adjust it to your needs. permet de limiter le volume de la diffusion en fonction des besoins.

- + High-fidelity sound
- + Designed to be used indoor
- + Very compact, white finishing
- + Built-in wall-mount bracket
- + Requires a low-impedance or a 100V line

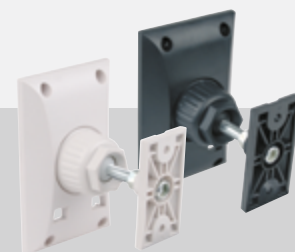

Swivel-mount brackets for EHP410 speakers.  
Black or white finishing available.

#### **ROT45b**

Black version - code 9824

#### **ROT45w**

White version - code 9825

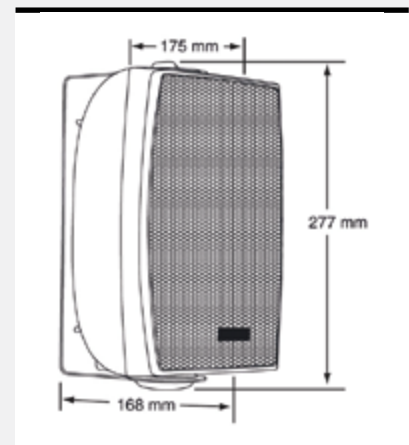

### EHP410B

4" 70/100V ABS wall speaker 2.5/5/10W

- 2-way speakers
- RMS power output : 20W into 8 Ohms
- Max power output : 70W
- Power outputs : 20W/10W/5W/2.5W
- 8 Ohms/100 V/70 V
- Tweeter : 25 mm (1")
- Boomer : 100 mm (4")
- Frequency response : 80 Hz – 18 kHz
- Sensitivity: >89 dB
- External dimensions : 250 x 160 x 145 mm
- Net weight : 1.45 kg

Code: H9761

### EHP410W

4" 70/100V ABS wall speaker 2.5/5/10W

- 2-way speakers
- RMS power output : 20W into 8 Ohms
- Max power output : 70W
- Power outputs : 20W/10W/5W/2.5W
- 8 Ohms/100 V/70 V
- Tweeter : 25 mm (1")
- Boomer : 100 mm (4")
- Frequency response : 80 Hz – 18 kHz
- Sensitivity: >89 dB
- External dimensions : 250 x 160 x 145 mm
- Net weight : 1.45 kg

Code: H9760

# 8" Ecessed HiFi speaker

## A discreet HiFi

The CHF860 are recessed speakers providing an incredible sound output. They are discreet and provide the same sound quality as classic top-of-the-range products.



NO  
LOGO  
ON PRODUCT



# CH



### CHF860

Hifi ceiling light 8" 2 ways 60W 8 Ohms

- 2-way speaker
- RMS power output : 60W
- Max power output : 250W
- Impedance : 8 Ohms
- Tweeter : 25 mm (1")
- Boomer : 165 mm (6.5")
- Frequency response: 40 Hz – 20 kHz
- Sensitivity: >90 dB
- Holding : 4 mouting clamp
- External dimensions (diameter and depth) : 280 x 180 mm
- Drill hole diameter : 247 mm
- Net weight : 2.48 kg

Code: H9909

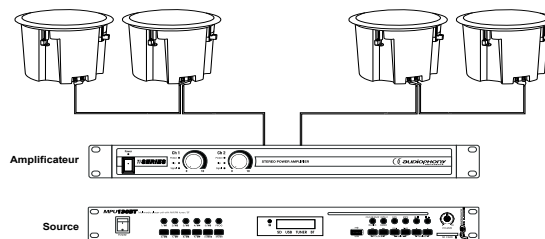
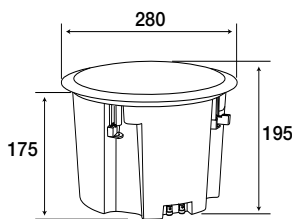



# IF860



# 2-way ceiling speaker 8Ω 8" 35W 100V

## High-quality voice and music

The CHP835 ceiling speaker features a 2-way coaxial speaker producing a very pure sound even at low volume.

The tweeter is incredibly efficient at transmitting a clear vocal reproduction.



NO  
LOGO  
ON PRODUCT



# CH



### CHF835

2-way ceiling speaker 35W 8" 8 Ohms

- Power outputs : 35W
- Impedance: 8 Ohms
- Components : 8" + 1"
- Sensitivity (1W/1m): 86 dB, +/-3dB
- Frequency response : 55-20 000 Hz
- Material : white plastic enclosure and magnetic grille
- Holding : 4 mouting clamp
- Dimensions : 260(diam) x 100 (H) mm
- Weight : 1,40 Kg

Code: H10965

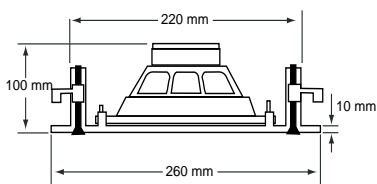

WALLAMPpad  
(Source et amplificateur)  
(Source and amplifier)

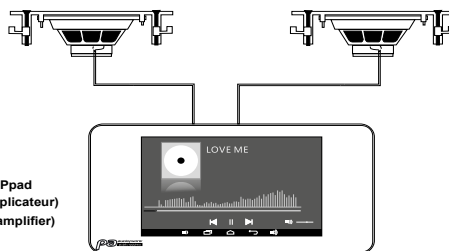



# IF835



New

INVISIBLE  
edge  
DESIGN

Magnetic grid and borderless



# 2-way ceiling speaker 8Ω 6.5" 60W 100V

## 100V and low impedance

The CHP660 is a 2-way high-quality and very versatile ceiling speaker.

The 6.5 coaxial loudspeaker produces a warm and generous sound output and can be operated with a 100V line or at low impedance thanks to its incredible sound box.

NO  
LOGO  
ON PRODUCT

100  
V

# CH



## CHP660

6.5" 2-way ceiling speaker 60W 8 Ohms and 70-100V

- 2-way speaker
- RMS power output : 60W into 8 Ohms
- Max power output : 200W into 8 Ohms
- Power outputs :
  - 1.25/2.5/5/10W into 70V and 100V
  - 60 W into 8 Ohms
- 8 Ohms/70 V/100 V
- Tweeter : 25 mm (1")
- Boomer : 165 mm (6.5")
- Frequency response : 56 Hz – 20 kHz
- Sensitivity: >90 dB
- Holding: 4 mouting clamp
- External dimensions (diameter and depth) : 240 x 140 mm
- Drill hole diameter : 208 mm
- Net weight : 1.75 kg

Code: H9910

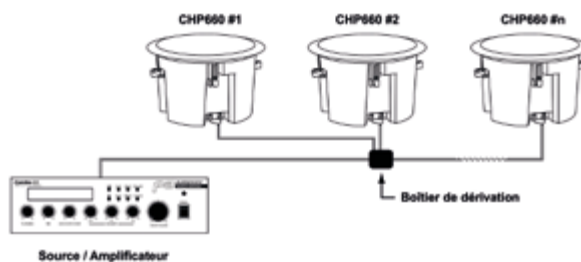
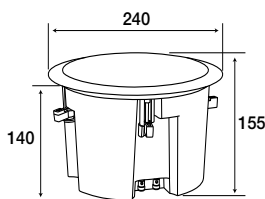

The volume controller allow you to adjust the volume to your needs.



# IP 660



# 2-way ceiling speaker 8Ω 6" 30W 100V

Recessed ceiling speaker for 100V and 8 Ohms amplifiers. Two voices speaker with passive crossover. Invisible edge design with magnetic grille.

NO  
LOGO  
ON PRODUCT

100  
V

# CH



## CHP630

2-way ceiling speaker 6" 100V 7.5/15/30W

- Power ratings: 7,5 / 15 / 30W
- Power outputs: 100V 8 Ohms
- Components: 6,5"
- Sensitivity (1W/1m): 88 dB, +/-3dB
- Frequency response: 60-20 000 Hz
- Construction: Black plastic enclosure and white magnetic grille
- Holding: 3 mouting clamp
- Connections: 4-contact connector
- Drill hole diameter: 210 mm
- Dimensions: 232(diam) x 90 (H) mm
- Weight: 1,85 Kg

Code: H10915

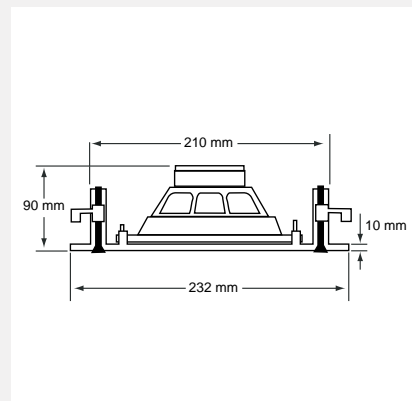

## CHP630GB

Black ceiling grid for CHP630

Code: H10989



# IP630



New

INVISIBLE  
edge  
DESIGN

Magnetic grid and borderless

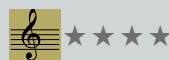

# 2-way ceiling speaker 8Ω 5" 20W100V

NO  
LOGO  
ON PRODUCT

100  
V

# CH



## CHP520

2-way ceiling speaker 5" 100V 5/10/20W

- Power ratings: 5 / 10 / 20W
- Power outputs: 100V 8 Ohms
- Components: 5".
- Sensitivity (1W/1m): 88 dB, +/-3dB
- Frequency response: 100-20 000 Hz
- Construction: Black plastic enclosure and white magnetic grille
- Holding: 3 mouting clamp
- Connections: 4-contact connector
- Drill hole diameter: 180 mm
- Dimensions: 203(diam) x 85 (H) mm
- Weight: 1,5 Kg

Code: H10914

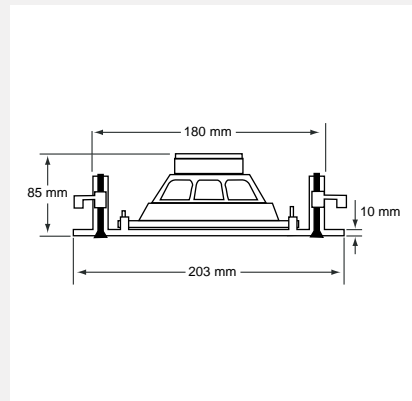

## CHP520GB

Black ceiling grid for CHP520

Code: H10988



# IP520



New

INVISIBLE  
edge  
DESIGN

Magnetic grid and borderless



# 2-way ceiling speaker 8Ω 6" 20W 100V

The CHP620 and CHP610 ceiling speakers feature a 2-way coaxial speaker producing a very pure sound even at low volume.

The tweeter is incredibly efficient at transmitting a clear vocal reproduction.

**100  
V**

# CH



## CHP620

2-way ceiling speaker 6" 100V / 8 Ohms ABS 10/20W

- 2-way speaker
- RMS power output : 20W
- Max power output : 30W
- Power outputs : 20W or 10W
- 100 V
- Tweeter : 25 mm (1.5")
- Boomer : 165 mm (6.5")
- Frequency response : 85 Hz - 18 kHz
- Sensitivity: >98 dB
- Connections: 4-contact connector
- External dimensions (diameter and depth) : 233 x 118 mm
- Drill hole diameter : 200 mm
- Net weight : 1.7 kg

Code: H9757

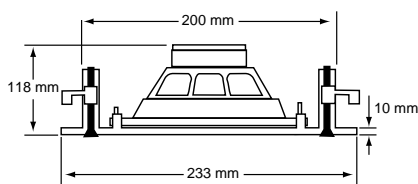



# IP620

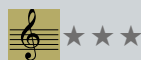

# 2-way ceiling speaker 8Ω 6" 10W 100V

The CHP620 and CHP610 ceiling speakers feature a 2-way coaxial speaker producing a very pure sound even at low volume.

The tweeter is incredibly efficient at transmitting a clear vocal reproduction.

**100  
V**

# CH



## CHP610

2-way ceiling speaker 6" 100V ABS 2.5/5/10W

- 2-way speaker
- RMS power output: 10W
- Max power output: 18W
- Power output: 10W, 5W or 2.5W
- 100 V
- Tweeter: 25 mm (1")
- Boomer: 165 mm (6.5")
- Frequency response: 110 Hz - 16 KHz
- Sensitivity: 93 dB, +/-3dB
- Connections: 4-contact connector
- External dimensions (diameter and depth) : 230 x 90 mm
- Drill hole diameter : 200 mm
- Net weight : 1.4 kg

Code: H9756

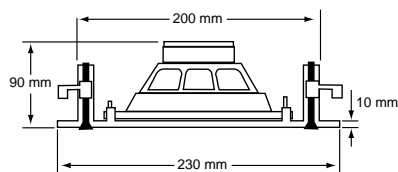



# IP 610



# Double cone ceiling speaker 6" 6W 100V

100  
V

# CH



## CHP606

Double cone ceiling speaker 6" 100V ABS 3/6W

- Dual cone loudspeaker
- RMS power output : 6W
- Max power output : 10W
- Power outputs : 6W or 3W
- 100V
- Loudspeaker : 165 mm (6.5")
- Frequency response : 110 Hz – 13 kHz
- Sensitivity >90 dB
- Holding: 2 string grip
- External dimensions (diameter and depth) : 230 x 90 mm
- Drill hole diameter : 200 mm
- Net weight : 0.9 kg

Code: H9755

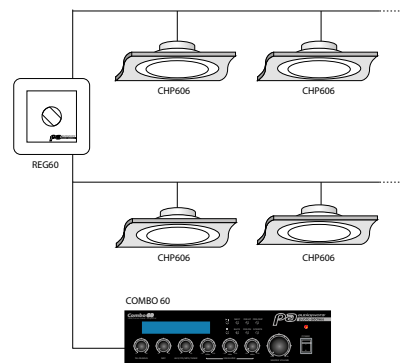
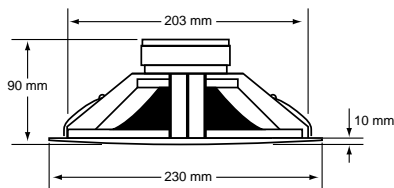

## Example

The REG60 allows you to create different zones with their own volume. The COMBO60 allows you to amplify up to 20 CHP606 speakers.

# IP 606





# Double cone ceiling speaker 5" 6W 100V

NO LOGO ON PRODUCT

100 V

# CH



## CHP506

Double cone ceiling speaker 5" ABS white 100V 3/6W

- Power ratings: 3/6W
- Power outputs: 100V
- Components: 5".
- Sensitivity (1W/1m): 93 dB, +/-3dB
- Frequency response: 100-15 000 Hz
- Construction: white ABS body
- Holding: 2 string grip
- Connections: 3-contact connector
- Drill hole diameter: 145mm
- Dimensions: 160(diam) x 54 (H) mm
- Weight: 500 g

Code: H10912

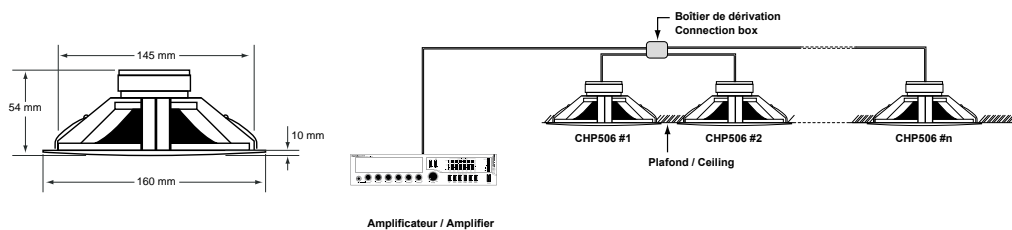



# P506



New



# Subwoofer 8Ω 8" 60W 100V

HiFi

NO  
LOGO  
ON PRODUCT

# CH

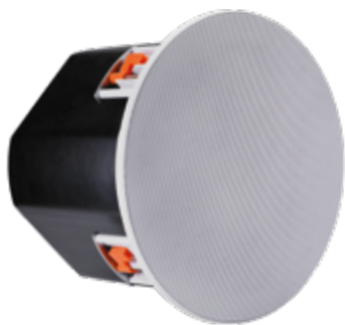

## CHPSUB

Ceiling speaker 8" 20/40/60W 100V - 60W 8 Ohms

- Power: 20/40/60W at 100V and 60W at 8 Ohms
- Frequency response: 80Hz - 200Hz
- Boomer: 8"
- Connector: 4-pin Pheonix connectors
- Dimensions: 295(diam) x 215 (H) mm
- Drilling diameter: 266 mm
- Net weight: 5kg

Code: H10533

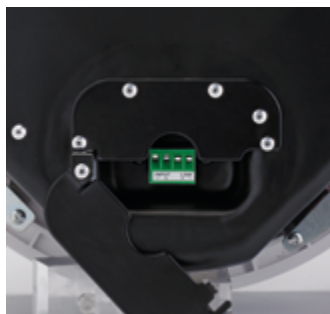
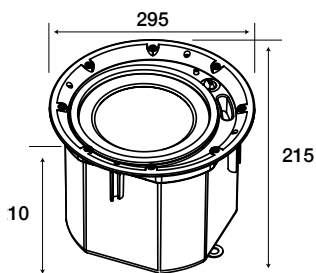

## Example

The REG60 allows you to create different zones with their own volume. The COMBO60 allows you to amplify up to 20 CHP606 speakers.



# IPSUB

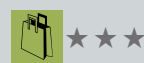

# 2-way ceiling speaker 8Ω 6" 30W 100V

A high-quality sound in all circumstances. Square recessed ceiling speaker for 100V amplifiers. Two voices speaker.

NO  
LOGO  
ON PRODUCT

100  
V

# CH



## CHP630SQ

2-way square ceiling speaker 6" ABS white 100V 7,5/15/30W

- Power outputs: 7,5 / 15 / 30W
- Voltage: 100V 8 Ohms
- Components: 6.5" x1"
- Sensitivity (1W/1m): 88 dB, +/-3dB
- Frequency response: 90-20 000 Hz
- Material: White plastic enclosure
- Holding: 4 mouting clamp
- Drill hole diameter: 210mm
- Dimensions: 220 x 220 x 95 mm
- Weight : 980 g

Code: H10974

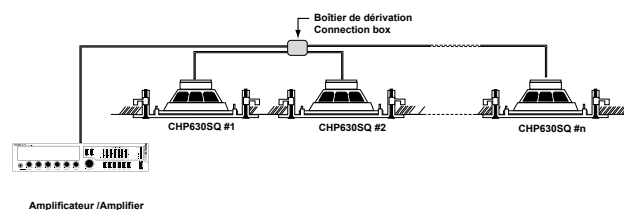
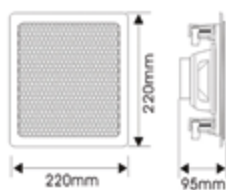



# P630SQ



# 2-way ceiling speaker 8Ω 5" 20W 100V

NO  
LOGO  
ON PRODUCT

100  
V

# CH



## CHP520SQ

Square ceiling speaker 2-way 5" ABS white 100V 5/10/20W

- Power ratings: 5 / 10 / 20W
- Power outputs: 100V 8 Ohms
- Components: 4" + 1/2"
- Sensitivity (1W/1m): 89 dB, +/-3dB
- Frequency response: 90-18 000 Hz
- Construction: White plastic enclosure and metallic grille
- Holding: 4 mouting clamp
- Connections: 4-contact connector
- Drill hole dimensions: 156 x 156 mm
- Dimensions: 190 x 190 x 80 (H) mm
- Weight: 1,3 Kg

Code: H10916

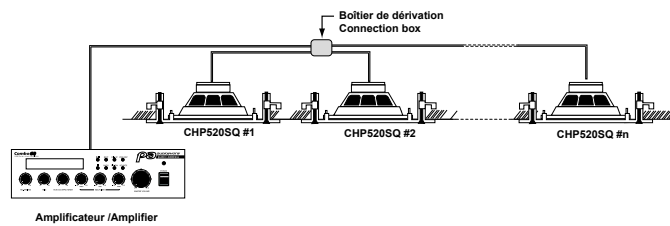
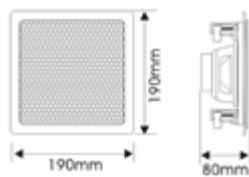

# P520SQ



New





# Subtle, wide- diffusion.

The multi-speaker system inside the columns allows a perfect horizontal sound diffusion while decreasing vertical sound propagation.

This was designed to avoid echoes from ceilings, in places with particularly complex acoustic configurations. The column is the perfect tool for any speech in large spaces.

- + Perfect for voice reproduction in places of worship
- + Aluminium grille and housing
- + Weatherproof
- + Operates at 100V

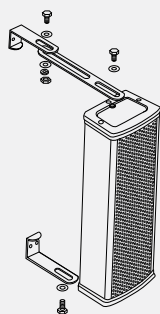

Columns are supplied with wall-mounting brackets







### CLS880

Aluminium column 8 x 2.5" 100V 40/80W - IP44

- Power: 40/80V
- Frequency response: 250Hz – 15KHz
- SPL (@1m): 97 dB
- Operates at 100V
- Speaker: 8 x 2,5"
- Connector: Cable gland securing the cable
- IP protection: IP44
- Dimensions: 104x 73 x 690 mm
- Weight : 3.34 kg

Code: H10517

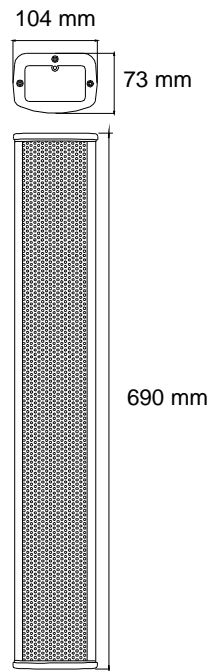

### CLS660

Aluminium column 6 x 2.5" 100V 30/60W - IP44

- Power 30/60W
- Frequency response: 250Hz – 15KHz
- SPL (@1m]: 96 dB
- Operates at 100V
- Speaker: 6 x 2,5"
- Connector: Cable gland securing the cable
- IP protection: IP44
- Dimensions: 104x 73 x 550 mm
- Weight : 2.6 kg

Code: H10516

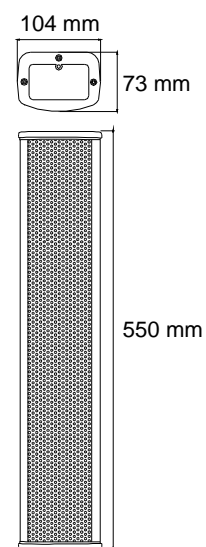

# Subtle, wide- diffusion.

The multi-speaker system inside the columns allows a perfect horizontal sound diffusion while decreasing vertical sound propagation.

This was designed to avoid echoes from ceilings, in places with particularly complex acoustic configurations. The column is the perfect tool for any speech in large spaces.

- + Perfect for voice reproduction in places of worship
- + Aluminium grille and housing
- + Weatherproof
- + Operates at 100V

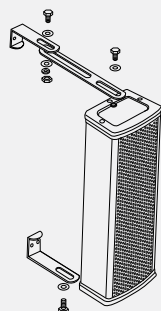
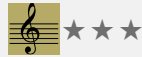

Columns are supplied with wall-mounting brackets

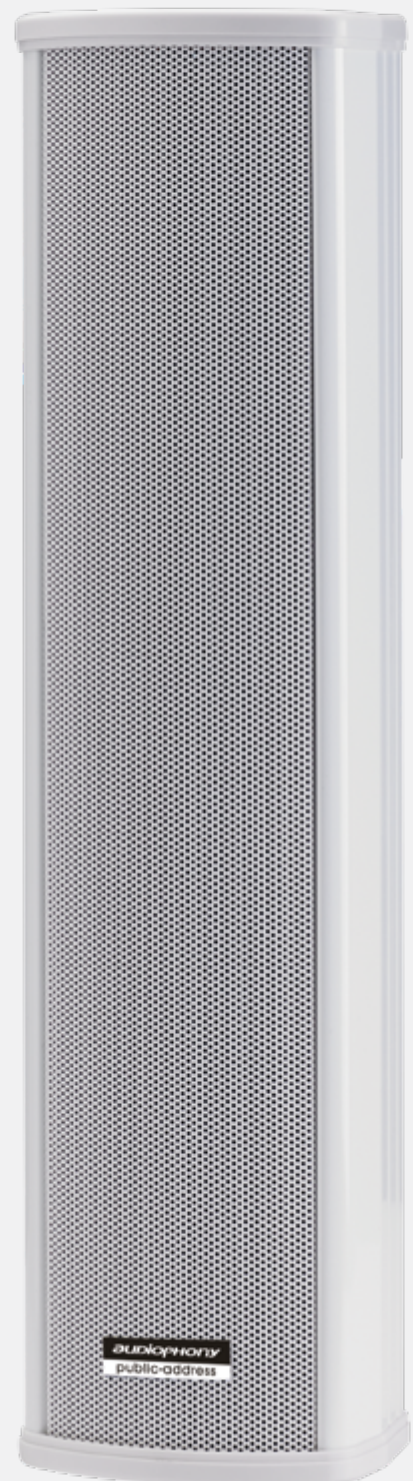



### CLS440

Aluminium column 4 x 2.5" 100V 20/40W- IP44

- Power 20/40W
- Frequency response: 250Hz – 15KHz
- SPL (@1m): 95 dB
- Fonctionne en 100V
- Speaker : 4 x 2,5"
- Connector: Cable gland securing the cable
- IP Protection: IP44
- Dimensions 104 x 73 x 402 mm
- Weight : 1.94 kg

Code: H10515

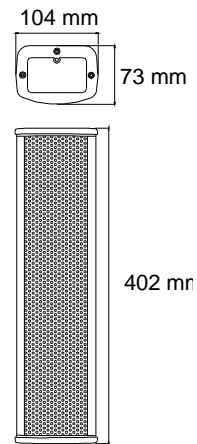

### CLS220

Aluminium column 2 x 2.5" 100V 10/20W- IP44

- Power 10/20W
- Frequency response: 250Hz – 15KHz
- SPL (@1m): 94 dB
- Operates at 100V
- Speaker: 2 x 2,5"
- Connector: Cable gland securing the cable
- IP Protection: IP44
- Dimensions: 104 x 73 x 262 mm
- Weight : 1.4 kg

Code: H10514

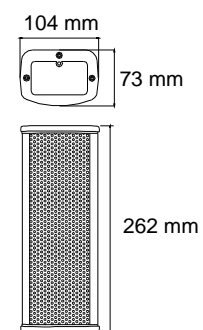





## The triphonic Systema sound systems100V

HiFi

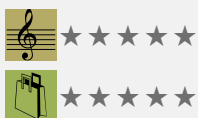

- + Spherical design
- + 2-way coaxial loudspeaker

- + High-performance self-powered subwoofer
- + Controls up to 4 satellites simultaneously
- + Integral steel mesh grille
- + XLR/Jack and RCA inputs
- + An independent LF volume controller







### OHO-SYSTEMA1B

Audio system with 8" 150W active 8" cabinet + 2 x 50W spherical satellites

#### SATELLITES:

- Power output : 50W RMS
- Frequency response : 100 Hz - 25 KHz
- Sensitivity (1W@1m) : 89 dB
- Nominal impedance : 8 Ohms
- Boomer : 3"
- Tweeter : 1" compression
- Connector : Mount-integrated terminal
- Dimensions : 115 mm diam
- Weight : 0.7 kg

#### SUBWOOFER:

- Power output : 150W
- Frequency response : 52 - 200 Hz
- Max SPL (@1m) : 120 dB
- Boomer : 8"
- Dimensions : 360 x 250 x 250 mm
- Weight : 10.3 kg

#### AMPLIFICATION:

- LF : 1 x 150W
- HF : 2 x 40W RMS / 4 Ohms
- Sub phase controller 0/180
- Sub and Master adjustable levels
- Connectors : 2 x Combo XLR/Jack and 2x RCA inputs

#### SATELLITES TERMINAL

- Indicators : Power/Signal/Clip
- Protections : Short-circuits/Thermal and limiter
- Convection cooled (totally silent)

Code: H10156



### OHO-350B

Compact satellite with a magnetised base - 50W

- Power output : 50W RMS
- Frequency response : 100 Hz - 25 KHz
- Sensitivity (1W@1m) : 89 dB
- Nominal impedance : 8 Ohms
- Boomer : 3"
- Tweeter : 1" compression
- Connector : Mount-integrated terminal
- Dimensions : Diam 115 mm
- Weight : 0.7 kg

Code: H10125



### OHO-350W

Compact satellite with a magnetised base - 50W

- Power output : 50W RMS
- Frequency response : 100 Hz - 25 KHz
- Sensitivity (1W@1m) : 89 dB
- Nominal impedance : 8 Ohms
- Boomer : 3"
- Tweeter : 1" compression
- Connector : Mount-integrated terminal
- Dimensions : Diam 115 mm
- Weight : 0.7 kg

Code: H10124



### MIO-SUB8150B

150W active 8" box with 2 x 40W/4 Ohms output

#### SUBWOOFER:

- Power output : 150W
- Frequency response : 52 - 200 Hz
- Max SPL (@1m) : 120 dB
- Boomer : 8"
- Dimensions : 360 x 250 x 250 mm
- Weight : 10.3 kg

#### AMPLIFICATION:

- LF : 1 x 150W
- HF : 2 x 40W RMS / 4 Ohms
- Sub phase controller 0/180
- Sub and Master adjustable levels
- Connectors : 2 x Combo XLR/Jack and 2x RCA inputs

Code: H10153





## The triphonic Systema sound systems100V

HiFi

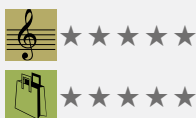

- + 8 Ohms, 25Watts speaker
- + Designed to be used indoor
- + Compact satellites with an orientable mounting bracket
- + The terminal is integrated within the support

- + High-efficiency self-powered subwoofer
- + Controls up to 4 satellites simultaneously
- + Steel mesh protective grille
- + XLR/Jack and RCA inputs
- + An independent LF volume controller





### MIO-SYSTEMA1B

Audio system with 6.5" 100W active box and 2 x 25W satellites

#### SATELLITES:

- Power output : 25W RMS
- Frequency response : 200 Hz - 15 KHz
- Max SPL (@1m) : 110 dB
- Nominal impedance : 8 Ohms
- Boomer : 2X2.75"
- Connector : Mount-integrated terminal
- Dimensions : 90x136x180mm
- Weight : 0.950 kg

#### SUBWOOFER:

- Power : 100W
- Frequency response : 50 - 200 Hz

- Max SPL (@1m) : 112 dB
- Boomer : 6.5"
- Dimensions : 320 x 240 x 200 mm
- Weight : 8.5 kg

#### AMPLIFICATION:

- LF : 1 x 100W
- HF : 2 x 25W RMS / 4 Ohms
- Sub phase controller 0/180
- Sub and Master adjustable levels
- Connectors : 2 x Combo XLR/Jack and 2x RCA inputs

#### SATELLITES TERMINAL:

- Indicators : Power/Signal/Clip
- Protections : Short-circuits/Thermal and limiter

Code: H10148

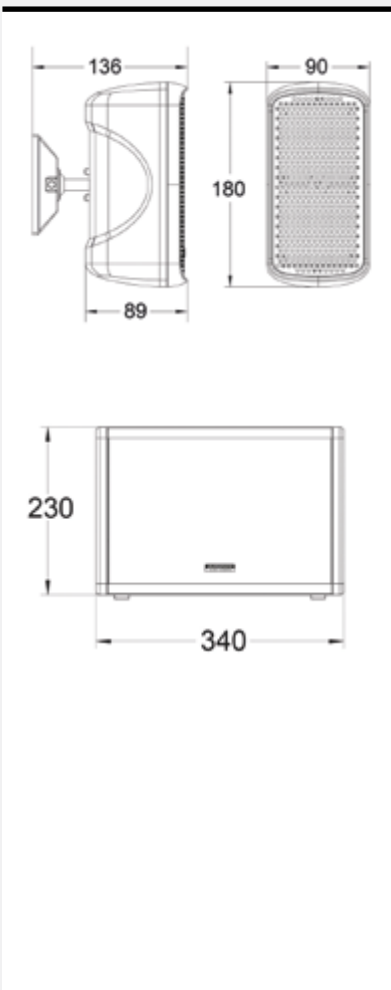

### MIO-SAT225B

Satellites 2 x 2" 25W 8 Ohms with wall bracket

- Power output : 25W RMS
- Frequency response : 200 Hz - 15 KHz
- Max SPL (@1m) : 110 dB
- Nominal impedance : 8 Ohms
- Boomer : 2X2.75"
- Connector : Mount-integrated terminal
- Dimensions : 90x136x180mm
- Weight : 0.950 kg

Code: H10150



### MIO-SUB6100B

6.5" 100W active 100W box with 2 x 25W/4 Ohms output

#### SUBWOOFER:

- Power : 100W
- Frequency response : 50 - 200 Hz
- Max SPL (@1m) : 112 dB
- Boomer : 6.5"
- Dimensions : 320 x 240 x 200 mm
- Weight : 8.5 kg

#### AMPLIFICATION:

- LF : 1 x 100W
- HF : 2 x 25W RMS / 4 Ohms
- Sub phase controller 0/180
- Sub and Master adjustable levels
- Connectors : 2 x Combo XLR/Jack and 2x RCA inputs

Code: H10149





## The triphonic Systema sound systems100V

HiFi

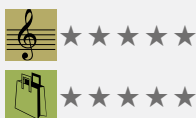

- + 8 Ohms, 40Watts speaker
- + Designed to be used indoor
- + Wooden enclosure - 2-way
- + Compact satellites with an orientable mounting bracket

- + High-efficiency self-powered subwoofer
- + Controls up to 4 satellites simultaneously
- + Steel mesh protective grille
- + XLR/Jack and RCA inputs
- + An independent LF volume controller







### MIO-SYSTEMA2B

Audio system with 8" 150W active 8" cabinet + 2 x 40W 4" satellites

#### SATELLITES:

- Power output : 40W RMS
- Frequency response : 120 Hz - 16 KHz
- Max SPL (@1m) : 116 dB
- Nominal impedance : 8 Ohms
- Boomer : 4"
- Tweeter : 1" compression
- Connector : Rear terminal
- Dimensions : 155x170x220 mm
- Weight : 2.6 kg

#### SUBWOOFER:

- Power output : 150W
- Frequency response : 52 - 200 Hz
- Max SPL (@1m) : 120 dB

- Boomer : 8"
- Dimensions : 360 x 250 x 250 mm
- Weight : 10.3 kg

#### AMPLIFICATION:

- LF : 1 x 150W
- HF : 2 x 40W RMS / 4 Ohms
- Sub phase controller 0/180
- Sub and Master adjustable levels
- Connectors : 2 x Combo XLR/Jack et 2x RCA inputs

#### SATELLITES TERMINAL

- Indicators : Power/Signal/Clip
- Protections : Short-circuits/Thermal and limiter
- Convection cooled (totally silent)

Code: H10152

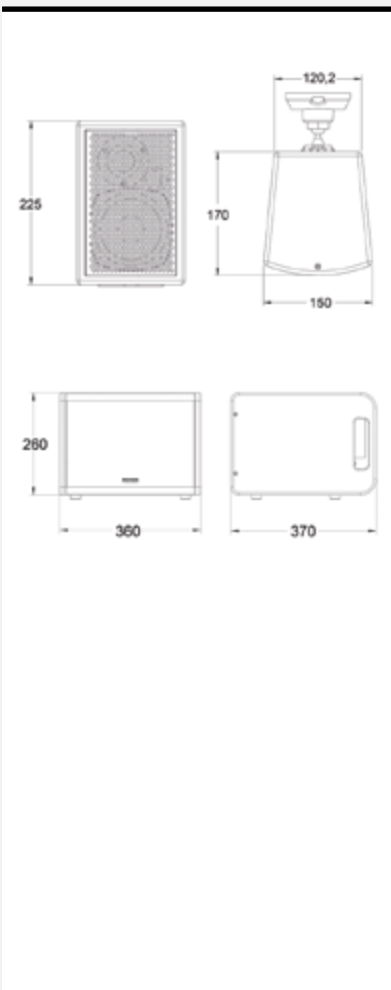

### MIO-SAT440B

Satellites 4 x 1" 40W/8 Ohms with wall bracket

- Power output : 40W RMS
- Frequency response : 120 Hz - 16 KHz
- Max SPL (@1m) : 116 dB
- Nominal impedance : 8 Ohms
- Boomer : 4"
- Tweeter : 1" compression
- Connector : Rear terminal
- Dimensions : 155x170x220 mm
- Weight : 2.6 kg

Code: H10154



### MIO-SUB8150B

150W active 8" box with 2 x 40W/4 Ohms output

#### SUBWOOFER:

- Power output : 150W
- Frequency response : 52 - 200 Hz
- Max SPL (@1m) : 120 dB
- Boomer : 8"
- Dimensions : 360 x 250 x 250 mm
- Weight : 10.3 kg

#### AMPLIFICATION:

- LF : 1 x 150W
- HF : 2 x 40W RMS / 4 Ohms
- Sub phase controller 0/180
- Sub and Master adjustable levels
- Connectors : 2 x Combo XLR/Jack and 2x RCA inputs

Code: H10153

# The magnetic induction loop

## Important public places

---

### The earring loop

A hearing loop is a magnetic field diffusion system for people with hearing loss equipped with a hearing aid. The installation consists of an electrical wire that runs around the periphery of the room forming a loop.

A magnetic loop is mainly installed in a room.



### The magnetic field

The magnetic field generated by the loop around the periphery of the room will pass through the coil of the induction prosthesis. The person with hearing loss may receive the information.

### How does it work?

In most cases, the magnetic loop is installed on the periphery of the room using a copper wire or tape (BM-CU 50/100). There are several types of loops depending on the size of the room, the need for confidentiality and the control of the magnetic field in order to limit interference.

1. The magnetic loop is connected to a specific amplifier (BM-A250 or BM-A1000) depending on the area to be covered.
2. The audio source to be transmitted is also connected to this amplifier
3. The installation then produces a magnetic field generated by the loop made in the room.
4. The magnetic field is picked up by the hearing instrument (in position «T»)
5. The loop amplifier can be used to complete an existing sound system in order to comply with regulations.

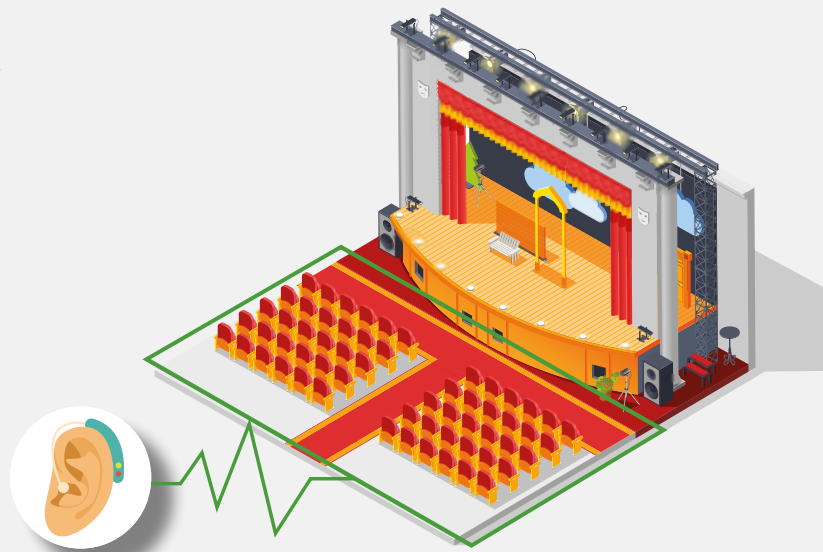

The installation of a hearing loop must be carried out and certified by a specialized installer  
The installer will be able to issue a certificate of conformity following a series of measurements carried out using the BM-SCAN

## Simple solutions for small places

With this system, sound from the speaker's microphone, sound equipment, television set or other source is transmitted wirelessly to the person's hearing aid. The latter can thus hear it without being disturbed by any ambient noise.



### SOLUTION N°1 - LOOP AMPLIFIER KIT

Ideal for small, fixed counter installations.  
Ideal for small fixed installations (50 m2 Max) and privacy area.

It can be used to equip:

- counters
- reception banks
- counters
- TV lounge

This kit is equipped with a very compact amplifier, a surface microphone and a loop. It is easy to conceal and install.

Magnetic loop  
To be hidden in  
the counter



### SOLUTION N°2 - Autonomous terminal on battery

Add-on solution, requires no installation

This portable loop system makes it very easy to equip an office or counter.

Made of ABS, it includes a microphone, amplifier, rechargeable battery and induction loop.



### The hearing aid

It has a coil often called «T» or «T-coil».  
This coil is placed inside the prosthesis. The latter is stimulated by the magnetic field emitted by the loop. A large part of conventional hearing instruments incorporate the «T» loop function.



Loi n° 2005-102 du 11 février 2005



### BM-PORTABLE

Portable and autonomous magnetic loop amplifier

- This portable loop system makes it easy to equip a desk or counter.
- Made of ABS, it has an integrated microphone, amplifier, rechargeable battery and an induction loop for a coverage of 1.2 m<sup>2</sup>
- Charger included

Code: H10799



### BM-KIT

Counter Magnetic Loop Amplifier KIT

Induction loop kit for equipping: counters, reception desks or service desks.

This kit includes:

- 1 x induction loop amplifier
- 1 x surface microphone
- 1 x loop
- 1 x power supply
- 2 x "Space adapted for the hearing-impaired" stickers
- 2 inputs: 1 microphone/line and 1 line
- Phantom power
- Compressor and noise limiter
- Output protection and control
- Power: 230V 50/60 Hz - 12V DC 1.5 A
- Size: 92 x 52 x 18 mm
- Weight: 0.850 kg

Code: H10795



### BM-A250

Magnetic loop amplifier for 250m<sup>2</sup> area

- 3 inputs: 2 line or microphone inputs
- Connector: 1 Phoenix and Combo
- 1 priority 100V input
- Monitoring and detection of power supply, amplifier and loop faults with NO-NC relay.
- Automatic gain control
- Correction control due to metal losses
- Power: 230V 50/60 Hz
- Size: 483 x 43 x 215 mm
- Weight: 2.47 kg

Code: H10796







### BM-A1000

Magnetic loop amplifier for 1000m<sup>2</sup> area

- 3 inputs: 2 line or microphone inputs
- Connector: 1 Phoenix and Combo
- 1 priority 100V input
- Monitoring and detection of power supply, amplifier and loop faults with NO-NC relay.
- Integrated phase shift module (output 90° or 0°)
- Automatic gain control
- Correction control due to metal losses
- Power: 230V 50/60 Hz
- Size: 483 x 43 x 215 mm
- Weight: 2.47 kg

Code: H10797



### BM-TEST

Prosthetic simulator for testing magnetic loop amplifiers

- BM-TEST is a compact listening device for magnetic induction loop systems. It can be used in different situations:
- To determine if an induction loop is working properly
  - For hearing-impaired people who do not wear a hearing aid
  - For wearers of hearing aids that do not have a "T" function
- The kit comprises:
- 1 x loop receiver
  - 1 x headset
  - 2 x AAA batteries
  - Frequency response: 20 Hz - 6 kHz
  - Battery life: >100 hours

Code: H10798



### BM-SCAN

Magnetic field meter

The BM-SCAN field strength meter has been designed to ensure that magnetic loop systems are installed and certified according to the new IEC 60118-4 standard. When these standards are met, the comfort of the user will be identical wherever he/she uses a hearing aid with the T position.

- 3.5 mm headphone jack socket
- Power supply: 9V battery (not included)

Code: H10878

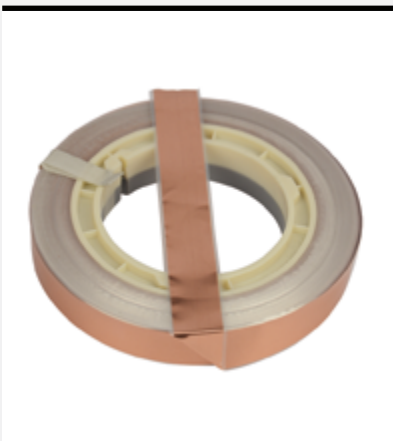

### BM-CU50

Copper tape 50 m - 18 mm wide x 0.1 mm thick

The BM-Cu50 is an 18-mm wide, 0.1-mm thick (1.8 mm<sup>2</sup> cross-section) copper tape insulated by a 0.05 mm Melinex band.

Cables specially designed for induction loops where the loop must go undercarpets or in places not suitable for conventional cables

- Resistance +/- 10Ω/m
- 50 m coil

Code: H10800



### BM-CU100

Copper tape 100 m - 18 mm wide x 0.1 mm thick

The BM-Cu100 is an 18-mm wide, 0.1-mm thick (1.8 mm<sup>2</sup> cross-section) copper tape insulated by a 0.05 mm Melinex band.

Cables specially designed for induction loops where the loop must go undercarpets or in places not suitable for conventional cables.

- Resistance +/- 10Ω/m
- 100 m coil

Code: H10801

# Technical Glossary

## Installation of an earring loop

The installation of a hearing loop must be carried out and certified by a specialized installer. The installer will be able to issue a certificate of conformity following a series of measurements made using the BM-SCAN.

**Our technicians are able to assist you in the development of your requests for magnetic loop installations thanks to our dedicated software. Below are some examples of a 60 m<sup>2</sup> room project**

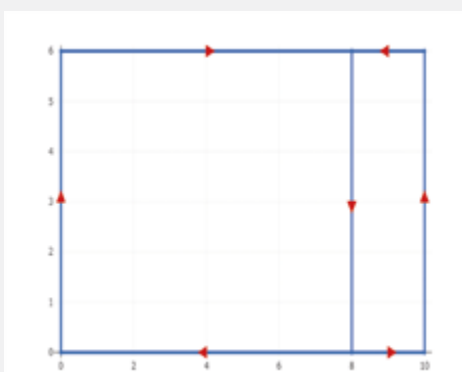

Visualization of the earring loop on a surface of 60 m<sup>2</sup>

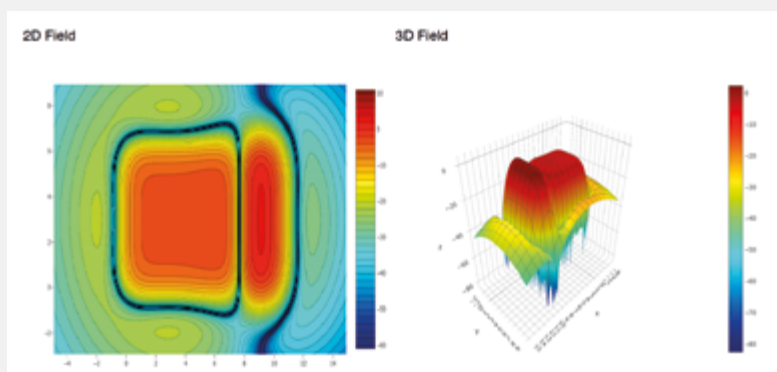

2D and 3D visualization of the optimal areas of the loop

| Wire section                    | Resistance Loop A |
|---------------------------------|-------------------|
| 0.5 mm <sup>2</sup>             | 2.07000 Ω         |
| 1.0 mm <sup>2</sup>             | 1.03500 Ω         |
| 1.5 mm <sup>2</sup>             | 0.69000 Ω         |
| 2.5 mm <sup>2</sup>             | 0.41400 Ω         |
| 4.0 mm <sup>2</sup>             | 0.25875 Ω         |
| Copper Foil 1.9 mm <sup>2</sup> | 0.54474 Ω         |
| Copper Foil 1x1 mm <sup>2</sup> | 1.03500 Ω         |

Cable diameter adapted to the project.

## Degree of water resistance of Audiophony PA products

### 1st digit:

**Protection against the infiltration of solids**

**IP 0X** no protection

**IP 1X** protected against solids larger than 50 mm (e. g. hand contact)

**IP 2X** protected against solids larger than 12 mm (e. g. hand finger)

**IP 6X fully** protected against dust

### 2nd digit

**Protection against liquid penetration**

**IP X0** no protection

**IP X5** protected against water jets from all directions with a hose

**IP X7** protected against the effects of immersion

**IP X8** submersible equipment under specified conditions

100V technology is the simplest and most economical solution for distributing sound from a single amplifier to several loudspeakers over a very long distance.

A transformer placed in the output amplifier raises the signal voltage to 100V. The speakers are equipped with a transformer that lowers this voltage and adapts it to power the loudspeaker.

The main advantage of this sound system technique is to eliminate power losses in the line because the intensity (Ampere) conveyed is lower. The economic advantage is that small section cables can be used for very long installation lengths.

The HPs connected in parallel on the line can deliver the same level or different power levels, in general they are equipped with selectors or terminals to choose the transformer winding corresponding to the power chosen for each diffusion point.

## Low impedance installation 8 Ω

Example of parallel installation with a 2 x 250W amplifier at 4 Ohms. Two 8 ohms speakers in parallel make 4 ohms, the output impedance of our amplifier is respected.

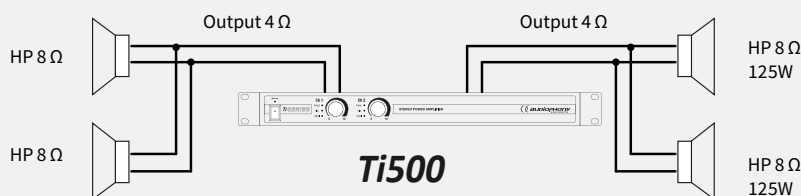

## 100V line installation

This configuration is used when the cable lengths are longer.

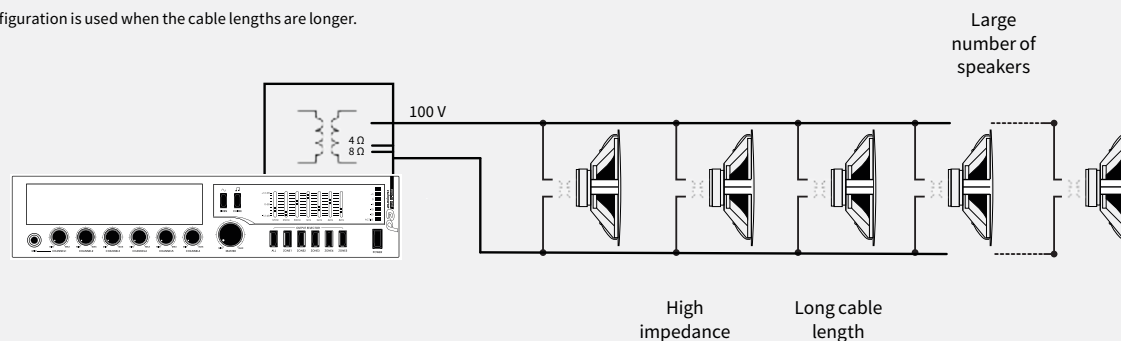

## Line 100V - Which section of HP cables to use?

Here is an indicative table of the cable diameter to be used according to distances and power:

| Amplifier power 100V | Cable cross-section for a distributed loading on the line |                   |                     |                     |                   |
|----------------------|---|-------------------|---------------------|---------------------|-------------------|
|                      | 0,75 mm <sup>2</sup>                                      | 1 mm <sup>2</sup> | 1,5 mm <sup>2</sup> | 2,5 mm <sup>2</sup> | 4 mm <sup>2</sup> |
| -                    |   |                   |                     |                     |                   |
| <b>30 W</b>          | 800   | 1000              | 1 600 m             | 2 600 m             | 4 200 m           |
| <b>60 W</b>          | 400   | 500               | 800 m               | 1 300 m             | 2 100 m           |
| <b>120 W</b>         | 200   | 250               | 400 m               | 6 000 m             | 1 000 m           |
| <b>240 W</b>         | 100   | 130               | 200 m               | 300 m               | 500 m             |

The speakers must always be wired in parallel and the sum of the speaker powers must not exceed the rated power under any circumstances, otherwise serious damage to the amplifier may result. Please use double insulated electrical cable that complies with the current standards.



## AUDIOPHONY® COMMERCIAL AUDIO

Conditions are available from your local dealer. Within the limit of available stocks.

May contain typographical errors. Because we are always looking for improvement, our products are subject to modifications. The technical specifications, pictures and illustrations are not contractual.

Catalogue updated on the 15th July 2019. AUDIOPHONY® Public address is registered trademark with the INPI and OHMI of HIT MUSIC SAS. Any reproduction of this catalogue, even partially, without the written authorization from HIT MUSIC SAS is prohibited.

Catalogue published by HIT MUSIC SAS and BEGLEC SA  
HITMUSIC SAS - Parc d'Activités Cahors Sud - 46230 Fontanes - France  
BEGLEC SA - 't Hofveld 2C - B-1702 Groot-Bijgaarden - Belgium

Photo credits : Studio ZE and © Shutterstock - Design : HITMUSIC SAS



ENGLISH CATALOGUE - CODE: 10614

