

BEGLEC HITMUSIC



2019 EDITION

 audiophony®

 Contest® 

 BriteQ

 JB SYSTEMS

 SYNQ

 JVC

 Hilec
LIGHT & SOUND ACCESSORIES

EDITO

The BEGLEC HITMUSIC group is getting structured and moving forward.

In this voluntary B to B catalogue, you will find our global 2019 offer. Whether you are a store, an installer, a service provider or a distributor, the brands of the group are becoming more professional every year to provide you with solutions adapted to your needs.

Our technical team is growing, with 17 technicians at the service of product development and after-sales service.

We are working on our logistics and inventory management to serve you better. Our warehouses in France and Belgium are there to supply you as quickly as possible.

Finally, our commercial team is at your disposal to handle all your requests.

The BEGLEC HITMUSIC group is a team of 60 people working together!

Discover our global 2019 offer, many new products are launched to create this energy that drives us all forward. This tool is there to help you in your daily life.

Thank you for your confidence all year round!

Luc de BAUW

Associate - Director BEGLEC – Purchase Director of the group

Pierre DENJEAN

Associate - President HITMUSIC – Sales and Marketing Director of the group

Marc de BAUW

Associate



WHERE ARE WE?



7

EXCLUSIVE BRANDS

17

PEOPLE DEDICATED TO TECHNICAL DEPARTMENT

2317

PRODUCTS REFERENCED IN THIS CATALOGUE

HIT MUSIC SAS

Parc d'Activités Cahors Sud
En Teste
46230 FONTAINES
France
Tel. : +33 (0)5 65 21 50 00
contact@hitmusic.eu

OPENING HOURS

Monday → Friday
9:00 to 12:00 & 13:15 to 17:15

BEGLEC NV

't Hofveld 2c
Industriezone "Gosset"
B-1702 Groot-Bijgaarden
Belgique
Tel. : +32 (0)2 481 70 70
orders@beglec.com

OPENING HOURS

Monday → Friday
8:30 to 12:15 & 13:00 to 17:00

SUMMARY

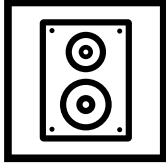

P6
SOUND

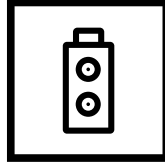

P66
PORTABLE SOUND



P74
COMMERCIAL AUDIO

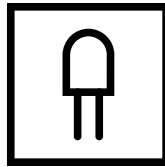

P100
LIGHT INTEGRATION



P124
LIGHT



P204
EFFECT MACHINES



P214
FLIGHT-CASES

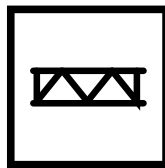

P224
TRUSS

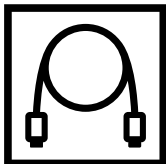

P268
ACCESSORIES

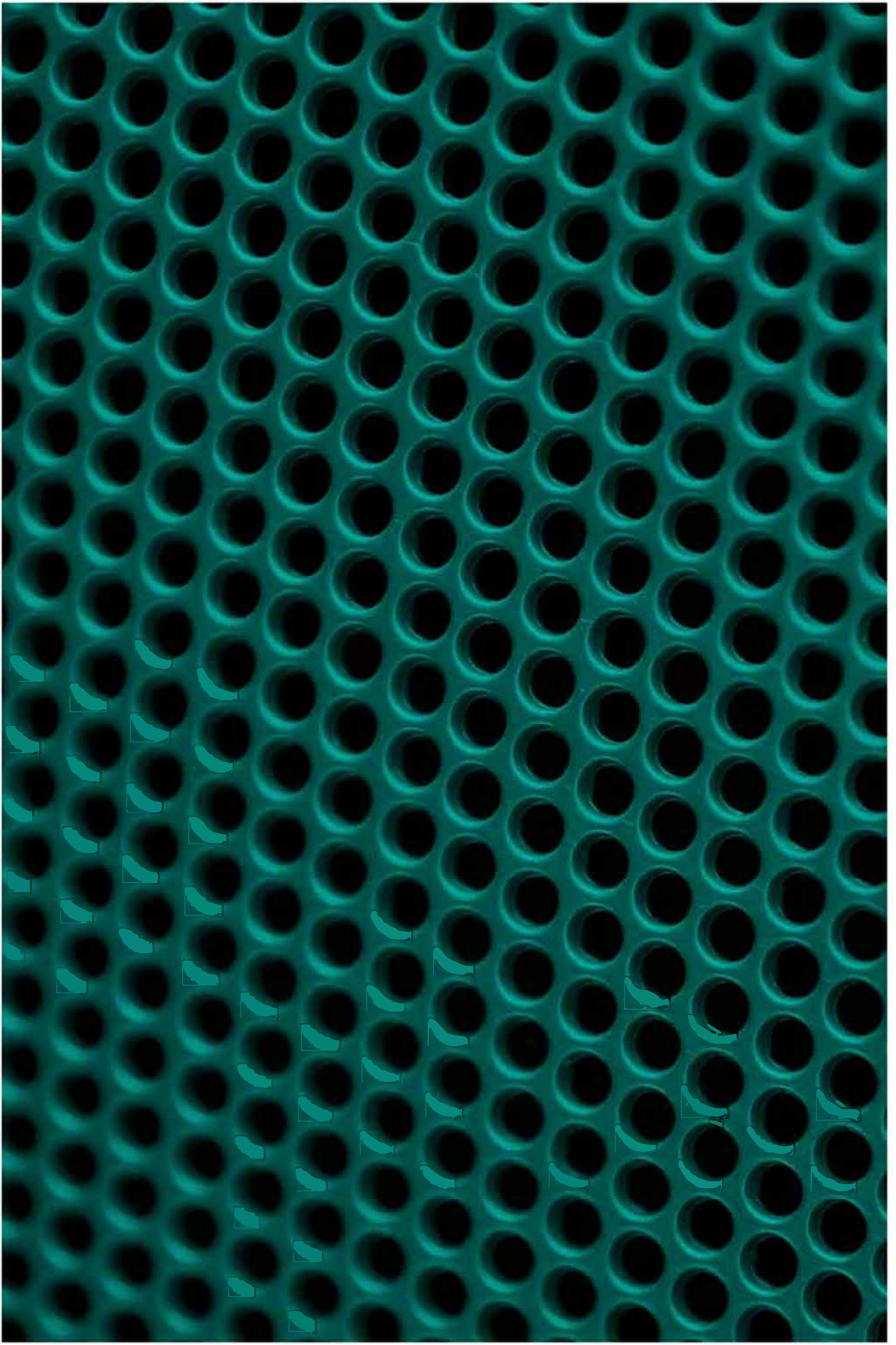

SOUND

ACTIVE SYSTEMS
ACTIVE SPEAKERS
PASSIVE SPEAKERS
SUBWOOFERS
AMPLIFIERS
SOUND PROCESSING
MIXERS
MIDI CONTROLLERS
CD PLAYERS
TURNTABLES
WIRED MICROPHONES
WIRELESS MICROPHONES
HEADPHONES

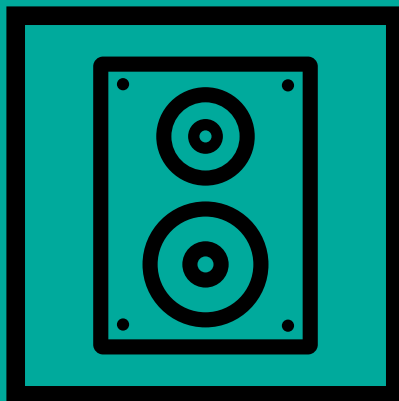

ILINE COLUMN ARRAY

Complete iLINE COLUMN ARRAY set



“Column Array” column systems

Aesthetically pleasing, the system comes with 2 families of columns. One for installation with columns iLINE23, iLINE43, iLINE83, and the other for stage performance with the iLiNE83B model.

They are linked and powered by an active subwoofer, the iLINEsub12A which embeds a double amplification of 700W/5 Ohms in class D for the columns and 700W/4 Ohms for the lower part because we can also add the iLINEsub12A as a reinforcement, which is the passive version of the subwoofer.

Modulate your desires.

Whether for mobile or fixed use, the system answers all your problems.

The system offers multiple possible combinations, for example, 2 columns, 1 subwoofer or 2 subwoofers, 2 columns, etc.

Once controlled by an active subwoofer, the iLINEsub12P passive subwoofers can supply the satellites for numerous configurations.





A system that travels well.

Lightweight and robust, the subwoofers are made of a very resistant wood, Finnish birch multi-ply plywood with a protective polyurethane resin coating, which is very resistant to weather and scratches.

You can transport your entire iLINE system anywhere.

Touch the power, that's all!

If you want to touch the system's sound settings, an "iLINEbox" USB to RJ45 converter is sold separately. This box is needed if you want to adjust the built-in DSP.

The native DSP is preset to factory settings in order to ensure optimal system behaviour.



Only compatible with Windows



ILINE COLUMN ARRAY

Discover the different configurations available to purchase.



iLINE
Stereo configuration 2.1 - 1020W RMS

Code : H10879



- 2x iLINE83 (H10756)
- 2x iLINEsub12A (zH10761)
- 1x iLINEbox (H10762)
- 2x CAB-200 (H8245)
- 2x CSP215/6 (H9841)



iLINE
Mono configuration 510W RMS

Code : H10880



- 1x iLINE83B (H10758)
- 1x iLINEspace60 (H10759)
- 1x iLINEsub12A (H10761)
- 1x iLINEbox (H10762)



iLINE
Stereo configuration 2040W RMS

Code : H10881



- 4x iLINE83B (H10758)
- 2x iLINEsub12P (H10763)
- 2x iLINEsub12A (H10761)
- 2x iLINEcord60 (H10764)
- 1x iLINEbox (H10762)



iLINE
Mono configuration 1020W RMS

Code : H10882



- 2x iLINE83B (H10758)
- 1x iLINEspace60 (H10759)
- 1x iLINEbase (H10760)
- 1x iLINEsub12P (H10763)
- 1x iLINEsub12A (H10761)
- 1x iLINEcord60 (H10764)
- 1x iLINEbox (H10762)
- 1x CSP215/3 (H9840)

The RJ45 cord that connects the iLINEbox to the iLINEsub12A is not supplied.
See the LINK-RJ cords in accessories section
Available in multiple lengths





iLINE
Stereo installation combination - 2680W
RMS

Code : H10883



8x iLINE83 (H10756)
8x iLINE83sup (H10757)
2x iLINEsub12P (H10763)
2x iLINEsub12A (H10761)
2x iLINEcord60 (H10764)
1x iLINEbox (H10762)
2x CSP215/3 (H9840)



iLINE
Stereo installation combination - 940W
RMS

Code : H10884



4x iLINE43 (H10754)
4x iLINE24sup (H10773)
2x iLINEsub12A (H10761)
1x iLINEbox (H10762)



iLINE
Mono installation combination - 510W
RMS

Code : H10885



4x iLINE23 (H10752)
4x iLINE23sup (H10753)
1x iLINEsub12A (H10761)
1x iLINEbox (H10762)



ILINE COLUMN ARRAY

○ Available in white finish

● Available in black finish



iLINE83B/ iLINE83Bw
160W @ 16 Ohms column with 8 3-inch speakers - with stackable connector base

Code : H10758 (black)
Code : H10939 (white)



iLINE83/ iLINE83w
160W @ 16 Ohms column with 8 3-inch speakers for installation

Code : H10756 (black)
Code : H10938 (white)



**iLINE83sup
iLINE83sup/w**
Wall bracket for iLINE83 column

Code : H10757 (black)
Code : H10940 (white)



iLINE43/ iLINE43w
80W @ 8 Ohms column with 4 3-inch speakers for installation

Code : H10754 (black)
Code : H10936 (white)



**iLINE43sup
iLINE43supw**
Wall bracket for iLINE43 column

Code : H10755 (black)
Code : H10937 (white)



iLINE23/ iLINE23w
40W @ 16 Ohms column with 2 3-inch speakers for installation

Code : H10752 (black)
Code : H10934 (white)



**iLINE23sup
iLINE23sup/w**
Wall bracket for iLINE23 column

Code : H10753 (black)
Code : H10935 (white)



**iLINE24sup
iLINE24supw**
Adjustable wall bracket for iLINE23 and iLINE43

Code : H10773 (black)
Code : H10945 (white)



	iLINE23	iLINE43	iLINE83	iLINE83B	iLINEsub12A	iLINEsub12P
Power	40W RMS / 80W Max	80W RMS / 160W Max	160W RMS / 320W Max	160W RMS / 320W Max	700+700 W RMS / 4Ω	400W RMS / 800W Max
Frequencies	135 Hz / 17 kHz	135 Hz / 17 kHz	135 Hz / 17 kHz	135 Hz / 17 kHz	50 Hz / 200 Hz	50 Hz / 200 Hz
Sensitivity	89 dB / 108 dB max	92 dB / 114 dB max	95 dB / 120 dB max	95 dB / 120 dB max	96 dB / 124 dB max	96 dB / 125 dB max
Impedance	16Ω	8Ω	16Ω	16Ω	8Ω	8Ω
Speakers	2x3"	4x3"	8x3"	8x3"	12"	12"
Dispersion HxV	115° / 20°	115° / 20°	115° / 20°	115° / 20°	-	-
Dimensions	110x180x148 mm	110x350x148 mm	110x690x148 mm	110x770x148 mm	350x515x490 mm	350x515x490 mm
Weight	2.2 Kg	4 Kg	7.6 Kg	7.6 Kg	23.5 Kg	22 Kg



iLINEsub12P
iLINEsub12Pw
 12-inch passive subwoofer - 400W - 8 Ohms

Code : H10763 (black)
 Code : H10944 (white)



iLINEsub12A
iLINEsub12Aw
 12-inch active subwoofer 700W + 700W with built-in DSP

Code : H10761 (black)
 Code : H10943 (white)



iLINEspace60
iLINEspace60w
 Increase height by 60cm for iLINE83B with stackable connector base

Code : H10759 (black)
 Code : H10942 (white)



iLINEbase
iLINEbasew
 Floor bracket for iLINE83B and iLINEspace60

Code : H10760 (black)
 Code : H10941 (white)



iLINEcord60
 Speakon cord/Speakon 60cm for iLINE series

Code : H10764



iLINEbox
 USB → RJ45 converter for DSP of iLINEsub12A

Code : H10762



iLINEbag
 Carrying bag for 2 iLINE 8 HP columns or 2 iLINEspace 60

Code : H10767



iLINEcov
 Protective cover for iLINE series subwoofers

Code : H10768



More information on
www.iline-series.audiophony.com

MINI LINE ARRAY HELIUM

LINE-ARRAY HELIUM SERIES

A la carte system with choice of active subwoofer and passive heads.

The set can operate in mini line array and also in 2.1 on stands thanks to the optional accessories.

The Helium system is designed to meet the needs of installers who want to benefit from line array technology while maintaining ease of use and minimum space requirements.

The quality of the mid-high grain associated with the system's directivity creates a clear and precise diffusion.



HL-10ASUB

Subwoofer for active compact line array
2 x 10 inches - 400W RMS

Code : H10520



HL-8ASUB

Subwoofer for active compact line array
2 x 8 inches - 300W RMS

Code : H10519



HL-4

Head for passive compact line array

Code : H10518



HL-BUMPER

Suspension frame for hanging the complete line array

Code : H10521



HL-FRAME

Support for hanging the HL-4 heads

Code : H10522



HL-POLE

Base for HL-FRAME

Code : H10523



	HL-4	HL-8ASUB	HL-10ASUB
Power	100W RMS - 200W max	300W RMS - 600W max	Power rating: 400W RMS - 800W max
Frequency response	150 Hz - 25 KHz	80 - 200Hz	Frequency response: 50 - 200Hz
SPL max (to 1 m)	121 dB	110 dB	SPL max. (@1m) : 114 dB
Nominal impedance	16 Ω	4 Ω	Nominal impedance: 4 Ω
Woofer	2x4"	2 x 8 inches	Woofer: 2 x 10 inches
Tweeter	1x ribbon tweeter	-	
Dispersion	Pavilion waveguides (HxV) 120° x 30° to 90° depending on the cluster angle	-	
Connectors	IN/OUT speakon	-	
Dimensions	485x135x260 mm	485 x 540 x 260 mm	485 x 540 x 310 mm
Net weight	5.2 kg	19.2 kg	29.2 kg

Amplification

Low level	-	2x 200W RMS / Class D - 8 Ω	2x 320W RMS / Class D - 4 Ω
Mid/high level	-	2x 200W RMS / class D - 8 Ω Set has a maximum of 800W	2x 200W RMS / class D - 8 Ω Set has a maximum of 1040W
Inputs	-	2x Combo XLR/Jack line level	2x Combo XLR/Jack line level
Outputs	-	2x Combo XLR/Jack line level 2x Speakon amplified for heads	2x Combo XLR/Jack line level 2x Speakon amplified for heads
Adjustments		Volume: Adjustment of the system's general level Bass: Adjustment of subwoofer level STEREO/PARALLEL selector for use in 2.1 or in Line array	

MINI LINE ARRAY CUB



"MODULARITY" IS THE KEY WORD FOR QUALIFYING THIS SYSTEM.

Whether for fixed installation or mobile use, this new concept is very attractive.

The CUBsat4 speaker can of course be used alone in a classic multi-source installation but not only here, thanks to its ingenious integrated coupling and angulation system, you can make up your system very simply and thus obtain Line Array columns for up to eight speakers.



CUBsat4
Head of 30W RMS mini line array

Code : H10663



CUBsub112
12-inch passive 300W subwoofer

Code : H10664



CUBsub208
300W RMS 8-inch 2 HP passive subwoofer

Code : H10665



CUB-Wall1
Wall bracket for CUBsat4

Code : H10730



CUB-Pole1
Foot support for CUBsat4

Code : H10731



CUB-Truss1
Suspension support for CUBsat4

Code : H10732



	CUBsat4	CUBsub112	CUBsub208
Power	30W RMS - 90W max	300W RMS - 600W max	Power rating: 300W RMS - 600W max
Frequency response	100Hz -20KHz	45Hz -2.8KHz	Frequency response: 50Hz -800Hz
Filter	2 passive channels at 3kHz	The subwoofer is not equipped with a passive filter	Filter: the subwoofer is not equipped with a passive filter
SPL max. (@1m)	91 dB	125 dB	SPL max. (@1m) : 124 dB
Nominal impedance	8 Ω for a module with integrated impedance adapter.	8 Ω	Nominal impedance: 4 Ω
Woofer	4" to neodymium	12" to 64 mm coil	Woofer: 2 x 8" to 50 mm coil
Tweeter	3 x 0.5" soft dome	-	-
Dispersion	Pavilion waveguides (HxV) 110° x 20° for a module	-	-
Cluster orientation	0°/4°/8°/12°	-	-
Connectors	for 3x 6.35 input jack and parallel and series link	Connectors: for 2x speakon and terminal block for In/Out	
Construction	cast aluminium body and mounting bracket, pin and steel hinge. Black finish	Multi-ply subwoofer and metal grating Well for coupling bar on the top and rubber feet underneath Black finish	Well for coupling bar on the top and rubber feet underneath and wall mounting plates on the side. Black finish
Dimensions	170 x 140 x 150 mm	350 x 500 x 540 mm	250 x 510 x 540 mm
Net weight	1.450 kg	20 kg	18.5 kg

THE MOJO RANGE

All in one active systems with mixer and Bluetooth® input



MOJO500LINEliberty

Active system subwoofer and column + mixer + battery + reverb with 1 Bluetooth® input

Code : H10899



MOJO500LINE

Active system subwoofer and column + mixer with 1 Bluetooth® input

Code : H10529



COV-MOJO500LINE

Protective cover for MOJO500LINE & MOJO500liberty

Code : H10867



Power rating: 200W max for the column + 300W max for subwoofer
Frequency response: 50Hz -22KHz
SPL max. (@1m) : 116 dB
Woofer: 6 x 2.75" for the column + 1x8" for the subwoofer
Dispersion : 120° x 20° (HxV)
Connectors: 2x Combo Mic/Line + 1x RCA Line et 1x 3.5 Jack Line
Bluetooth® receiver on channel 3
Adjustments: Volume by channel + general Treble/Bass
Dimensions: (80 x 80 x 830 mm) x2 for the column and support 340 x 430 x 400 mm for the subwoofer
Net weight: 3.65 kg + 10.8 kg (12,6 kg for MOJO500Liberty)



Battery Lithium PANASONIC®
DC 28.8V / 5800mAh

Power rating: 160W max (2) for the satellites + 700W max for the subwoofer
Frequency response: 50Hz -22KHz
SPL max. (@1m): 120 dB
Woofer: 4.75" for the satellite + 1x10" for the subwoofer
Tweeter: 1" compression
Dispersion: 90° x 45° (HxV)
Connectors: 1x Mic/Line Combo + 1x Guitar/microphone jack + 2x line Jack and 1x 3.5 Auxiliary Line Jack
Bluetooth® receiver on channel 3
Adjustments: Volume and effect by channel + general Treble/Bass + subwoofer volume
Multi-effects DSP Reverb Plate/ Plate2/Room/Room2/Hall/Hall2, Delay, Vocal doubler
Dimensions : [225 x 140 x 110 mm] x2 for the satellites 345 x 450 x 400 mm for the subwoofer
Net weight: 3.8 kg + 14.5 kg



MOJO1000FX

Active Subwoofer and satellites system + multi-effects DSP and a Bluetooth® input

Code : H10528



COV-MOJO1000FX

Travel bag + trolley for MOJO1000FX

Code : H10350



The set weighs less than 20 kg and takes up very little space in a car boot.

CPX SYSTEM

500W compact active audio system for all types of applications.



CPX-1510 FULL SET

500W RMS compact active audio system

Code : B00613



Power: 200W RMS for satellites column + 300W RMS for subwoofer

Frequency response: 35Hz -20KHz

SPL max. (@1m): 128 dB

Woofers: 10" for the satellite + 15" for the subwoofer

Tweeter: 1" compression

Dispersion: 90° x 70° (HxV)

Connectors: 2x XLR/line Jack input + 2x Speakon output

Adjustments: Satellite volume + subwoofer volume

Dimensions : (435x 305 x 440 mm) x2 for the satellites
440 x 600 x 590 mm for the subwoofer

Net weight: 19.5 kg + 42.8 kg

CPX-1510SAT (pair)

Two 10" satellite speakers

Code : B00611



Power: 200W

Frequency response: 100Hz -20KHz

SPL max. (@1m): 120 dB

Woofers: 10"

Tweeter: 1" compression

Dispersion: 90° x 70° (HxV)

Connectors: 2x Speakon

Dimensions: 435x 305 x 440 mm x2

Net weight: 19.5 kg



ATOM ACTIVE SPEAKERS



The ATOM series is equipped with a simple DSP and is easy to use. It allows you to adjust and configure your speaker to the required use with the touch of a button. The internal processor's different presets adapt your speaker to the current use (front, backstage, etc.) but also the current sound application (DJ, Live, Speech, etc.) without forgetting the ability to correct bass and treble +/- 10dB in order to compensate for a room's acoustic problems, for example.

Each ATOM speaker offers two inputs and one output, a large choice of connectivity in order to connect all kinds of sources at Micro or Line level.



The design of this new series provides usage flexibility and exceptional installation thanks to M10 attachment points, backstage position and an ingenious 35mm double position base allowing the speaker to be used on a stand in a straight or inclined position of 7.5° downwards.





ATOM15A
15-inch active speaker with DSP

Code : H10781



ATOM12A
12-inch active speaker with DSP

Code : H10780



ATOM10A
10-inch active speaker with DSP

Code : H10779



COV-ATOM15A
Protective cover for ATOM15A

Code : H10786



COV-ATOM12A
Protective cover for ATOM12A

Code : H10785



COV-ATOM10A
Protective cover for ATOM10A

Code : H10784



	ATOM15A	ATOM12A	ATOM10A
CODE	H10781	H10780	H10779
Total power	400 W RMS - 1600 W DYNAMIC	400 W RMS - 1600 W DYNAMIC	300 W RMS - 1200 W DYNAMIC
Amplification class	D + AB	D + AB	D + AB
Power supply	SMPS switched-mode	SMPS switched-mode	SMPS switched-mode
Protection	Limiter, thermal and short-circuit	Limiter, thermal and short-circuit	Limiter, thermal and short-circuit
Frequency response	45 Hz to 20 kHz	50 Hz to 20 KHz	60 Hz to 20 kHz
Dispersion H x V	90° x 60°	90° x 60°	90° x 60°
SPL pressure	124 dB max	123 dB max	121 dB max
Woofer	15" of 3" coil	12" of 3" coil	10" of 2.5" coil
Tweeter	1.35"	1.35"	1"
Pre-amplification	1 MIC/LINE input on XLR/Jack Combo 1 LINE Input on RCA and 3.5 Jack	1 MIC/LINE input on XLR/Jack Combo 1 LINE Input on RCA and 3.5 Jack	1 MIC/LINE input on XLR/Jack Combo 1 LINE Input on RCA and 3.5 Jack
	Line output on XLR		
	Volume adjustment per channel		
DSP	Equalisation presets: Normal, Live, Club and Speech Position presets: feet, feedback, wall Treble and bass graphic equaliser		
Dimensions (H x W x D)	730 x 425 x 415 mm	628 x 365 x 355 mm	531 x 310 x 300 mm
Net weight	20.6 kg	17.3 kg	11.3 kg

SR ACTIVE SPEAKERS

The SR series speakers have been designed for multi-purpose and intensive use. The four Presets offer effective protection and settings for all kinds of uses whether at the front, backstage, DJ set or Live.



SR15A
Amplified 2-channel speaker - Bass reflex
400 Watts RMS

Code : H10159



SR12A
Amplified 2-channel speaker - Bass reflex
400 Watts RMS

Code : H10158



SR10A
Amplified 2-channel speaker - Bass reflex
300 Watts RMS

Code : H10157



COV-SR15
Cover for SR15A speaker

Code : H10169



COV-SR12
Cover for SR12A speaker

Code : H10168



COV-SR10
Cover for SR10A speaker

Code : H10167



	SR15A	SR12A	SR10A
CODE	H10159	H10158	H10157
Total power	400 W RMS - 800 W MAX	400 W RMS - 800 W MAX	300 W RMS - 600 W MAX
Amplification class	D + AB		
Power supply	SMPS switched-mode		
Protection	Limiter, thermal and short-circuit		
Frequency response	40 Hz to 20 kHz	45 Hz to 20 KHz	55 Hz to 20 kHz
Dispersion H x V	90° x 60°	90° x 60°	90° x 60°
SPL pressure	124 dB max	123 dB max	121 dB max
Woofer	15" of 3" coil	12" of 3" coil	10" of 2.5" coil
Tweeter	1.35"	1.35"	1"
Pre-amplification	1 MIC/LINE input on XLR/Jack Combo Line output on XLR General volume adjustment Flat, Live, DJ and Vocal equalisation presets		
Dimensions (H x W x D)	410 x 450 x 710 mm	360 x 400 x 630 mm	310 x 335 x 530 mm
Net weight	21.1 kg	19.2 kg	13.4 kg

SX ACTIVE SPEAKERS



SX speakers are professional and multi-purpose. The choice of components combined with bi-amplification brings a rich and precise sound. The input connector is linked with an optional Bluetooth module that allows easy use with a smartphone or tablet.



SX15A
300W 15-inch 2-channel active speaker

Code : H10778



SX12A
300W 12-inch 2-channel active speaker

Code : H10777



SX-BT
Bluetooth module for SX speaker

Code : H10886



COV-SX15A
Protective cover for SX15A

Code : H10855



COV-SX12A
Protective cover for SX12A

Code : H10854



	SX15A	SX12A
CODE	H10778	H10777
Total power	300 W RMS - 600 W MAX	300 W RMS - 600 W MAX
Amplification class	D	D
Power supply	SMPS switched-mode	SMPS switched-mode
Protection	Limiter, thermal and short-circuit	Limiter, thermal and short-circuit
Frequency response	50 Hz to 20 kHz	55 Hz to 20 kHz
Dispersion H x V	90° x 60°	90° x 60°
SPL pressure	121 dB max	120 dB max
Woofers	15" of 2" coil	12" of 2" coil
Tweeter	1.35"	
Pre-amplification	1 MIC/LINE Input on Combo and RCA Line output on XLR General volume adjustment "Contour" Preset	
Optional module	Bluetooth® receiver 4.0 Pairing, Play/Pause, Skip, Vol buttons	
Dimensions (H x W x D)	630 x 390 x 370 mm	600 x 380 x 340 mm
Net weight	14.5 kg	13.2 kg

PSA ACTIVE SPEAKERS



- Bi-Amping technology with separate amplifiers
- Active two-channel filter
- 2 balanced MIC inputs + 1 LINE input with level adjustment
- Balanced LINE output
- Adjustment buttons for treble + bass + main volume



PSA-15
15" active professional speaker

Code : B00617



PSA-12
12" active professional speaker

Code : B00616



PSA-10
10" active professional speaker

Code : B00629



PSA-08
8" active professional speaker

Code : B00628



TOURING BAG - PS-15/PSA-15
Cover for PS-15/PSA-15

Code : B00597



TOURING BAG - PS-12/PSA-12
Cover for PS-12, PSA-12, PPA-121

Code : B00596



	PSA-15	PSA-12	PSA-10	PSA-08
Code	B00617	B00616	B00629	B00628
Total RMS power	245+55 W	165+35 W	130+30 W	120 W
Frequency response	40 Hz to 20 kHz	45 Hz to 20 KHz	60 Hz to 20 KHz	70 Hz to 20 KHz
Dispersion H x V	90° x 60°	90° x 60°	90° x 60°	90° x 60°
Woofer	15"	12"	10 inch	08 inch
Tweeter	1.75"	1.35"	1.35 inch	1 inch
Pre-amplification	1 MIC Input on XLR and RCA 1 LINE Input on RCA and XLR Line Output on XLR and JACK General volume and Mic and Line volume adjustment General Treble and Bass adjustment			
Dimensions (H x W x D)	680 x 470 x 400 mm	588 x 431 x 310 mm	500 x 355 x 270 mm	402 x 294 x 220 mm
Net weight	23.3 kg	17 kg	11.6 kg	8 kg

MONITORS



ACUTE08/AMP
150W active 8" moulded speaker

Code : H8738



SUP-AC08N0
ACUTE08 monitor hanging bracket - black

Code : H8738



	ACUTE08/AMP
CODE	H8738
Total power	150 W RMS - 300 W MAX
Amplification class	D
Power supply	Toroidal
Protection	Limiter, thermal and short-circuit
Frequency response	70 Hz to 18 kHz
Dispersion H x V	90° x 60°
SPL pressure	117 dB max
Woofers	8" of 2" coil
Tweeter	1"
Pre-amplification	1 MIC Input on Jack 1 Input LINE on XLR Line output on XLR Mic and Line volume adjustment
Dimensions (H x W x D)	435 x 255 x 245 mm
Net weight	9.5 kg



AM50
Set of active 5" studio monitors, equipped with a 2 x 35 Wrms amp

Code : B00623



	AM50
CODE	B00623
Total power	2x35 W RMS
Frequency response	65 Hz to 20 kHz
Woofers	5" Kevlar
Tweeter	3/4" soft dome
Pre-amplification	1 LINE Input on 3.5 Jack Line Output on RCA Amplified left output on terminal block General volume adjustment
Dimensions (H x W x D)	180 x 258 x 209 mm
Net weight	6.3 kg

SC PASSIVE SPEAKERS

- Passive speakers for “high-end” performance
- Designed, developed and manufactured in Europe
- European components assembled in Hi-end coaxial speakers
- High quality Baltic birch plywood and polyurethane with coating of “Chemline” (USA) anti-scratch paint
- Very powerful and excellent performance



SC-15
15" 2-channel 400 WRMS speaker

Code : B09183



SC-12
12" 2-channel 400 WRMS speaker

Code : B09182



SC-08
8" 2-channel 300 WRMS speaker

Code : B09181



NEW



SC-05
SC-05-WHITE
5" 2-channel 250 WRMS speaker

Code : B09180
Code : B08609 (white)



SC-15	SC-12	SC-08	SC-05
2-channel passive filter	2-channel passive filter	2-channel passive filter	2-channel passive filter
15" low frequency speaker with ferrite + 1.45" tweeter (1" coil)	12" low frequency speaker with ferrite + 1.45" tweeter (1" coil)	8" low frequency speaker with ferrite + 1.45" tweeter (1" coil)	5" low frequency speaker with ferrite + 1.75" tweeter (0.75" coil)
3 Speakons	3 Speakons	Speakon in/out 4-pin	Speakon in/out 4-pin + Euroblock 4-pin connector
Switch selection + -1 or + -2	Switch selection + -1 or + -2	Switch selection + -1 or + -2	Switch selection + -1 or + -2
Enclosure in multi-ply Finnish birch	Enclosure in multi-ply Finnish birch	Enclosure in multi-ply Finnish birch	OMEGA® fastening hook
Resistant textured black paint	Resistant textured black paint	Resistant textured black paint	Can be attached to a microphone stand using the U-bracket
Max SPL: 128dB	Max SPL: 128dB	Max SPL: 123dB	Max SPL: 119dB
Bandwidth: 54-19.000Hz (-3dB)	Bandwidth: 60-20.000Hz (-3dB)	Bandwidth: 70-20.000Hz (-3dB)	Bandwidth: 120-21.000Hz (-3dB)
Polarity: 60° x 40°	Polarity: 60° x 40°	Polarity: 90° cone	Polarity: 70° cone
Power rating: 400 W AES (recommend amplifier: 800W RMS)	Power rating: 400 W AES (recommend amplifier: 800W RMS)	Power rating: 300 W AES (recommend amplifier: 600W RMS)	Power rating: 250 W AES (recommend amplifier: 500W RMS)
Impedance: 8 Ω	Impedance: 8 Ω	Impedance: 8 Ω	Impedance: 16 Ω
Dimension : 368x580x447 mm	Size: 351x540x410 mm	Dimensions: 254x420x250 mm	Size: 165x165x165 mm
Weight: 19 kg	Weight: 16 kg	Weight: 8 kg	Weight: 4 kg

Accessories for attachments and flight cases available, see accessories section

VIBE PASSIVE SPEAKERS



- Ideal for fixed installations in bars, clubs
- Very solid MDF enclosure
- Covered with metal grid and with acoustic foam inside
- Fibreglass pavilion



VIBE30 MK2
Pro. speaker : 2x 15" - 800Wrms / 4 Ω

Code : B00693



VIBE15 MK2
Pro. speaker : 15" - 350Wrms / 8 Ω

Code : B00692



VIBE12MK2
Pro. speaker : 12" - 250Wrms / 8 Ω

Code : B00691



VIBE10MK2
Pro. speaker : 8" - 150Wrms / 8 Ω

Code : B00689



VIBE8 MK2
Pro. speaker : 2x 15" - 800Wrms / 4 Ω

Code : B00689



CLS-8 II
8" compact high power speaker

Code : B00630



TOURING BAG
Travel bag for Vibe 30

Code : B00593

TOURING BAG
Travel bag for Vibe 15

Code : B00592

TOURING BAG
Travel bag for Vibe 12

Code : B00591



VIBE30 MK2	VIBE15 MK2	VIBE12 MK2	VIBE10 MK2	VIBE8 MK2	CLS-8 II
Power rating: 800WRMS	Power rating: 350WRMS	Power rating: 250WRMS	Power rating: 200WRMS	Power rating: 150WRMS	Power rating: 200 WRMS
Impedance: 4 Ω	Impedance: 8 Ω	Impedance: 8 Ω	Impedance: 8 Ω	Impedance: 8 Ω	Impedance: 8 Ω
Max performance [dB] : 131	Max performance [dB] : 125	Max performance [dB] : 122	Max performance [dB] : 120	Max performance [dB] : 120	-
Bandwidth (Hz) : 40-20000	Bandwidth (Hz) : 45-20000	Bandwidth (Hz) : 55-20000	Bandwidth (Hz) : 65-20000	Bandwidth (Hz) : 65-20000	Bandwidth (Hz) : 70-20,000
Dimensions (cm) : 116 x 49 x 50.3	Dimensions (cm) : 76 x 47 x 43.5	Dimensions (cm) : 62 x 38.2 x 34.5	Dimensions (cm) : 33 x 51 x 30.2	Dimensions (cm) : 46.5 x 27.7 x 27	Dimensions (cm) : 46.0 x 28.6 x 27.6
Weight (kg) : 50	Weight (kg) : 29	Weight (kg) : 20	Weight (kg) : 15	Weight (kg) : 12	Weight (kg) : 13

SR & ACUTE PASSIVE SPEAKERS



SR15P
15" 300W plastic moulded passive speaker
- GOA series

Code : H10270

SR12P
12" 300W plastic moulded passive speaker
- GOA series

Code : H10269



SR10P
10" 200W plastic moulded passive speaker
- GOA series

Code : H10268



ACUTE-08NO
8" passive plastic speaker

Code : H9595



ACUTE-08WH
8" passive plastic speaker white

Code : H9596



SUP-AC08NO
ACUTE08 monitor hanging bracket - black

Code : H9598



SUP-AC08WH
ACUTE08 monitor hanging bracket - white

Code : H9599



SR15P	SR12P	SR10P	ACUTE-08
Output power: 350W RMS / 700W max.	Output power: 350W RMS / 700W max.	Output power: 250W RMS / 500W max.	Output power: 150 W RMS
Frequency response: 45 Hz - 20 KHz	Frequency response: 55 Hz - 20 KHz	Frequency response: 65 Hz - 20 KHz	Frequency response: 70 Hz - 18 KHz
Impedance: 8 Ω	Impedance: 8 Ω	Impedance: 8 Ω	Impedance: 8 Ω
SPL: 96 dB max.	SPL: 96 dB max.	SPL: 94 dB max.	SPL: 94 dB max.
Dimensions: 410 x 450 x 710 mm	Dimensions: 360 x 400 x 630 mm	Dimensions: 310 x 335 x 530 mm	Dimensions: 435 x 255 x 245 mm
Net weight: 19.2 Kg	Net weight: 17.8 Kg	Net weight: 11.8 Kg	Net weight: 8 kg

PS PASSIVE SPEAKERS



PS-15
15" passive 300Wrms/8Ω speaker

Code : B00610





PS-12
12" passive 200Wrms/8Ω speaker

Code : B00609



PS-10
10" passive 160Wrms/8Ω speaker

Code : B00627



PS-08
8" passive 120Wrms/8Ω speaker

Code : B00626



TOURING BAG - PS-15/PSA-15
Cover for PS-15/PSA-15

Code : B00597





TOURING BAG - PS-12/PSA-12
Cover for PS-12, PSA-12, PPA-121

Code : B00596

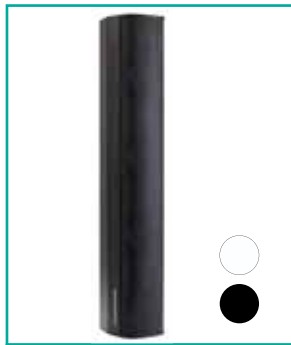

PS-15	PS-12	PS-10	PS-08
Output power: 300W RMS / 600W max.	Output power: 200W RMS / 400W max.	Output power: 160W RMS / 320W max.	Output power: 120 W RMS / 240W max.
Frequency response: 45 Hz - 20 KHz	Frequency response: 45 Hz - 20 KHz	Frequency response: 60 Hz - 20 KHz	Frequency response: 70 Hz - 20 KHz
Impedance: 8 Ω	Impedance: 8 Ω	Impedance: 8 Ω	Impedance: 8 Ω
Dimensions: 680 x 470 x 400 mm	Dimensions: 580 x 420 x 310 mm	Dimensions: 500 x 355 x 270 mm	Dimensions: 402 x 290 x 220 mm
Net weight: 19.8 Kg	Net weight: 13.2 Kg	Net weight: 10.3 Kg	Net weight: 6.6 kg

PASSIVE SPEAKERS



iLINE83/iLINE83w
160W @ 16 Ohms column with 8 3-inch speakers for installation

Code : H10756 (black)
Code : H10938 (white)



**iLINE83sup
iLINE83sup/w**
Wall bracket for iLINE83 column

Code : H10757 (black)
Code : H10940 (white)



iLINE43/ iLINE43w
80W @ 8 Ohms column with 4 3-inch speakers for installation

Code : H10754 (black)
Code : H10936 (white)



**iLINE43sup
iLINE43sup/w**
Wall bracket for iLINE43 column

Code : H10755 (black)
Code : H10937 (white)



CUBsat4
Head of 30W RMS mini line array

Code : H10663



iLINE23/ iLINE23w
40W @ 16 Ohms column with 2 3-inch speakers for installation

Code : H10752 (black)
Code : H10934 (white)



**iLINE23sup
iLINE23sup/w**
Wall bracket for iLINE23 column

Code : H10753 (black)
Code : H10935 (white)



**iLINE24sup
iLINE24sup/w**
Adjustable wall bracket for iLINE23 and iLINE43

Code : H10773 (black)
Code : H10945 (white)



HL-4
2x4" mini line array head + TWT ribbon

Code : H10518



	iLINE23	iLINE43	iLINE83	CUBSAT4	HL-4
Power	40W RMS / 80W MAX	80W RMS / 160W MAX	160W RMS / 320W MAX	300W RMS - 600W max	100W RMS - 200W max
Response Response	135 HZ / 17 KHZ	135 HZ / 17 KHZ	135 HZ / 17 KHZ	50Hz - 800Hz	150 Hz - 25 KHz
Sensitivity	89 DB / 108 DB MAX	92 DB / 114 DB MAX	95 DB / 120 DB MAX	124 dB	121 dB
Impedance	16Ω	8Ω	16Ω	4 Ω	16 Ω
Speakers	2X3"	4X3"	8X3"	1X4" + 3X0.5"	2X4" + RIBBON
Dispersion HxV	115° / 20°	115° / 20°	115° / 20°	110° / 20°	120° x 30° to 90°
Dimensions	110X180X148 mm	110X350X148 mm	110X690X148 mm	250 x 510 x 540 mm	485x135x260 mm
Weight	2.2 kg	4 kg	7.6 kg	18.5 kg	5.2 kg

S SERIES PASSIVE SPEAKERS



S6
Passive 6.5P 80W RMS monitor - black

Code : H9689



S6W
Passive 6.5P 80W RMS monitor - white

Code : H9690



S8
Passive 8P 120W RMS monitor - black

Code : H9691

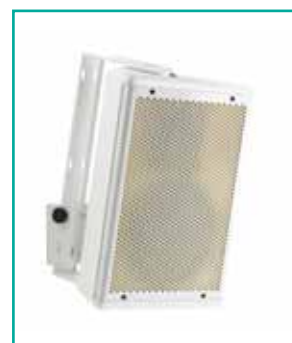

S8W
Passive 8P 120W RMS monitor - white

Code : H9692



S10
Passive 10P 250W RMS monitor - black

Code : H9693



S10W
Passive 10P 250W RMS monitor - white

Code : H9694



ISX-10 (pair)
Compact 2-channel trapezoidal speaker
Price for the pair

Code : B00619



ISX-5 (pair)
Compact 2-channel trapezoidal speaker
Price for the pair

Code : B00618



Hanging brackets:

SUPS6	Hanging bracket for S6 satellite - black	H9705
SUPS6w	Hanging bracket for S6 satellite	H9706
SUPS8	Hanging bracket for S8 satellite - black	H9707
SUPS8w	Hanging bracket for S8 satellite - white	H9708
SUPS10	Hanging bracket for S10 satellite - black	H9709
SUPS10w	Hanging bracket for S10 satellite - white	H9710

	S6	S8	S10	ISX-10 (UNIT)	ISX-5 (UNIT)
Power	100W RMS / 200W MAX	150W RMS / 300W MAX	250W RMS / 500W MAX	160 W RMS	80 W RMS
Frequency response	80 HZ / 20 KHZ	80 HZ / 19 KHZ	75 HZ / 19 KHZ	100 Hz - 20 Khz	120 Hz - 20 Khz
Sensitivity	93 DB / 118 DB MAX	94 DB / 121 DB MAX	96 DB / 126 DB MAX	116	110
Impedance	8Ω	8Ω	8Ω	8Ω	16Ω
Speakers	6.5"	8"	10"	2X5"	5 INCH
Dispersion HxV	90° / 60°	50-100° / 55°	50-100° / 55°	-	-
Dimensions	222 x 365 x 205 mm	280 x 420 x 233 mm	320 x 530 x 280 mm	400 X 200 X 180 mm	285 X 200 X 180 mm
Weight	6.5 kg	10 kg	14.5 kg	15.5 kg	10.5 kg

SUBWOOFERS



ATOM18ASUB
18-inch active subwoofers with DSP

Code : H10783



ATOM15ASUB
15-inch active subwoofers with DSP

Code : H10782



SRSUB18A
18" active 1200W subwoofer with adjustable filter

Code : H10713



SRSUB15A
15" active 500W subwoofer with adjustable filter

Code : H10349



COV-ATOM18ASUB
Protective cover for ATOM18ASUB

Code : H10788



COV-ATOM15ASUB
Protective cover for ATOM15ASUB

Code : H10787



COV-SRSUB18A
Protective cover for SRSUB18A subwoofer

Code : H10887



COV-SRSUB15A
Protective cover for SRSUB15A subwoofer

Code : H10351



	ATOM18ASUB	ATOM15ASUB	SRSUB18A	SRSUB15A
CODE	H10783	H10782	H10713	H10349
Total power	600 W RMS - 2000 W DYNAMIC	600 W RMS - 2000 W DYNAMIC	600 W RMS - 1200 MAX	500W RMS / 1000W max
Amplification class	D	D	D	D
Power supply	SMPS switched-mode	SMPS switched-mode	SMPS switched-mode	SMPS switched-mode
Protection	Limiter, thermal and short-circuit	Limiter, thermal and short-circuit	Limiter, thermal and short-circuit	Limiter, thermal and short-circuit
Frequency response	35 Hz to 150 Hz	45 Hz to 160 KHz	60 Hz to 150 KHz	60 Hz to 150 KHz
SPL pressure	127 dB max	126 dB max	127 dB max	125 dB max
Woofer	18" of 4" coil	15" of 4" coil	18" of 4" coil	15" of 4" coil
Pre-amplification	Line Inputs for XLR/Jack Combo	Line Inputs for XLR/Jack Combo	Line Inputs for XLR/Jack Combo	Line Inputs for XLR/Jack Combo
	Line Outputs on XLR	Line Outputs on XLR	Line Outputs on XLR	Line Outputs on XLR
	Volume adjustment	Volume adjustment	Volume adjustment 60 to 150 Hz adjustable filter	Volume adjustment 60 to 150 Hz adjustable filter
DSP	Equalisation presets: Normal, Enforce Position presets: Normal, Cardioid, Endfire Extension from 0 to 15 m Normal or inverted polarity Filtering: 60/80/100/120/150 Hz + high output for ATOM 10A/12A/15A		-	-
Dimensions (H x W x D)	662 x 510 x 615 mm	612 x 430 x 595 mm	770 x 680 x 560 mm	702 x 560 x 472 mm
Net weight	38 kg	30.3 kg	39 kg	34 kg



ATOM-WHEELS

4-wheel kit for ATOMSUB subwoofer

Code : H10875



iLINEsub12P

12" passive subwoofer- 400W - 8 Ω

Code : H10763



iLINEsub12A

12" active subwoofer 700W + 700W with built-in DSP

Code : H10761



iLINEbox

USB → RJ45 converter for DSP of iLINEsub12A

Code : H10762



Power rating: 400 W RMS/800 W max
Frequency response: 50 Hz - 200 Hz
Axial sensitivity (1W/1m) : 96 dB
Max. SPL: 125 dB
Nominal impedance: 8 Ω
Speakers: 12 inch
Dimensions: 350 x 515 x 490 mm
Net weight: 22 Kg

Connectors:
- Input: Speakon 4 points output
- 1+/1- : Broadband output
- 2+/2- : Bass output:

Power rating: 700W / 4Ω + 700W / 4Ω
Frequency response: 50 Hz - 200 Hz
Axial sensitivity (1W/1m) : 96 dB
Max. SPL: 124 dB
Nominal impedance: 8 Ω
Loudspeaker: 12 inch
Size: 350 x 515 x 490 mm
Net weight: 23.5 Kg

Amplification:
- Total available power 700+700 W RMS / 4Ω :
- Broadband outputs: 700W RMS / 4Ω .
- Bass outputs: 350W RMS / 8Ω. + 350W RMS / 8Ω internal

DSP : 28/56 bit, 50 MIPS
Setting the system via the supplied software
Connectors:
- RJ45
- USB B
Dimensions: 56 x 58 x 23 mm
Weight: 65 g

Delivered with USB A/USB B cord



iLINEcov

Protective cover for iLINE series subwoofers

Code : H10768



HL-8ASUB

Subwoofer for active compact line array 2 x 8" - 300W RMS

Code : H10519



HL-10ASUB

Subwoofer for active compact line array 2 x 10" - 400W RMS

Code : H10520



HL-BUMPER

Suspension frame for hanging the complete line array

Code : H10521



General features
Power rating: 300W RMS - 600W max
Frequency response: 80 - 200Hz
SPL max. (@1m) : 110 dB
Nominal impedance: 4 Ω
Woofer: 2 x 8 inches
Dimensions: 485 x 540 x 260 mm
Net weight: 19.2 kg

Amplification Class D
Low level: 2 x 200W RMS / 8 Ω
Mid/high level 2 x 200W RMS / 8 Ω

General features
Power rating: 400W RMS - 800W max
Frequency response: 50 - 200Hz
SPL max. (@1m) : 114 dB
Nominal impedance: 4 Ω
Woofer: 2 x 10 inches
Dimensions: 485 x 540 x 310 mm
Net weight: 29.2 kg

Amplification Class D
Low level: 2 x 320W RMS / 8 Ω
Mid/high level 2 x 200W RMS / 8 Ω

Can hang a maximum of 8 heads and 2 subwoofers
Maximum weight supported: 110 kg

SUBWOOFERS

- Passive subwoofers for high-end performance
- Designed, developed and manufactured in Europe
- FAITAL brand components with Neodymium magnet, high quality Baltic birch plywood and coating of polyurethane "Chemline" (USA) anti-scratch paint
- 2400W AES



	SQ-218	SQ-215	SQ-212
CODE	B09189	B09188	B09187
Total power	2400 W AES	2400 W AES	2400 W AES
Impedance	4 Ω	4 Ω	4 Ω
Bass frequency limit	25 Hz	30 Hz	35 Hz
SPL pressure	102 dB 1W/1m - 146 dB max	101 dB 1W/1m - 145 dB max	101 dB 1W/1m - 135 dB max
Woofers	2x18" Faital	2x15" Faital	2x12" Faital
Dimensions (H x W x D)	1180 x 800 x 560 mm	800 x 800 x 540 mm	600 x 600 x 400 mm
Net weight	80 kg	60 kg	38.2 kg

More information on: www.synq-audio.com



The SUB-OCTAVE MK2 2.1 SUB-OCTAVE amplified iLine column or any type of speaker like traditional S8 speaker. These many built-in settings allow it to be used in all configurations.



NEW



SUB-OCTAVE MK2
Subwoofer 15" 1000W/80hms + 2x450W/4ohms

Code : H10980



Frequency response : 40 – 20 000 Hz
Sensibility (1 W@1m) : 99 dB
SPL max (@1m) : 130 dB
Boomer : 15 inches 100 mm voice coil

AMPLIFIER :
Sub : 1 x 900 W RMS 8 Ohms
Mid/high : 2 x 450 W RMS 4 Ohms
2 x 250 W RMS 8 Ohms
Inputs : 2 x XLR/Jack combo line in
1 x Bluetooth®
Outputs : 2 x XLR line level
2 x Speakon powered Mid/High out
Volumes : Master level

SUB LEVEL :
Sub filter : 40 to 200 Hz X-over with Invert switch
Mid/High filter : Full range / 80 Hz / 120 Hz switch
Equalizer : Low +/- 10dB @ 80 Hz
Mid +/- 10dB @ 2,5 kHz
High +/- 10dB @ 12 kHz
Display : Limit / Signal / ON LEDs
Dimensions : 580 x 405 x 550 mm
Weight : 35 kg

MTsub12A
400W amplified subwoofer - Bass reflex

Code : H10078



Total power of amp: 400 W RMS / 800 W Max :
SMPS switched mode power supply
Frequency response: 50 Hz to 180 Hz
SPL acoustic pressure: 124 dB max
Woofer : 12", 4 Ω, 400 W RMS
1 stereo line input on XLR and RCA
1 stereo line output on XLR
Volume adjustment
Adjusting the low cut-off frequency of the sub: from 80 to 180 Hz
Low cut filter (OFF-80-125) for satellite output
Phase correction 0-180
Protections: CC, thermal and limiter
Dimensions: 469 x 489 x 360 mm
Net weight: 21.6 kg



CPX-1510SUB
15" active subwoofer with 2x100W active output

Code : B00612



Power rating: 300 + 200 RMS
Frequency response: 35 - 20000Hz
SPL max. (@1m) : 128 dB
Woofer: 15 inch
Dimensions: 440 x 600 x 590 mm
Net weight: 42.8 kg

Amplification
Low level: 1x 300W RMS
Mid/high level: 2x 100W RMS
Adjustments: Satellite volume + subwoofer volume



RS-218B
Subwoofer equipped with two 18" high power and compact speakers.

Code : B00636



Nominal RMS power: 2x 600W
Nominal PEAK power: 2x 1200W
Nominal impedance: 2x 8Ω
Parallel mode:
Nominal RMS power: 1x 1200W
Nominal PEAK power: 1x 2400W
Nominal impedance: 1x 4Ω
Frequency response: 35 - 300Hz
Sensitivity (1W/1m): 104dB
Max. SPL: 138dB
Dimensions (WxDxH): 1200 x 700 x 565 mm
Weight (net): 84 kg



Ex15S
15" 600W passive subwoofer

Code : H9701



Power: 600 W RMS / 1200 W peak
Frequency response (-3 dB) : 50 Hz - 200 Hz
Impedance: 8 Ω
Sensitivity 1 W/1 m : 99 dB / 132 dB SPL
Woofer : 15" aluminium frame with 100 mm coil
Connectors: Speakon x 2 (1+1- full range)
Dimensions (H x W x D) : 450 x 560 x 635
Net weight: 31 kg

SUBWOOFERS



VIBE18-SUB Mk2

Pro subwoofer: 18" - 600Wrms / 8Ω

Code : B00695



Power rating: 600W RMS
Frequency response: 30Hz -250 Hz
SPL max. (Ø1m) : 131 dB
Nominal impedance: 8 Ω
Woofer: 18" aluminium
Connectors: 2 speakon
Dimensions: 590 x 736 x 756 mm
Net weight: 57 kg



VIBE15-SUB Mk2

Pro subwoofer: 15" - 400Wrms / 8Ω

Code : B00694



Power rating: 400W RMS
Frequency response: 40Hz -300 Hz
SPL max. (Ø1m) : 124 dB
Nominal impedance: 8 Ω
Woofer: 15" aluminium
Connectors: 2 speakon
Dimensions: 440 x 595 x 605 mm
Net weight: 32.5 kg



TOURING BAG - Vibe 15 SUB

Travel bag for Vibe 15 SUB

Code : B00594



High-performance protective cover for Series Vibe models.



TOURING BAG - Vibe 18 SUB

Travel bag for Vibe 18 SUB

Code : B00595



High-performance protective cover for Series Vibe models.



CUBsub112

12" 300W passive subwoofer

Code : H10664



Power rating: 300W RMS - 600W max
Frequency response: 45Hz -2.8KHz
Filter: the subwoofer is not equipped with a passive filter
SPL max. (Ø1m) : 125 dB
Nominal impedance: 8 Ω
Woofer: 12" to 64 mm coil
Connectors: 2 speakon and terminal block for In/Out
Dimensions: 350 x 500 x 540 mm
Net weight: 20 kg



CUBsub208

Passive subwoofer to 2 HP from 8" 300W RMS

Code : H10665



Power rating: 300W RMS - 600W max
Frequency response: 50Hz -800Hz
Filter: The subwoofer is not equipped with a passive filter
SPL max. (Ø1m) : 124 dB
Nominal impedance: 4 Ω
Woofer: 2 x 8" to 50 mm coil
Connectors: 2 x speakon and terminal block for In/Out
Dimensions: 250 x 510 x 540 mm
Net weight: 18.5 kg



CB-210

Subwoofer 2 x 10" - 300W

Code : H9256



Power handling: 300 W RMS / 600 W max.
Frequency response (+/-3 dB) : 48 - 160 Hz
Sensitivity (1 W/1 m) : 96 dB
Max. SPL: 127 dB
Loudspeaker: 2 x 26 cm - 50 mm coil
Nominal impedance: 4 Ω
Connectors: 2 x Speakon NL4
1 base for coupling bar
Dimensions (H x W x D) : 400 x 650 x 445 mm
Weight: 32 kg



I-SUB 210

SYNQ high power subwoofer 2 x 10" with very compact design.

Code : B00642



Power rating: 500 W RMS
Frequency response: 50Hz -200Hz
SPL 1w/1m : 98 dB
Nominal impedance: 8 Ω
Woofer: 2x10"
Connectors: 2 x speakon
Dimensions: 600 x 350 x 410 mm
Net weight: 26 kg



ISX-15S

Subwoofer 15: 2x350Wrms / 2x 4 ohms

Code : B00620



SQ-212 DOLLY

Customised SYNQ trolley for fast and safe SQ subwoofer transport

Code : B09190



SQ-215 DOLLY

Customised SYNQ trolley for fast and safe SQ subwoofer transport

Code : B09191



SQ-218 DOLLY

Customised SYNQ trolley for fast and safe SQ subwoofer transport

Code : B09192



WHEELSET

SYNQ set of wheels for subwoofer Synq (RS and CLS series)

Code : B00637



Custom trolley for fast and safe transportation of SQ subwoofers.
Thanks to a special robust mechanism, the trolley adapts easily to the front of the subwoofer to protect it.

Set of wheels for the subwoofers Synq (RS and CLS series)

AMPLIFIERS

The heart of playback, performance and durability, exceptional sound quality. Professional and consumer solutions.

			
<p>DSPA-1500 2 x 440W @ 8Ω, 2 x 750W @ 4Ω, 2 x 1200W @ 2Ω</p> <p>Code : B00275</p> 	<p>DSPA-1000 2 x 300W @ 8Ω, 2 x 500W @ 4Ω, 2 x 750W @ 2Ω</p> <p>Code : B00274</p> 	<p>SMi1500 Amplifier with switched-mode power supply 2 x 750W @ 4Ω</p> <p>Code : H9829</p> 	<p>SMi1000 Amplifier with switched-mode power supply 2 x 500W @ 4Ω</p> <p>Code : H9828</p> 
			
<p>SMi600 Amplifier with switched-mode power supply 2 x 300W @ 4Ω</p> <p>Code : H9827</p> 	<p>C3-1800 2x 450Wrms + 900Wrms subwoofer @ 4Ω</p> <p>Code : B00262</p> 		

	DSPA-1500	DSPA-1000	SMi1500	SMi1000	SMi600	C3-1800
Power	<ul style="list-style-type: none"> - RMS stereo 4Ω: 2 x 750W 4 Ω: 2 x 440 W 2 Ω: 2 x 1200 W <ul style="list-style-type: none"> - Bridged mono 8 Ω: 1 x 1500 W 4Ω: 1 x 2400 W 	<ul style="list-style-type: none"> - RMS stereo 4Ω: 2 x 500 W 8 Ω: 2 x 300 W 2 Ω: 2 x 750W <ul style="list-style-type: none"> - Bridged mono 8 Ω: 1 x 1000 W 4Ω: 1 x 1500 W 	<ul style="list-style-type: none"> - RMS stereo 4Ω: 2 x 750W 8 Ω: 2 x 450 W 2 Ω: 2 x 1000 W <ul style="list-style-type: none"> - Bridged mono 8 Ω: 1 x 1500 W 4Ω: 1 x 2000 W 	<ul style="list-style-type: none"> - RMS stereo 4Ω: 2 x 500W 8 Ω: 2 x 310 W 2 Ω: 2 x 600 W <ul style="list-style-type: none"> - Bridged mono 8 Ω: 1 x 1000 W 4Ω: 1 x 1200 W 	<ul style="list-style-type: none"> - RMS stereo 4Ω: 2 x 300 W 8 Ω: 2 x 200 W 2 Ω: 2 x 450 W <ul style="list-style-type: none"> - Bridged mono 8 Ω: 1 x 600 W 4Ω: 1 x 900 W 	<ul style="list-style-type: none"> - RMS stereo 4Ω: 2 x 450W RMS 8 Ω: 2 x 300 W RMS <ul style="list-style-type: none"> - Subwoofer: 4Ω: 1 x 900 W RMS 8 Ω: 1 x 600 W RMS
Type of amplification	Class D	Class D	Class 2H	Class AB	Class AB	Class AB
Damping factor	200	200	200	200	100	500
Cooling	Front-to-back regulated ventilation					
Connectors	<ul style="list-style-type: none"> - Input: Balanced combo (XLR + TRS jack) connector - Output: Screw-on terminals + 4-pole Speakon® 		<ul style="list-style-type: none"> - Input: XLR + Jack + RCA connectors - Output: Screw-on terminals + 4-pole Speakon® 		<ul style="list-style-type: none"> - Input: XLR connectors - Output: 4-Pole Speakon® 	
Protections	<ul style="list-style-type: none"> - Against short-circuits - Signal and current limiter - Against voltage deviations - Thermal protection 		<ul style="list-style-type: none"> - Against short-circuits - Current limiter - Against voltage deviations - Immunity to radio frequencies - Thermal protection and regulation 		<ul style="list-style-type: none"> - Limiter - Against short-circuits - Against overloads and DC - Thermal protection and regulation 	
DSP	HPF, LPF, PEQ, Q, Limiter, Delays, filters.					
Dimensions (L x W x H)	19" x 2U (482 x 88 x 280mm)		19" x 2 U: 483 x 89 x 395mm			19" x 2 U: 483 x 89 x 473 mm
Weight	5.2kg	4.9 kg	9.2 kg	6.9 kg	6 kg	24 kg



DIGIT 3K6
2 x 1,800Wrms / 4Ω, class D

Code : B00267



DIGIT 2K2
2 x 1,100Wrms / 4Ω, class D

Code : B00266



DIGIT 1K0
2 x 540Wrms / 4Ω, class D

Code : B00268



	DIGIT 3K6	DIGIT 2K2	DIGIT 1K0
Power	<ul style="list-style-type: none"> - RMS stereo 4Ω : 2 x 1800 W 8 Ω : 2 x 1050 W - Bridged mono 8 Ω : 1 x 3600W 	<ul style="list-style-type: none"> - RMS stereo 4Ω : 2 x 1100 W 8 Ω : 2 x 650 W - Bridged mono 8 Ω : 1 x 2200W 	<ul style="list-style-type: none"> - RMS stereo 4Ω : 2 x 540 W 8 Ω : 2 x 300 W - Bridged mono 8 Ω : 1 x 1080W
Type of amplification	Class D	Class D	Class D
Damping factor	300	300	280
Cooling	Front-to-back regulated ventilation		
Connectors	<ul style="list-style-type: none"> - Input: XLR/Jack combo connectors - Output: 4-Pole Speakon® 		
Protections	<ul style="list-style-type: none"> - Against short-circuits - Signal + current limiter - Against overloads - Thermal protection - AC, VHF protection 		
Dimensions [L x W x H]	19" x 1 U: 483 x 44 x 301 mm		19" x 1 U: 483 x 44 x 301 mm
Weight	5.6 kg	5.5 kg	3.3 kg

AMPLIFIERS

			
AMP 400.2 2 x 400Wrms / 4Ω	AMP 200.2 2 x 200Wrms / 4Ω	AMP 100.2 2 x 100Wrms / 4Ω	AMP 150.4 4 x 150W @ 4Ω
Code : B00272	Code : B00271	Code : B00270	Code : B00273
			

		
Ti500 Class D Amplifier 1 unit 2 x 250W @ 4Ω or 1 x 500W @ 8Ω	Ti300 Class D Amplifier 1 unit 2 x 150W @ 4Ω or 1 x 300W @ 8Ω	Ti154 Class D Amplifier 1 unit 4 x 150W @ 4Ω or 2 x 300W @ 8Ω
Code : H9673	Code : H9672	Code : H10412
		

	AMP 400.2	AMP 200.2	AMP 100.2	AMP 150.4	Ti500	Ti300	Ti154
Power	- RMS stereo 4Ω: 2 x 400 W 8 Ω : 2 x 250 W - Bridged mono 8 Ω : 1 x 800W	- RMS stereo 4Ω: 2 x 200 W 8 Ω : 2 x 130 W - Bridged mono 8 Ω : 1 x 400W	- RMS stereo 4Ω: 2 x 100 W 8 Ω : 2 x 70 W - Bridged mono 8 Ω : 1 x 200W	4Ω: 4 x 150 W RMS 8 Ω : 4 x 80 W RMS	- RMS stereo 4Ω: 2 x 250 W 8 Ω : 2 x 130 W - Bridged mono 8 Ω : 1 x 500W	- RMS stereo 4Ω: 2 x 150 W 8 Ω : 2 x 80 W - Bridged mono 8 Ω : 1 x 300W	4Ω: 4 x 150 W RMS 8 Ω : 4 x 80 W RMS
Type of amplification	Class D						
Cooling	Front-to-back regulated ventilation						
Connectors	- Input: XLR connectors - Output: 4-Pole Speakon®	- Input: XLR+jack connectors - Output: 4-Pole Speakon®	- Input: XLR/Jack combo connectors - Output: 4-pole Speakon® + terminal blocks				
Protections	- Against short-circuits - Signal + current limiter - Against overloads - Thermal protection						
Dimensions (L x W x H)	19" x 1U 483 x 44 x 310 mm	19 inches x 1U: 483 x 44 x 225 mm	19 inches x 1U: 483 x 44 x 225 mm	19 inches x 1U: 483 x 44 x 330 mm	19 inches x 1U: 483 x 44 x 330 mm	19 inches x 1U: 483 x 44 x 330 mm	19 inches x 1U: 483 x 44 x 330 mm
Weight	5.8 kg	3.7 kg	3.7 kg	5.2kg	4.7 kg	4.3 kg	4.5 kg



PE-2400

2 x 1,200Wrms / 4Ω, class H

Code : B00265



PE-900

2 x 450Wrms / 4Ω, class H

Code : B00263



Wi1800

2 x 900W RMS amplifier @ 4Ω 2 x 600W @ 8Ω - Bridgeable @ 4Ω

Code : H9565



Wi1500

2 x 750W RMS amplifier @ 4Ω 2 x 500W @ 8Ω - Bridgeable @ 4Ω

Code : H9564



WA-4X3

4 channel amplifier 4 x 300W RMS @ 4Ω

Code : H9066



	PE-2400	PE-900	Wi1800	Wi1500	WA-4X3
Power	<ul style="list-style-type: none"> - RMS stereo 4Ω: 2 x 1200 W 8 Ω : 2 x 800 W 2 Ω : 2 x 1440 W - Bridged mono 8 Ω : 1 x 2,400W 4Ω: 1 x 2800 W 	<ul style="list-style-type: none"> - RMS stereo 4Ω: 2 x 450 W 8 Ω : 2 x 300 W 2 Ω : 2 x 540 W - Bridged mono 8 Ω : 1 x 900 W 4Ω: 1 x 1080 W 	<ul style="list-style-type: none"> - RMS stereo 4Ω: 2 x 900 W 8 Ω : 2 x 600 W 2 Ω : 2 x 1400 W - Bridged mono 8 Ω : 1 x 1800 W 4Ω: 1 x 2800 W 	<ul style="list-style-type: none"> - RMS stereo 4Ω: 2 x 750W 8 Ω : 2 x 500 W 2 Ω : 2 x 1200 W - Bridged mono 8 Ω : 1 x 1400 W 4Ω: 1 x 2400 W 	<ul style="list-style-type: none"> - RMS stereo 4Ω: 4 x 300 W 8 Ω : 4 x 200 W - Bridged stereo 8 Ω : 2 x 600 W - 2.1 stereo 8 Ω : 2 x 200 W + 1 x 600W bridged
Type of amplification	Class H	Class H	Class H	Class H	Class AB
Damping factor	450	450	350	350	200
Cooling	Front-to-back regulated ventilation				
Connectors	<ul style="list-style-type: none"> - Input: XLR/Jack combo connectors - Output: 4-Pole Speakon® 	<ul style="list-style-type: none"> - Input: XLR/Jack combo connectors - Output: Screw-on terminals + 4-pole Speakon® 		<ul style="list-style-type: none"> - Input: XLR + jack + RCA connectors - Output: Screw-on terminals + 4-pole Speakon® 	
Protections	<ul style="list-style-type: none"> - Against short-circuits and overloads - Automatic current limiter - Against DC current - High-temperature protection 		<ul style="list-style-type: none"> - Against short-circuits - Current limiter - Against voltage deviations - Immunity to radio frequencies - Thermal protection and regulation 		
Dimensions [L x W x H]	19" x 2 U: 483 x 89 x 440 mm		19" x 2 U: 483 x 89 x 420 mm		19" x 2 U: 483 x 89 x 375 mm
Weight	25 kg	16,8 kg	21.2 kg	19.5 kg	16 kg

AMPLIFIERS

			
VX700 II Professional amplifier 2 x 350Wrms / 4Ω. <hr/> Code : B00295	VX400 II Professional amplifier 2 x 200Wrms / 4Ω. <hr/> Code : B00294	VX200 II Professional amplifier 2 x 110Wrms / 4Ω. <hr/> Code : B00293	AS-620 2 x 300W RMS amplifier <hr/> Code : H7593
			

	
AS-420 2 x 200W RMS amplifier <hr/> Code : H7578	AS-220 2 x 120W RMS amplifier <hr/> Code : H7577
	

	VX700 II	VX400 II	VX200 II	AS-620	AS-420	AS-220
Power	- RMS stereo 4Ω: 2 x 350 W 8 Ω : 2 x 200 W - Bridged mono 8 Ω : 1 x 700 W	- RMS stereo 4Ω: 2 x 200 W 8 Ω : 2 x 135 W	- RMS stereo 4Ω: 2 x 110 W 8 Ω : 2 x 65 W - Bridged mono 8 Ω : 1 x 220 W	- RMS stereo 4Ω: 2 x 300 W 8 Ω : 2 x 220 W	- RMS stereo 4Ω: 2 x 200 W 8 Ω : 2 x 100 W	- RMS stereo 4Ω: 2 x 120 W 8 Ω : 2 x 75 W
Type of amplification	Class D	Class D	Class D	Class D	Class D	Class D
Damping factor	200	150	150			
Cooling	Front-to-back regulated ventilation					
Connectors	- Input: XLR + jack connectors - Output: Screw-on terminals + 4-pole Speakon®			- Input: Jack connectors - Output: Speakon®		
Protections	- Against short-circuits - Current limiter - Thermal protection and regulation			- Against short-circuits - Against overloads - Thermal protection		
Dimensions (L x W x H)	19" x 2 U: 483 x 89 x 260 mm		19" x 1U 483 x 44 x 320 mm			19" x 2 U: 483 x 89 x 210 mm
Weight	13 kg	9 kg	9.5 kg	14 kg	10 kg	8 kg



AVM-3

Class D amplifier module for VIBE18-SUB Mk2.

Code : B00242



AVM-2

Class D amplifier module for VIBE15 Mk2, VIBE30 Mk2 and VIBE15-SUB Mk2.

Code : B00241



AVM-1

Class D amplifier module for VIBE8 Mk2, VIBE10 Mk2 & VIBE12 Mk2

Code : B00240



	AVM-3	AVM-2	AVM-1
Power	4Ω: 1200W RMS 8 Ω : 800 W RMS	4Ω: 800 W RMS 8 Ω : 500 W RMS	4Ω: 500 W RMS 8 Ω : 300 W RMS
Type of amplification	Class D		
Damping factor	500		
Cooling	Regulated ventilation		
Connectors	- Input: XLR+jack+RCA connectors - Output: Speakon® 1+/1-		
Protections	- Against short-circuits - Signal + current limiter - Against overloads - Thermal protection		
Dimensions (L x W x H)	320 x 160 x 87 mm	320 x 160 x 87 mm	275 x 145 x 72 mm
Weight	3.4 kg	3.4 kg	2 kg

More information on: www.jb-systems.eu

SOUND PROCESSING



SP26

2IN6OUT sound processor with software

Code : H10712



Inputs: 2 balanced inputs
Outputs: 6 balanced outputs
Sampling rate: 96kHz, 24-bit depth
Crossover / EQ Operational frequency range: 20Hz – 20kHz
Crossover filtering: Bessel, Butterworth (6, 12, 24 and 48dB/octave), Linkwitz-Riley (12 and 24dB/octave)
10-band equaliser: Bell, Notch, All Pass, Band Pass, Low/High Pass, Low/High Shelf
Equaliser gain : adjustable from -12dB to +12dB
Equaliser Q: Adjustable from 0.2 to 25
Phase inversion
Limiter attack time from 10 to 100
Limiter threshold from -48dB to 9dB
Password protection
50 presets available
Dimensions (mm): 483 x 127 x 45 (1U)
Weight: 3kg



Q215

2x15-band equaliser +/- 12dB - 1U

Code : H9670



Stereo equaliser, 2/3 octaves from 31.5Hz to 16kHz
Adjustable output level: +12/-12 dB
20mm faders
Low-cut filter per channel (60Hz -3dB)
Balanced inputs: XLR, 6.35 TRS jack
Unbalanced inputs: RCA
Balanced outputs: XLR, 6.35 TRS jack
Unbalanced outputs: RCA
Recording output (REC OUT) on unbalanced RCA (output level -6 DB)
Signal level indicator: -10DB, 0DB, +10DB, +17DB
Low-cut and bypass indicator
Dimensions: 483 x 44 x 190 mm
Weight: 2.4kg



BEQ-15

2x15-band stereo equaliser.

Code : B00288



2 x 15-band stereo equaliser 2/3 octaves from 25Hz to 16kHz
Adjustable output level: +/-6dB or +/- 12dB
20mm faders
Balanced inputs: XLR, 6.35 TRS jack
Unbalanced inputs: RCA
Balanced outputs: XLR, 6.35 TRS jack
Unbalanced outputs: RCA
Level switch: 6dB/12dB
Equaliser bypass switch
Subsonic filter switch
< 20Hz
Dimensions: 483 x 44 x 165 mm
Weight: 2.5 Kg



X312

2-way stereo or 3-way mono active filter

Code : H9669



Inputs / outputs on balanced XLR + 4dB
Stereo (2-way + subwoofer) or mono (3-way + subwoofer) operation
LOW SUM mode to sum low frequencies from both inputs and output to mono
Lows, mids and highs phase reversal possible
In stereo mode:
- Adjustment of cut-off frequency between highs and lows for each side (45 to 960Hz)
In mono mode:
- Adjustment of cut-off frequency between highs, mids and lows (45 to 960Hz and 450 to 9,600Hz)
- Optional use of SUB output with adjustable level and cut-off frequency (20 to 200Hz)
Dimensions: 483 x 175 x 44mm
Weight: 2kg



XO 2.4

Active filter: 2-way stereo or 3-way mono.

Code : B00287



Balanced XLR inputs and outputs
Stereo or mono operation
Phase reversal switch
40Hz subsonic filter (with on/off switch)
In stereo mode:
- Adjustment of cut-off frequency between highs and lows for each side (45 to 960Hz)
In mono mode:
- Adjustment of cut-off frequency between highs, mids and lows (45 to 960Hz and 450 to 9,600Hz)
Dimensions: 483 x 136 x 44mm
Weight: 2kg



ENH 2.3

Professional multi-band sound enhancer

Code : B00286



Adds harmonics to sound, increasing definition, presence and transparency. Considerably enhances low frequencies (more punch)
Balanced XLR inputs and outputs
Separate subwoofer output with adjustable output level and cut-off frequency from 100 to 250Hz.
Low Mix adjustment for lows HPF from 1 to 8kHz for cut-off frequency
High Mix adjustment for high-mids
Phase reversal switch
CLIP indicator
Level indicator -40/-20/-6/-2dB
Dimensions: 483 x 154 x 44mm
Weight: 1 kg



SDI-1

Stereo DI-box. Converts unbalanced audio signals into balanced signals

Code : B00279



This stereo DI-box is the perfect solution for various applications!
It allows conversion of unbalanced audio signals into balanced signals for transport through long cables.
The "ground lift" switch allows separation of the inputs/outputs to avoid ground loops.
Solid anodised aluminium black housing
1 RCA and XLR/6.35 jack combo input
1 XLR output
Max. input level: +21dBu
Dimensions: 105 x 110 x 44 mm
Weight: 0.440 Kg



BDA-100

Active direct box

Code : H7678



1 unbalanced 6.35 jack input
1 balanced XLR input
1 XLR output
Max. input level: 0/+20/+40dB
Dimensions: 135 x 55 x 130 mm
Weight: 0.700 Kg
9V battery not included



CONVERTER

USB/LINE converter and PHONO with Soft

Code : H9077



Provided with Audacity, the French audio processing software
Comprehensive and efficient tools to optimise the quality of your recording
Simple user interface, allowing to record vinyl records at high speed.
Plug-and-play and driverless operation with most audio software on the market.
2 RCA inputs (L and R), line/phono switch
- 2 RCA outputs (L and R), line level
Cable length: 1.5m



BT10ER2

Bluetooth® 4.2 transmitter-receiver

Code : H10981



Bluetooth® 4.2
Profils Bluetooth® supportés : A2DP et AVRCP
Décodeur Apt-x® CSR™ Low Latency pour une qualité audio HD et une faible latence
Distance de fonctionnement : 10 mètres en moyenne - Class 2
Autonomie jusqu'à 20 heures en moyenne
Batterie : Lithium polymères 270mAh rechargeable
Connectique numérique optique SPDIF et Jack 3,5
Réglage du volume par touches sensibles



BT2xE

Double stereo audio Bluetooth® transmitter

Code : H10413



Bluetooth® 4.1
Bluetooth®profile: A2DP
Audio codecs: aptX-LL, aptX, SBS, FastStream
Operating range: Class 2, 10 meters
Allows for concurrently pairing two devices
Operating battery life:
Up to 8 hours
Battery: Rechargeable, Li-Po, 250mAh
Weight: Housing: 23g / Base: 7g
Dimensions: 48 x 48 x 15 mm



BT-20R

Bluetooth® receiver HD
3.5 jack output + USB charger

Code : H10305



Bluetooth® 4.2
Supported Bluetooth®profiles: apt-X, A2DP and AVRCP
Apt-x® decoder Low Latency 32ms
Operating distance:
10 metres on average - Class 2
Power supply: AC100-240V 50/60Hz
USB output current: 5V / 1A / 5W
3.5mm jack and RCA cable included

SOUND PROCESSING

**DANTE™ is the NEW STANDARD for “Audio over IP” !
Light jockey’s call it “Art-Net for audio” !**

DANTE™ advantages:

- Uncompressed multi-channel audio over standard Ethernet networks.
- No bulky snake cables !
- No more buzzing due to ground loops !
- Cheap CAT5E-cabling + standard Ethernet switches
- Plug & Play : auto discovery, no IP-addresses, no network knowledge required!
- Easy routing of audio signals ! (Free Dante™ Controller software)
- Extremely low latency: ← 1 ms
- Virtual Sound Card: turns any Windows PC / MAC into a Dante™ audio device.
- Up to 512 audio channels per GIGABIT network!
- Automatic discovery of all Dante™ devices on the network
- 1 Universal protocol: no compatibility problems !



NEW



DBI-04
Dante/analog audio bridge, 4out, INSTALL

Code : B08203



EUROBLOCK connector with 4 inputs (only on model DBI-44)
EUROBLOCK connector with 4 outputs
GPI & GPO for extra functionality and control:
4 General Purpose Inputs: can be used to connect an on/off switch, potentiometer (adjustable voltage), ...
4 General Purpose Outputs: can be used to control other equipment (switch equipment or lamps on/off, trigger a Powerpoint presentation, ...)
Power: +24Vdc, PoE (Power over Ethernet)
Port 1+2 activity indication on front
AUDIO DSP with webpage control for extra functionality: compressors, limiters, parametric EQ, ...
8x8 MATRIX: local premix, routing, ...
Optional half 19" mounting bracket: 2 units in 1U 19" rack

NEW



DBI-44
Dante/analog audio bridge, 4in/4out, INSTALL

Code : B08204



EUROBLOCK connector with 4 inputs (only on model DBI-44)
EUROBLOCK connector with 4 outputs
GPI & GPO for extra functionality and control:
4 General Purpose Inputs: can be used to connect an on/off switch, potentiometer (adjustable voltage), ...
Possibility to connect a potentiometer to adjust the volume of one or more inputs and/or outputs
4 General Purpose Outputs: can be used to control other equipment (switch equipment or lamps on/off, trigger a Powerpoint presentation, ...)
Power supply: +24VDC, PoE (Power over Ethernet)
Port 1+2 activity indication on front
AUDIO DSP with webpage control for extra functionality: compressors, limiters, parametric EQ, ...
8x8 MATRIX: local premix, routing, ...
Optional half 19" mounting bracket: 2 units in 1U 19" rack

NEW



DBT-04
Dante/analog audio bridge, 4out, TOURING

Code : B08205



4 Balanced Combo-inputs (only on model DBT-44):
LINE + MIC (-28dB PAD & 48V Phantom)
4 Balanced male XLR-outputs
2 RJ45 Gigabit Ethernet I/O ports with internal switch.
Power: 100-240Vac PowerCON, PoE (Power over Ethernet)
Audio DSP with webpage control for extra functionality:
compressors, limiters, parametric EQ, ...
8x8 MATRIX: local premix, routing, ...
Optional half 19" mounting bracket: 2 units in 1U 19" rack
Rubber corners: for use as stage box

NEW



DBT-44
Dante/analog audio bridge, 4in/4out, TOURING

Code : B08206



4 Balanced Combo-inputs (only on model DBT-44):
LINE + MIC (-24dB PAD & 48V Phantom)
4 Balanced male XLR-outputs
2 RJ45 Gigabit Ethernet I/O ports with internal switch.
Power: 100-240Vac PowerCON, PoE (Power over Ethernet)
Audio DSP with webpage control for extra functionality:
compressors, limiters, parametric EQ, ...
8x8 MATRIX: local premix, routing, ...
Optional half 19" mounting bracket: 2 units in 1U 19" rack
Rubber corners: for use as stage box



DANTE™ requirements:

Currently not all audio equipment can talk Dante™ language. The new Synq Dante™ I/O interfaces translate analog audio to and from Network Audio (Dante™).

Analog → Dante™:

- Connect your MIC to the Dante™ network
- Connect your Guitar, audio player, etc. to the Dante™ network

Dante™ → Analog:

- Connect the Dante™ network to your analog amplifier/active speaker
- Connect the Dante™ network to Recorder with analog input

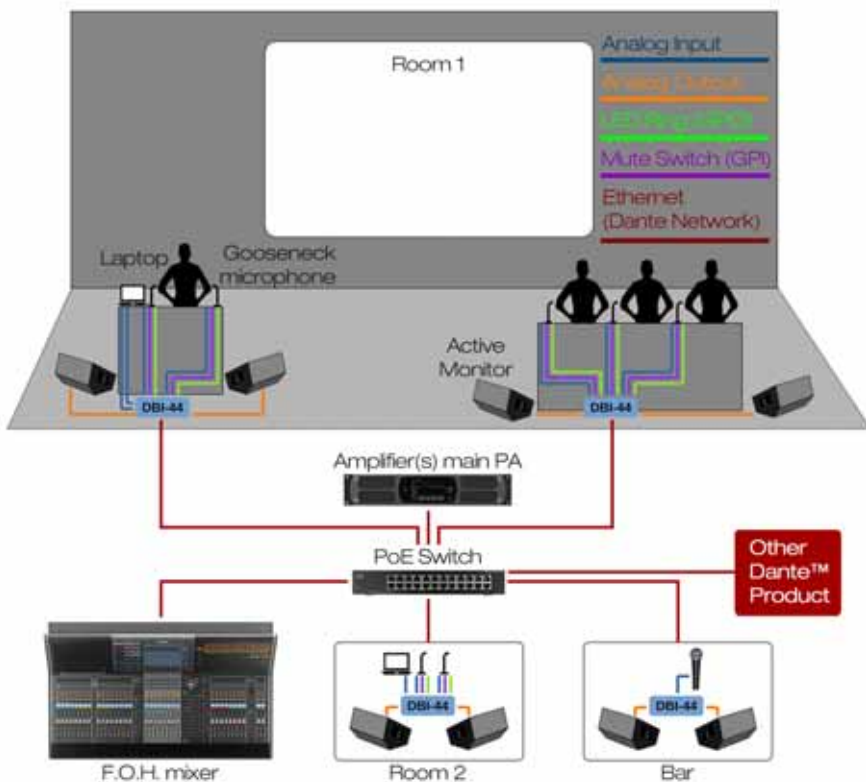

BUILT IN MATRIX AND AUDIO TREATMENT



Multi-room install example using PoE

Room 1:

- Easy cabling :
1 single Cat5e network cable transports all audio signals in both directions. This makes it very easy to expand and modify the existing system.
- A single GPI trigger (here a potentiometer on the desk which is plugged into the DBI-44) sends a signal to the GPO connected devices (the gooseneck microphones and a LED light) to turn them on and off. GPIO can also be used to trigger or communicate with anything else on the network.
- Record and play audio from and to any room on the Dante™ network.

Room 2:

- No need for a separate mixer:
Mix all sources (2 microphones, one audio input from a computer, the audio from the main room) using the DBI-44 its integrated web browser and add EQ, compression, etc.
- If you need extra audio inputs just add an extra DBI-44 box. Thanks to the DBI-44 its integrated 8x8 matrix you can easily mix up to 8 separate inputs.
- GPIO allows you to control the gain of each microphone locally. Just connect a potentiometer to one of the GPI inputs.

Bar:

- The DBI-44 box allows the playback of background music originating from any sound source in the Dante™ network.
- The DBI-44 box also allows to connect an extra microphone for announcements

MIXERS

NEW



Mi3
Mix 3 channels 2 Mic and 1 stereo

Code : H10909



NEW



Mi4U
Mixer 4 channels 2 Mic + 2 stereo and 1 Aux + USB port

Code : H10910



NEW



Mi6U
Mixer 6 channels 4 Mic + 2 stereo and 1 Aux + USB port

Code : H10911



	Mi3	Mi4U	Mi6U
Mic Input	2	2	4
Stereo Input	1	2	2
Aux	-	1	1
Stereo L/R Output	1	2	2
USB port full duplex	-	1	1
Phantom power	+48V DC		
Gain	65dB[MIC main output]		
MIC CH. EQ±15dB	HI: 12kHz, LO:80Hz		
LINE CH. EQ±15dB	HI: 12kHz, LO:80Hz		
Frequency response	(20-20kHz)±1dB		
Maximum Output Level	+20dBu		
Meter	4 segments [-20dB to CLIP]		
Distortion	≲ 0.08%(20-20kHz)		
Power supply	DC 12V external adaptor		
Weight (kg)	0.54	0.78	0.98
Dimension(W*D*H)mm	190x140x68	220x160x68	220x220x68



New series of mixing consoles for live mixing with 16 effects DSP plus compressors on microphone channels.

The integrated USB/SD/BT device avoids the need for additional peripherals for background music.



Bluetooth™



MPX6

Mixer 6 CH + compressor + Effects + USB/SD/BT player

Code : H10905



Bluetooth™



MPX8

Mixer 8 CH + compressor + Effects + USB/SD/BT player

Code : H10906



Bluetooth™



MPX12

12CH Mixer + Compressor + Effects + USB/SD/BT Player

Code : H10907



Bluetooth™



MPX16

16CH Mixer + Compressor + Effects + USB/SD/BT Player

Code : H10908



	MPX6	MPX8	MPX12	MPX16
Inputs	6	8	12	16
Mic Input channels	2	4	8	12
Stereo Input channels	2	2	2	2
Gain	MIN - MAX	MIN - MAX	MIN - MAX	MIN - MAX
Mic	+6dB - +50dB	+6dB - +50dB	+6dB - +50dB	+6dB - +50dB
Line	+10dB - -34dB	+10dB - -34dB	+10dB - -34dB	+10dB - -34dB
EIN	-100dB	-100dB	-100dB	-100dB
Frequency response	-	-	-	-
Mic Channel	10Hz - 20kHz +1/-3	10Hz - 20kHz +1/-3	10Hz - 20kHz +1/-3	10Hz - 20kHz +1/-3
THD Mic Channel	≤0.03%	≤0.03%	≤0.03%	≤0.03%
Signal to noise ratio	80dB	80dB	80dB	80dB
Output Levels	MAX +27(BAL)	MAX +27(BAL)	MAX +27(BAL)	MAX +27(BAL)
	MAX +22(UNBAL)	MAX +22(UNBAL)	MAX +22(UNBAL)	MAX +22(UNBAL)
Hi	2.5kHz	2.5kHz	2.5kHz	2.5kHz
Mid	2.5kHz	2.5kHz	2.5kHz	2.5kHz
Low	45Hz	45Hz	45Hz	45Hz
Low Cut	80Hz	80Hz	80Hz	80Hz
Compressor	YES	YES	YES	YES
+ 48V Phantom power	YES	YES	YES	YES
MP3/USB/SD Media Player	YES	YES	YES	YES
DSP Effects 16 programs	YES	YES	YES	YES
Bluetooth player	YES	YES	YES	YES
Dimensions (W x H x D)	227x70x359(mm)	283x70x359(mm)	395x70x359(mm)	395x70x359(mm)

MIXERS

NEW



LIVEtouch20
LIVEtouch20 - 20 channel digital mixing console

Code : H10901



NEW



LIVEtouch-RACK
Rack for LIVE TOUCH20

Code : H10959



NEW



CASE FOR LIVE TOUCH20
Flight case for LiveTouch20 mixer

Code : B03292



FEATURES

- 12 microphone inputs + 2 stereo inputs
- 1 S/PDIF input/output and 1 AES/EBU output
- 4 mono busses / 5 stereo busses / 1 monitor bus
- 8 assignable XLR outputs
- 1 stereo monitor output and 1 headphone output
- 1 x 7" touch screen
- 8 effect modules
- 2 USB plugs for song recording, song playback and scene backups

TECHNICAL DATA

- Inputs : 12 microphones (4 Combo), 2 stereo, S/PDIF and USB
- Input channel functions : Phase, Delay, high pass filter, 4 band parametric equalizer, noise gate, compressor, pan, effects
- Outputs : 8 assignable XLR, AES/EBU, S/PDIF and headphone
- Internal signal generator : White, sinusoidal and white noise

- Phantom power : 48V independently activatable on each channel
- USB Features : Play and record songs, system update, scene backup and external network card
- Screen : 7-inch, 1024 x 600 pixel, high definition touchscreen
- AD/DA : 192 KHz/24 bits max.
- Sampling frequency : 48 KHz / 44.1 KHz
- DSP : SHARC ADI 40-bit floating point processor, 4th generation, 450M
- Effects : 8 modules: 2 Reverbs, 2 Modulation, 2 Delay and 2 x15 bands graphic equalizers
- Système : Custom Android
- Network : Via 1 external USB module (supplied)
- Remote control : Via 1 iPad application
- Power supply : 100-240V 50/60Hz → DC12V
- Size : 445 x 325 x 100 mm
- Weight : 5.3 Kg

The LiveTouch20 is a 20 channels motorized faders digital mixer with large touch screen and USB ports. Full control is also available remotely via WIFI dongle provided to mix anywhere with your iPad. There are 12 Mic/Line inputs, 2 stereo inputs all routable via 4 mono busses, 4 stereo busses and master L/R.

The 1024x600 touch screen makes navigation simple and intuitive for studio or live applications.





SMP 16.42

16-channel PA mixer with very low background noise architecture

Code : B00152



MX1624

Live Mixer 10 microphones + 2 line + 24-bit DSP 10 FX with USB port

Code : H9560



16-channel mixer with 4 sub-groups and 2 standalone sub-masters .
DSP 24-bit effects processor with 100 presets
Digital audio input/output through USB type B

Inputs:
12 channels with balanced inputs, 8 mono 4 stereo:
Input gain
Mono channel inserts
Peak indicator @ -5dB
High-pass filter @ 75Hz
3-band equaliser with parametric adjustment for mids
1 AUX send pre (monitoring)
1 AUX send with pre/post switch
EFX send for effects selection (post)
PAN / BAL control
Mute button for each channel
PFL inverter
LEVEL with 60mm control fader
G/D selection and sub-groups 1-2-3-4
48-volt phantom power
Outputs:
G/D general control, sub-groups, headphones and control room

Footswitch with 6.35 stereo jack (DSP activation)
2 x 10 sections LED VU-meters
7-band equaliser for master mix
19-inch rack brackets included
Power supply: External
Net weight: 7.3 Kg
Dimensions: 436 x 90 x 420 mm

8 mono / 4 stereo / 10 mic input mixer
24-bit DSP effects processor with 10 presets
Digital audio input/output through USB type B

Input adjustments:
Gain / 3-band equaliser / AUX with Pre/Post switch/ Effects / Balance / Mute / PFL / High-pass filter 75Hz
Output adjustments:
Master level / ALT 3/4 / AUX send, AUX return and EFX return / Headphones and Control Room
Phantom power
Effect selector with level adjustment

Outputs
Master through 2x XLR and 2x 6.35 stereo jacks
ALT 3/4 through 2x 6.35 stereo jacks
AUX outputs, Control Room and headphones through 6.35 stereo jacks
Record output through RCA

Footswitch with 6.35 stereo jack (DSP activation)
19-inch rack brackets included
Power supply: External
Net weight: 5.6 Kg
Dimensions: 436 x 420 x 65 mm

A mix of genres. This range of mixers offers a solution for each use: Ultra-compact mixers for DJs, multiple-input and output consoles, and live consoles with perfectly transparent preamps for optimal playback for optimal sound quality.



MIXERS



MIX 5.2

Mixer with 5 channels and 2 independent zones.

Code : B00119



Inputs

1 microphone with Talkover on front panel
5 microphones on back
4 line
2 phono

Adjustments

3-band equaliser on each output
3-band equaliser on microphone channel 1
Gain adjustment for each channel
Talkover level adjustment
Choice of zone A or B per channel

Outputs

Master A balanced and unbalanced
Master B balanced and unbalanced
Separate records A and B

LED VU-meters with 10 sections
Power supply: AC 230V ~ 50Hz
Dimensions: 483 x 134 x 130 mm
Weight: 2 Kg



MIX6usb

A compact and robust 19" mixer with stylish black design (white and blue LEDs).

Code : B00122



Inputs

1 USB port on channel 1 for playing and recording audio files
2 microphones with Talkover
5 lines,
2 phono or 2 line,
1 USB
Aux on front panel

Adjustments

3-band equaliser on each channel
Gain adjustment for each channel
Talkover level adjustment

Outputs

Balanced Master
Separate Booth and Record
1 USB port

LED VU-meters with 10 sections
Power supply: AC 230V ~ 50Hz
Dimensions: 483 x 179 x 104 mm
Weight: 5.1 Kg



SMI-84

An ideal mixer for any pub, bar, hotel, restaurant, etc.

Code : B00123



Mixing console with 4 zones

- 2 USB ports
- 6 lines through RCA
- 2 phono
- 2 microphones with Talkover
- 1 Aux on front panel

Level adjustment on front panel

Microphone equaliser on front panel
Output equaliser on back

Outputs

Zone A, B, C through XLR mono
Stereo Master through XLR and RCA
All outputs are also Euroblock connectors
Mute key on Euroblock
Priority input on Euroblock
2 USB ports allowing playback and recording via a computer

Power supply: AC 230V ~ 50Hz
Dimensions: 483 x 134 x 184 mm
Weight: 4.2 Kg





BATTLE4-usb

DJ Mixer, 9 inputs on 4 channels [3 line inputs, 2 phono, 2 microphones, 2 USB]

Code : B00126



Inputs
2 USB ports on channels 2 and 3 allowing playback and recording of audio files
3 line inputs
2 phono
2 microphones

Adjustments
3-band equaliser on each channel
2-band equaliser on microphone channel
Gain adjustment for each channel

Outputs
Balanced Master
Separate Booth and Record
2 USB ports

Master LED VU-meters per channel
Power supply: AC 230V – 50Hz
Dimensions: 237 x 315 x 105 mm
Weight: 3.3 Kg



DIGITAL-3

3-channel mixer with 1 microphone and 2 USB

Code : H9254



Inputs
2 USB ports on channels 1 and 3 allowing playback and recording of audio files
3 phono through RCA
3 line through RCA
1 microphone through jack with Talkover

Adjustments
3-band equaliser on each channel
2-band equaliser on microphone channel
Gain adjustment for each channel

Outputs
Master output, high level
2 USB ports

On/off switch
LED VU-meter for Master
External power supply
Dimensions: 254 x 308 x 82.5 mm
Weight: 3.4 kg



DIGITAL-2

2-channel DJ Mixer with 1 microphone and 2 USB

Code : H8682



Inputs
2 USB ports allowing playback and recording of audio files
2 PHONO inputs with switchable RCA connectors
2 LINE inputs with switchable RCA connectors
1 DJ mic input with jack connector and TALKOVER

Adjustments
Low/mid correction -12/+12 dB through DJmic channel
Gain and lows/mids/highs correction -15/+15 on stereo channels

Outputs
Unbalanced Master output through RCA
Headphone output
2 USB ports

General LED VU-meter with 10 sections
External power supply
Dimensions: 178 x 270 x 85 mm
Weight: 1.9 Kg



CLUB7-usb

DJ Mixer, 13 inputs over 7 channels [3 microphones, 5 line, 2 phono or 2 USB, 1 auxiliary]

Code : B00125



Inputs
2 USB ports on channels 2 and 3 allowing playback and recording of audio files
3 microphones with Talkover
5 lines,
2 phono or 2 USB,
1 auxiliary or Player

Integrated USB/SD reader for mp3, WAV or WMA files

Adjustments
3-band equaliser on each channel
Gain adjustment for each channel
Talkover level adjustment

Outputs
Balanced Master
Separate Booth and Record
2 USB ports

LED VU-meters for channels 1-4
Power supply: AC 230V – 50Hz
Dimensions: 483 x 222 x 78 mm
Weight: 4.5 Kg



KM 4.1

Echo unit combined with a small mixer, perfect for karaoke.

Code : B00289



Inputs
2 mic with Talkover on back
2 line

Adjustments
General 3-band equaliser
Level adjustment for each input
General level adjustment
Echo chamber adjustment (delay, repeat, echo)

Output
Unbalanced mix output

Power supply: AC 230V – 50Hz
Dimensions: 483 x 44 x 180 mm
Weight: 2 Kg

MIDI CONTROLLERS



DJ-KONTROL 4

Professional 4-channel MIDI controller for DJ

Code : B00385



Windows
macOS

Controller
MIDI-compatible DJ software controller (MacOS and Windows)
Thanks to the MIDI communication protocol, this controller can be used with any other MIDI DJ software.
8 large touch-sensitive buttons for cues, loops, samples and effect adjustment.
Scratching jog wheel with coloured backlight.
Latest version of VirtualDJ LE included

Mixer:
3-band equaliser with additional filter adjustment button.
Microphone input.
Headphone output with PFL/MIX
XLR and RCA master outputs
RCA monitor output
RCA record output
2 stereo RCA line inputs

A/D Conversion: 24-bit

LED VU-meter
Power supply: USB 5V 500mA or 5V 1A external power supply
Dimensions: 533 x 280 x 70 mm
Weight: 2 kg

Can be used on up-to-date computer with Windows® XP/Vista/7/8/10 or Mac® OSX



DJ-KONTROL 3S

Professional MIDI controller for DJs (travelling DJ, clubs, studios, etc.).

Code : B00384



Windows
macOS

Controller
MIDI-compatible DJ software controller (MacOS and Windows)
Thanks to the MIDI communication protocol, this controller can be used with any MIDI software for DJs.
Most buttons are backlit: easy to use in the dark.
Touch-sensitive scratching jog wheels with blue backlight

Provided with the latest version of VirtualDJ LE
Mixer:
3-band equaliser with push-kill button
DJ mic input
PFL headphone output
Crossfader curve adjustment. XLR and RCA master outputs

Integrated 24-bit/192kHz sound card

LED VU-meter
Power supply: USB 5V 500mA
Dimensions: 320 x 240 x 65 mm
Weight: 1.4 kg

Can be used on up-to-date computer with Windows® XP/Vista/7/8/10 or Mac® OSX



Brackets for DJ-KONTROL 3
19" brackets for DJ-KONTROL 3 and 3S.

Code : B00392



19" brackets for DJ-KONTROL 3 and 3S.

ADD DJAZZ TO YOUR MIX

DJazz Pro is a complete DJ controller allowing you to mix music on your Mac or PC by playing loops, samples, effects, etc. Versatile, easy to use and with unlimited possibilities, DJazz offers the best in DJ controllers, whether you are a beginner or professional.

Compatible with all the major software, its universal consumer or professional connectivity, its complete and fully-integrated software deliver a tool software make it a tool really focused on the pleasure of playing music.



DJazz Pro

Professional DJ MIDI control surface with multi-channel ASIO sound card

Code : H9923



Windows
macOS

DJ software controller compatible with MIDI (Mac OS X and Windows)
- Native MIDI compatibility (driverless)
- Standard MIDI USB input/output

Complete digital audio interface
- Compatible with Windows (WDM) without driver
- Compatible with Windows via ASIO driver (multitrack)
- Compatible with MacOSX (Core Audio) without driver
- Dedicated ASIO driver included
- 1 line/phono stereo input through RCA compatible with CD/Vinyl Timecode
- 1 line/phono stereo input through RCA with input gain management and Thru mode, compatible with CD/Vinyl Timecode
- 1 aux stereo input through mini-jack with input gain management and Thru mode

- 1 mic input through 6.35 jack
- Headphone with Cue/Mix
- Balanced output through 6.35 jack
- Unbalanced output through RCA
- REC output through USB port

- A/D Conversion: 24-bit – 96kHz
- Sampling rate: 16-bit 44.1/48kHz

Other specifications
- Power supply: USB 5V 500mA
- Optional external power supply: 6V 2.0A
- Dimensions: 410 x 297 x 65 mm
- Weight: 2.9 kg

Provided with Virtual DJ LE, ASIO driver, and mapping for Virtual DJ Pro and Traktor Pro
Can be used on up-to-date computer with Windows® XP/Vista/7/8/10 or Mac® OSX

CD PLAYERS



Adjustable automatic and manual loops, effects synchronised to tempo, HotCue, Samples and and Scratch are just some examples of its capacity.

Capable of reading mp3 CDs, and USB supports (keys or hard drives), it transforms into a controller that can be used with most DJ software, and allows you to play using all supports.



CDX6
CD/USB mass storage player and MIDI controller

Code : H9574



Windows
macOS

CD MP3 slot in reader
USB reader on two ports for keys or external hard drive.
MIDI controller via USB on back

DSP with Echo, Flanger, Filter, Reverse and Scratch effects.
Touch sensitive panel with illuminated ring for control
3 Jog modes: Vinyl, BEND and A.Cue scratch

Adjustable pitch with Master Tempo
4 HOT CUE points
4 samples in memory
Synchronisation of effects with tempo
Adjustable smart loop
Auto or manual BPM



Next track reserve to choose next track to be played
USB link to connect two players to a shared hard drive

Large screen with VFD display
ID3Tag visualisation of artists, titles and genres
Tree structure mp3 file search system.

Xstart for cue start with crossfader on equipped mixers

Dimensions: 296 x 218 x 104 mm
Weight: 2.4kg

Can be used on up-to-date computer with Windows® XP/Vista/7/8/10 or Mac® OSX



CDX4
USB and CD mp3 player with effects and SMART LOOP

Code : H9812



CD MP3 slot in reader
USB mass storage player for USB drive or hard drive

DSP with Scratch, Flanger, Filter, Echo, Reverse effects with adjustable level and settings.
Multifunction touch-sensitive rotary table

Adjustable pitch with Master Tone
SMART LOOP: Loop with adjustable length according to tempo
Auto loop with adjustable length according to tempo
AVM: Anti Vibration Memory
Auto-Cue and track order programming

Highly readable blue LCD display
ID3Tag visualisation of artists, titles and genres
Tree structure mp3 file search system.

Analogue and digital output
Xstart and Relay connections

Dimensions: 220 x 315 x 100 mm
Weight: 2.5 kg





CD/USB/SD players. Rack-mountable CD, USB or SD players for live applications in sound booth, with DJ, theatre, or entertainment-oriented functions, you will certainly find a model that suits your needs among our players.

USB 1.1 REC
CD/USB player + recorder

Code : B00365



CD Mp3, Wave and CDA player
USB player with double USB mass-storage input (on front and back)

Lossless recording from an external source in WAV or MP3 files (bitrate: 64, 128, 192, 256 and 320kbit/s), even during playback of CD tracks or USB devices. Auto or manual recording processor: for a simple recording process without distortion

Variable pitch with Master Tone
Auto and manual BPM, perfect loop (IN/OUT/RELOOP)
AVM: Anti Vibration Memory
Auto CUE

Large screen with VFD display
ID3Tag visualisation of artists, titles and genres
Tree structure mp3 file search system.

Infrared remote control included for playback, recording, looping, search, pitch, and volume functions.

Right/left output through XLR and RCA

Dimensions: 482 x 89 x 270 mm
Weight: 4.35 kg



MPu320
Double CD player with two USB mass-storage ports and touch-sensitive jog wheels

Code : H9681



Double CD player, Mp3, Wave and CDA
USB player with double USB mass-storage input (on front and back)

Jog wheel with two modes: Jog scratch and pitch bend
Variable pitch with Master Tone
Auto and manual BPM, perfect loop (IN/OUT/RELOOP)
AVM: Anti Vibration Memory
Auto CUE

Large screen with VFD display
ID3Tag visualisation of artists, titles and genres
Tree structure mp3 file search system.

Xstart for cue start with crossfader on equipped mixers, Relay for continuous playback

Player dimensions 482 x 89 x 263 mm
Remote dimensions 482 x 91 x 94 mm
Weight: 5.1kg (player) 1.9kg (remote)



MPu310
Mp3-compatible CD/USB player with infrared remote and XLR/RCA output

Code : H9680



CD Mp3, Wave and CDA player
USB player with double USB mass-storage input (on front and back)

Variable pitch with Master Tone
Auto and manual BPM, perfect loop (IN/OUT/RELOOP)
AVM: Anti Vibration Memory
Auto CUE

Large screen with VFD display
ID3Tag visualisation of artists, titles and genres
Tree structure mp3 file search system.

Infrared remote control included for playback, recording, looping, search, pitch, and volume functions.

Right/left output through XLR and RCA

Dimensions: 482 x 89 x 270 mm
Weight: 5.1 kg

VINYL TURNTABLES

Back to the source. Listen to your favourite albums on high-quality vinyl, protect your collection with easy-to-use solutions offering unmatched sound quality thanks to our vinyl-dedicated range of products.



XTRM-1

Direct Super High torque motor + line out

Code : B00322



Direct Drive 3-phase Super High Torque motor with extreme torque of 4.5kg/cm
Adjustable start and stop time from 0.2 to 6 seconds
3 speeds: 33, 45, 78 rpm with quartz lock and optical sensors
Pitch at $\pm 10\%$ $\pm 20\%$ $\pm 50\%$
Standard or reverse playback
2 Start/Stop buttons
White LED lighting on cartridge
Phono or Line output on back
High-quality S-shaped metal tonearm with adjustable height.
Special anti-resonant frame
Tall adjustable support legs
Dimensions: 450 x 353 x 86 mm
Weight: 12 kg
Comes with cartridge holder, felt mat and 45 rpm adapter



Q1usb

Belt drive
USB + line output

Code : B00352



Belt-drive motor Quick start/stop
2 speeds: 33, 45 rpm
Pitch at $\pm 10\%$
Phono or Line output on back
Retractable white lighting on cartridge
S-shaped metal tonearm assembled with:
- Counterweight- Anti-skating control - Arm lever
Adjustable support legs to level the turntable
Dimensions: 450 x 350 x 150 mm
Weight: 9.0 kg

USB output for direct recording onto any computer using Audacity software, which can be downloaded for free, so as to:
change the speed and key, reduce noise, equalise, import and export files, etc.

Comes with dust cover, Audio Technica cartridge, USB cable, felt mat, 45 rpm adapter



TT-CASE

High-quality modern flight-case for DJ turntables (T2, T3, X-TRM1, SL1200, etc.).

Code : B03206

ATN3600L

Audio Technica AT3600 & AT3600L replacement needle
Code: B08200

22€^{Incl. VAT}

AT91/BL

Hi-Fi Audio Technica AT91BL cartridge
Code: B08201

35€^{Incl. VAT}

ATN91

Audio-Technica ATN91 replacement needle
Code: B08202

22€^{Incl. VAT}



RW2

Micro headband, condensing cell, light color

Code : H10946



Type: Condenser Omni-directional
Connection: Mini XLR
Imp.dance : 2.2K Ohms @ 1kHz
Frequency response: 70Hz - 16kHz
Sensitivity: -42dB +/-3dB
Weight: 21 g

High-quality modern flight-case for DJ turntables (T2, T3, X-TRM1, SL1200, ...).
2 butterfly latches, solid handle, interior finish in shock-absorbing foam rubber

MICROPHONES



Hear the difference with the range of microphones and HF systems from Audiophony® and JBsystems®. These models are amongst the greatest references of the audio world, constantly striving for better performance and ergonomics in the service of sound professionals.



RP1
Dynamic cardioid microphone for voice

Code : H9654



Use: Vocals
Type: Dynamic cardioid
Finish: Moulded aluminium body, reinforced anti-shock grill and pop filter
Connection: XLR
Impedance: 600Ω +/-30% @ 1KHz
Frequency response: 70Hz - 16kHz
Sensitivity: -53dB +/-3dB
Weight: 360 g
Dimensions: 180 x 53mm



RS1
Dynamic microphone for voice

Code : H9653



Use: Vocals
Type: Dynamic cardioid
Finish: Moulded aluminium body, reinforced anti-shock grill and pop filter
Connection: XLR
Impedance: 600Ω +/-30% @ 1KHz
Frequency response: 40Hz - 16kHz
Sensitivity: -52dB +/-3dB
Weight: 355 g
Dimensions: 185 x 50 mm



JB27
Professional microphone

Code : B00410



Use: Vocals
Type: Dynamic cardioid
Finish: Moulded aluminium body, reinforced anti-shock grill and pop filter with ON/OFF
Connection: XLR
Impedance: 250Ω
Frequency response: 50Hz - 18kHz
Sensitivity: -72dB
Comes with case, clamp and 6m XLR to mono jack cable



JB10
Professional dynamic microphone

Code : B00402



Use: Dynamic microphone for entertainment and speech
Type: Dynamic cardioid
Finish: Metal body and solid build with ON/OFF button
Connection: XLR
Impedance: 500 Ω
Frequency response: 70Hz - 14kHz
Sensitivity: -75dB
Comes with case, clamp and 6m XLR to mono jack cable



DMC62
Dynamic microphone for entertainment and speech

Code : H9652



Use: Dynamic microphone for entertainment and speech
Type: Dynamic cardioid
Finish: Metal body and solid build with ON/OFF button
Connection: XLR
Impedance: 500 Ω
Frequency response: 80Hz - 15kHz
Sensitivity: -54dB
Comes with case, clamp and 6m XLR to mono jack cable



JB5
Semi-professional dynamic microphone for DJ, voice or music

Code : B00408



Use: Dynamic microphone for entertainment and speech
Type: Dynamic cardioid
Finish: Metal body and solid build with ON/OFF button
Connection: moulded cable with jack connector
Impedance: 600 Ω
Frequency response: 100Hz - 12kHz
Sensitivity: -74dB
Comes with 2m mono jack cable



JB30
Gooseneck microphone

Code : B00411



Use: Dynamic gooseneck microphone for speech
Type: Unidirectional microphone
Finish: 30cm metal gooseneck with ON/OFF button
Connection: XLR
Impedance: 500 Ω
Frequency response: 80Hz - 14kHz
Sensitivity: -74dB



JB33
Suitable for conferences, etc.

Code : B00406



Use: Conference gooseneck microphone
Type: Condenser Electret 1.5V
Finish: 23cm metal gooseneck with ON/Standby/OFF button
Connection: 3.5 and 6.35 jack
Impedance: 1000 Ω
Frequency response: 70Hz - 16kHz
Sensitivity: -66dB

MICROPHONES



PACK-UHF410-Head

Code : H10283



Pack including:
 1 UHF410-Base receiver
 1 UHF410-Body waistband transmitter
 1 UHF410-Head headset microphone
 1 carrying case



PACK-UHF410-Lava

Code : H10284



Pack including:
 1 UHF410-Base receiver
 1 UHF410-Body waistband transmitter
 1 UHF410-Lava lavalier microphone
 1 carrying case



PACK-UHF410-Hand

Code : H10282



Pack including:
 1 UHF410-Base receiver
 1 UHF410-Hand handheld microphone
 1 carrying case



UHF410-Base

UHF true diversity receiver with auto scan and sync function

Code : H10271



True Diversity receiver
 Frequency ranges UHF 823 ~ 832 and 863 ~ 865 MHz, 4G compatible
 Programmed frequencies with auto-scan function
 Presets for 4 groups, 4 channels
 LCD display: frequency, group, channel, RF & AF
 Balanced and unbalanced audio output through XLR and 6.35 mono jack
 Line or Mic level
 Volume level adjusted through rotary switch on front
 Detachable BNC antennae, multiple accessories available
 Power supply: 12V DC (adapter provided)
 Dimensions: 200 x 42 x 183mm (rack-mountable 19 inch by two)



UHF410-Hand

Condenser handheld microphone transmitter

Code : H10272



Handheld electret condenser microphone
 True Diversity transmitter
New frequency ranges UHF 823 ~ 832 and 863 ~ 865 MHz, 4G compatible
 Output power: 10mW (max.)
 40 programmed frequencies with SYNC function
 LCD display: channel, battery level
 Power supply: 2 AA 1.5V batteries (not included)
 Average battery life: 10 hours
 Dimensions: 260 x 54mm diameter



UHF410-Body

UHF diversity waistband transmitters

Code : H10273



True Diversity Transmitter
New frequency ranges UHF 823 ~ 832 and 863 ~ 865 MHz, 4G compatible
 Output power: 10mW (max.)
 40 channels with auto-scan function
 LCD display: channel, battery level
 Mic input through mini XLR
 Gain level -10/0/+10dB
 Power supply: 2x AA type 1.5V batteries (not included)
 Battery life: 10 hours on average
 Dimensions: 98 x 65 x 25mm (+ 75mm for antenna)



UHF410-Head

Sweatproof headset microphone

Code : H10274



Sweatproof headset electret condenser microphone, ideal for sport clubs
 Sensitivity: -47 ±4dB
 Polarity: Unidirectional cardioid
 Frequency response: 100Hz - 10KHz
 Operating voltage: 1.5V
 Power consumption: 0.5mA max.
 Signal to noise ratio: Higher than 60dB
 Accessories included: Windscreen
 Connectivity: Mini XLR



UHF410-Lava

Discrete lavalier condenser microphone

Code : H10275



Miniature lavalier electret condenser microphone
 Sensitivity: -47 ±4dB
 Polarity: Omnidirectional cardioid
 Frequency response: 50Hz - 10KHz
 Operating voltage: 1.5V
 Power consumption: 0.5mA max.
 Signal to noise ratio: Higher than 58dB
 Accessories included: Windscreen and fastening pin
 Connectivity: Mini XLR
 Dimensions: 37 x 5.5mm diameter



UHF-410-Boost

Booster antenna with BNC connector

Code : H10276



Gain from 9 dB +/-1dB
Frequency range: 550-950MHz
Operating voltage: 8V
Impedance 50Ω



UHF410-Hold

Antenna support with BNC connector

Code : H10277



5/8" threading for microphone stand and male/male BNC connector



UHF410-Split

2-in-1 Splitter IN/OUT with BNC connector

Code : H10278



Frequency range: 400 ~ 1000MHz
Stationary wave report (VSWR): < 2
Input impedance: 50 Ω
Isolation: 18dB
Loss: < 3dB
Connectors: BNC
Dimensions: 77 x 64 x 26 mm



UHF410-Ant

Long range directional antenna with BNC connector

Code : H10279



Frequency range: 500 ~ 950 MHz
Beam width:
80° E-plane, 140° H-plane
Impedance: 50 Ω
Connector: BNC
Dimensions: 295 x 210 x 31 mm



UHF410-Rall1m

BNC/BNC 1 metre antenna extension cable

Code : H10280



UHF410-Rall10m

BNC/BNC 10 metre antenna extension cable

Code : H10281



UHF410-BNC2

BNC/BNC connector for bracket

Code : H10639



UHF410-Rack

Long bracket for receiver

Code : H10640



UHF410-BNC1

BNC/BNC connector for extension

Code : H10641



The UHF410 range benefits from the latest technological developments for an optimal transmission quality.

This range meets European requirements and uses the frequency ranges 823 ~ 832 and 863 ~ 865 MHz, that are compatible with 4G.



MICROPHONES



GO-Lava pack

Code : H10000



GO-Head pack

Code : H10001



GO-Hand pack

Code : H9999



GO-Mono

UHF diversity receiver, 16 frequencies for 1 transmitter

Code : H9988



Pack including:
1 GO-MONO receiver
1 GO-MONO waist transmitter
1 GO-Lava lavalier mic

Pack including:
1 GO-MONO receiver
1 GO-Body waist transmitter
1 GO-Head headset microphone

Pack including:
1 GO-MONO receiver
1 GO-Hand handheld microphone

UHF 16-frequency receiver
Frequency ranges UHF 823 – 832 and 863 – 865 MHz, 4G compatible
Diversity system for reception free of micro-cuts.
Adjustable squelch for parasite absorption
Simultaneous operation of 4 receivers (4 mics)
Adjustable antennae on front
Average range 70m in ideal conditions
Balanced XLR and unbalanced jack outputs
Rack-mountable by two via FREE-RACK (optional)
Dimensions: 130 x 36 x 92 mm

The UHF GO range benefits from the latest technological developments for an optimal transmission quality.

Equipped with entirely redesigned electronics, the transmitters and receivers now allow using 4 microphones simultaneously with an optimal reception quality.

Easy to use, the GO Mono transmitter allows receiving from a Diversity transmitter, with a choice of 16 frequencies.

- **Compatible with the new TNT and 4G frequencies**
- **Up to 4 mics simultaneously**
- **Balanced and unbalanced output**
- **Implies the use of 4 transmitters and 4 receivers in the GO range**





GOHand

UHF transmitter handheld condenser microphone

Code : H9989



Handheld microphone only
Must be paired with a GO-MONO receiver
Frequency ranges UHF 823 ~ 832 and 863 ~ 865 MHz, 4G compatible
High-end Electret condenser capsule
Distortion rate lower than 1% @ 1kHz
Works with AA-type 1.5V batteries
Dimensions: 237 x 58 mm



GOBody

Waist transmitter housing for lavalier or headset microphone

Code : H9990



Pocket UHF transmitter 16 frequencies
Frequency ranges UHF 823 ~ 832 and 863 ~ 865 MHz, 4G compatible
Mini XLR connector
Adjustable impedance on either Line or Mic position
Works with AA-type 1.5V batteries
Dimensions: 65 x 100 x 27 mm



GOHead

Mini XLR condenser headset microphone

Code : H9991



Headset microphone only
Must be paired with a GO-BODY transmitter and a GO-MONO receiver.
Mini XLR connector
Comes with windscreen and adjustable headband
Unidirectional condenser capsule
Frequency response: 100Hz to 16kHz
S/N: > 60dB
Impedance: 2.2 kOhms

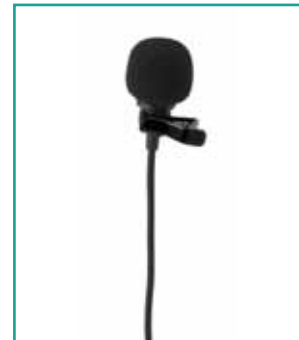

GOLava

Mini XLR condenser lavalier microphone

Code : H9992



Lavalier microphone only
Must be paired with a GO-BODY transmitter and a GO-MONO receiver.
Mini XLR connector
Comes with windscreen and clamp
Unidirectional condenser capsule
Frequency response: 100Hz to 16kHz
S/N: > 60dB
Impedance: 2.2 kOhms

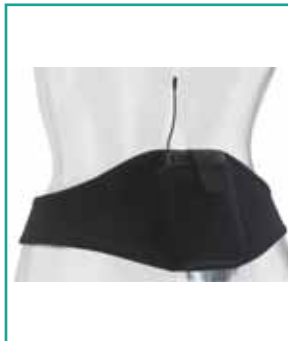

BODYPOCKET

Neoprene waistband for UHF-BODY transmitter

Code : H10484



Compatible with most transmitters on the market
Ideal for sports clubs



MICRO CASE 3U

Rack 19" 3U 230mm/300mm

Code : B03221



Flight case for 19-inch HF microphone receiver.
Depth 230mm (300mm with cover)



FREE-RACK

19 inch rack bracket for 2 GO receivers

Code : H9374



Material: Steel
Finish: Black paint

MICROPHONES



WMS-10

UHF wireless microphone system comprising WMIC-10 handheld microphone and receiver.

Code : B00438



WBS-20

UHF wireless microphone system comprising WBP-20 waistband housing, lavalier microphone and receiver.

Code : B00439



WBP-20

Optional waistband housing.

Code : B00441



UHF wireless microphone system comprising WMIC-10 handheld microphone and 16-frequency UHF receiver.
 Frequency range: 863 – 865 MHz
 Diversity system for reception free of micro-cuts.
 Adjustable squelch for parasite absorption
 Simultaneous operation of 4 receivers (4 mics)
 Adjustable antennae on front
 Balanced XLR and unbalanced jack outputs
 Rack-mountable by two via RP-WMIC 19" (optional)
 UHF handheld microphone with 16 frequencies
 Dynamic unidirectional capsule
 Distortion rate lower than 1% @ 1kHz
 Works with AA-type 1.5V batteries

UHF wireless microphone system comprising WBP-20 waistband housing, lavalier microphone and 16-frequency UHF receiver.
 Frequency range: 863 – 865 MHz
 Diversity system for reception free of micro-cuts.
 Adjustable squelch for parasite absorption
 Simultaneous operation of 4 receivers (4 mics)
 Adjustable antennae on front
 Balanced XLR and unbalanced jack outputs
 Rack-mountable by two via RP-WMIC 19" (optional)
 UHF waistband housing with 16 frequencies
 Mini XLR connector
 Adjustable impedance on either Line or Mic position
 Works with AA-type 1.5V batteries
 Distortion rate lower than 1% @ 1kHz

UHF waistband housing with 16 frequencies
 Mini XLR connector
 Adjustable impedance on either Line or Mic position
 Works with AA-type 1.5V batteries
 Distortion rate lower than 1% @ 1kHz

Unidirectional Electret capsule lavalier microphone



WMIC-10

UHF receiver handheld microphone

Code : B00440



WHS-20

Mini XLR condenser headset microphone

Code : B00442



RP-WMIC

19" adapter for 1 or 2 receivers (WMS-1 or WBS-2 set).

Code : B00437



UHF handheld microphone with 16 frequencies
 Dynamic unidirectional capsule
 Distortion rate lower than 1% @ 1kHz
 Works with AA-type 1.5V batteries

Headset microphone for musicians, teachers and fitness clubs
 Must be paired with a WBP-20 transmitter
 Mini XLR connector
 Comes with windscreen and adjustable headband
 Unidirectional condenser capsule
 Frequency response: 100Hz to 16kHz
 S/N: > 60dB
 Impedance: 2.2 kOhms

19" adapter for 1 or 2 receivers (WMS-1 or WBS-2 set).



The Wave was designed to provide high-fidelity vocal reproduction. Ideal for events and presentations, you can count on its battery life and long range for a VHF microphone. Its dynamic capsule perfectly preserves the timbre and intonation of your voice.

VHF receiver with handheld microphone. 2 available frequencies: VHF 177.5MHz and 185.3MHz for simultaneous use of two microphones.

- **Compatible with TNT and 4G frequencies**
- **Battery life of almost 8 hours**
- **Dynamic handheld microphone**
- **Range up to 50m**



WAVE-F1

VHF receiver with handheld microphone.

Code : H9549



WAVE-F2

VHF receiver with handheld microphone.

Code : H9550



Carrier frequency:
- 177.5MHz for WAVE-F1

- Receiver:
- Output level adjustment to avoid signal saturation.
 - Unbalanced 6.35 jack output (jack/ jack cord provided)
 - AC adapter power supply included: DC 9V 300mA

- Transmitter microphone:
- Dynamic cardioid capsule handheld microphone.
 - Plastic body and reinforced metal grill.
 - OFF/Mute/ON switch
 - Pop filter.
 - Frequency response: 40 to 13kHz
 - Signal to noise ratio: 80 dB
 - Range: up to 50m on average with no dead zone
 - 9V (6LR-61) battery powered (included)

Carrier frequency:
- 185.3MHz

Other features identical to WAVE-F1

AUDIO HEADPHONES

NEW



HEADZ ONE
The ultimate multimedia headhone

Code : B08300



Specifications Headphones:
Frequency Response: 10 – 20.000Hz
SPL: 97dB ± 3dB at 1mW
Impedance: 32Ω
Weight: 200g (without cable)
Specifications Microphone:
Type: Omnidirectional Condenser
Microphone
Frequency Response: 50Hz – 18KHz
Sensitivity: -62dB ± 3dB at 1 KHz
Impedance: 8.2KΩ
Link output



HPS-2
Professional DJ headphones

Code : B00508



Transducer type: Dynamic
Driver diameter: 50mm
Impedance: 29 Ω
Sensitivity: 101 dB +/-3 dB
Power handling: 1000mW
Frequency response: 15 Hz - 22 kHz
Cable: 3m coiled cable and smartphone cable with integrated microphone
Connectivity: 3.5mm with 6.35mm adapter included
Weight: 280 g



DJ-950
Closed dynamic headphones with directional earpieces and bass boost. Special for DJ.

Code : H8222



Driver diameter: 57 mm
Impedance: 64 Ω
Sensitivity: 113 dB
Maximum power: 3.5W
Frequency response: 5 - 30kHz
Cable: 4m with 3.5/6.35 jack adapter and right-angled 6.35
Carrying case and replacement ear pads included



HP2000 PRO
Professional high-performance earphones for DJ.

Code : B00505



Driver diameter: 57 mm
Impedance: 64 Ω
Sensitivity: 107 dB
Maximum power: 3500 mW
Frequency response: 5 - 30kHz
Cable: 3m coiled cable with 3.5/6.35 jack adapter and right-angled 6.35
Carrying case and replacement ear pads included
Weight: 290 g



DJ-930
Dynamic semi-closed headphones with directional earpieces

Code : H8223



Driver diameter: 57 mm
Impedance: 64 Ω
Sensitivity: 107 dB
Maximum power: 3.5W
Frequency response: 30 - 18 kHz
Cable: 4m with 3.5/6.35 jack adapter
Carrying case included





HeadZ Fuchsia

The best of light earphones + mic with outstanding sound quality for your smartphone, tablet, laptop, etc.

Code : B00512



HeadZ White

The best of light earphones + mic with outstanding sound quality for your smartphone, tablet, laptop, etc.

Code : B00513



YBT-100G

High-fidelity Bluetooth stereo headphones
Comes with carrying case

Code : H10303

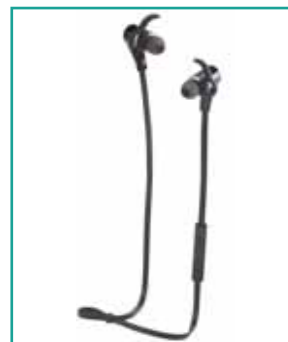

YBT-100S

High-fidelity Bluetooth stereo headphones
Comes with carrying case

Code : H10304



Headphones for smartphone, tablet or laptop
Driver diameter: 38 mm
Impedance: 64 Ω
Sensitivity: 98 dB
Frequency response: 10 - 20 kHz
Cable: with integrated microphone and computer adapter
Weight: 160 g
Link output
Fuschia pink colour

Headphones for smartphone, tablet or laptop
Driver diameter: 38 mm
Impedance: 64 Ω
Sensitivity: 98 dB
Frequency response: 10 - 20 kHz
Cable: with integrated microphone and computer adapter
Weight: 160 g
Link output
White colour

Compatible with all Bluetooth® devices
Bluetooth® 4.0 Class 2
Supported Bluetooth protocols: V4.0 CSR HFP, A2DP, AVRCP, vocal aids
Communication distance: Up to 10 meters -
Average battery life: 8 hours music playback
IPX5 (sweat and rain resistant)
Battery: Lithium 85mAh
Output level: 100dB max.
Frequency response: 20Hz-20KHz
Signal to noise ratio: >70dB
Distortion: <0.1%
Weight: 14 g

Comes with protection box, charging cable, ear-fit silicon tips

ALWAYS BY YOUR SIDE

Our range of headphones covers all areas: Street, Studio, DJing or Audiophile. Whether you choose Bluetooth® or other headphones, sound excellence, fit and design remain the main focus of our creations. Our models are amongst the greatest references of the audio world, serving individuals and professionals alike.





PORTABLE SOUND SYSTEMS

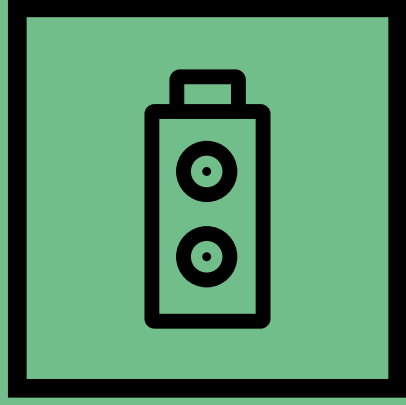

PORTABLE SOUND SYSTEMS

Ultra mobility à la carte. Get out and about, and take your sound system with you wherever you go. From ultra-portable to ultra-powerful, from basic units to comprehensive sound systems, our extensive range covers all uses.



CR25A-COMBO

Battery-powered portable sound system, 250 W RMS with BT, USB reader and two UHF microphones

Code : H10789



CR12A-COMBO

Battery-powered portable sound system, 120 W RMS with BT, USB reader and two UHF microphones

Code : H10209



Power rating: 250 W [2 channels]
Loudspeaker: 12" loudspeaker + 1.35" driver
Microphones supplied : Two hand-held UHF microphones, 16 selectable frequencies
4G-compatible frequency ranges: UHF 823 to 832 MHz and 863 to 865 MHz
Free UHF microphone slot: No
Source: USB/SD reader + Bluetooth®
Free music player slot: No
Inputs: Two LINE inputs on 3.5 mm stereo jack or RCA, two MIC/LINE inputs on combined XLR/Jack
Echo chamber with adjustable delay
Outputs: One LINE level on 6.35 mm TRS jack
Battery: 2 x 18 V / 7 Ah NP
Battery life: 5 hours (average)
Weight: 24,5 kg
Dimensions: 615 x 350 x 395mm
Accessories supplied: Built-in trolley, infrared remote control

Options:
COV-CR25A (protective cover)
CR12A-HEADSET (pocket UHF transmitter and headset microphone)

Power rating: 120 W [2 channels]
Loudspeaker: 10" loudspeaker + 1" driver
Microphones supplied : Two hand-held UHF microphones, 16 selectable frequencies
4G-compatible frequency ranges: UHF 823 to 832 MHz and 863 to 865 MHz
Free UHF microphone slot: No
Source: USB/SD reader + Bluetooth®
Free music player slot: No
Inputs: Two LINE inputs on 3.5 mm stereo jack or RCA, two MIC/LINE inputs on combined XLR/Jack
Outputs: One LINE level on 6.35 mm TRS jack
Battery: 2 x 12 V / 5 Ah NP
Battery life: 6 hours (average)
Weight: 17,3 kg
Dimensions: 550 x 340 x 300 mm
Accessories supplied: Built-in trolley, infrared remote control

Options:
COV-CR12A (protective cover)
CR12A-HEADSET (pocket UHF transmitter and headset microphone)



COV-CR25A

Protective cover for CR25A-COMBO

Code : H10791



COV-CR12A

Case for CR12A-COMBO loudspeaker

Code : H10208



Rear view of CR12A-COMBO loudspeaker



SPRINTER-One-V122

Battery-powered portable sound system, 120 W, without built-in sources

Code : H9977



SPRINTER122

Battery-powered portable sound system, 120 W with BT, MP3 CD/USB/SD reader and one UHF microphone

Code : H9837



CROSSER180

Battery-powered portable sound system, 180 W with BT, MP3 CD/USB/SD reader and one UHF microphone

Code : H9895



CROSSER-One-V180

Battery-powered portable sound system, 120 W, without built-in sources

Code : H9978



Power rating: 120 W (2 channels)
Loudspeaker: 10" loudspeaker + 1" driver
Free UHF microphone slot: 2
Free music player slot: One CD-RUN or USB-RUN slot, one RUN-K7 slot
Inputs: Two LINE in, two MIC in
Outputs: One MIX out, one speaker out
Battery: 2x 12 V / 4.5 Ah NP
Battery life: 6 hours (average)
Weight: 14 kg
Dimensions: 500 x 320 x 290 mm
Accessories supplied: Transport cover, built-in trolley, battery charger

Options: CD/USB/SD/MP3 reader + Bluetooth® + pitch and remote control, USB MP3 reader
Additional microphone receiver, additional hand-held UHF microphone, additional headset UHF microphone, cassette module

Recommended passive loudspeaker: PASSSPRINT

Power rating: 120 W (2 channels)
Loudspeaker: 10" loudspeaker + 1" driver
Microphone supplied: One hand-held UHF microphone, 16 selectable frequencies
4G-compatible frequency ranges: UHF 823 to 832 MHz and 863 to 865 MHz
Free UHF microphone slot: 1
Source: CD/USB/SD/MP3 reader + pitch + Bluetooth®
Free music player slot: No
Inputs: Two LINE in, two MIC in
Outputs: One MIX out, one speaker out
Battery: 2x 12 V / 4.5 Ah NP
Battery life: 6 hours (average)
Weight: 15 kg
Dimensions: 500 x 320 x 290 mm
Accessories supplied: Transport cover, built-in trolley, battery charger, infrared remote control

Options: Additional UHF receiver, additional hand-held UHF microphone, additional headset UHF microphone, cassette module

Recommended passive loudspeaker: PASSSPRINT

Power rating: 180 W (2 channels)
Loudspeaker: 10" loudspeaker + 1.5" driver
Microphone supplied: One hand-held UHF microphone, 16 selectable frequencies
4G-compatible frequency ranges: UHF 823 to 832 MHz and 863 to 865 MHz
Free UHF microphone slot: 1
Source: CD/USB/SD/MP3 reader + pitch + Bluetooth®
Free music player slot: No
Inputs: Two LINE in, two MIC in
Outputs: One MIX out, one speaker out
Battery: 2 x 12 V / 5 Ah NP
Battery life: 7 hours (average)
Weight: 17 kg
Dimensions: 500 x 320 x 360 mm
Accessories supplied: Transport cover, built-in trolley, battery charger, infrared remote control

Options: Additional UHF receiver, additional hand-held UHF microphone, additional headset UHF microphone

Recommended passive loudspeaker: PASSCROSS

Power rating: 180 W (2 channels)
Loudspeaker: 10" loudspeaker + 1.5" driver
Free UHF microphone slot: 2
Free music player slot: One CD-RUN or USB-RUN slot
Inputs: Two LINE in, two MIC in
Outputs: One MIX out, one speaker out
Battery: 2 x 12 V / 5 Ah NP
Battery life: 7 hours (average)
Weight: 16 kg
Dimensions: 500 x 320 x 360 mm
Accessories supplied: Transport cover, built-in trolley, battery charger

Options: CD/USB/SD/MP3 reader + Bluetooth® + pitch and infrared remote control
Additional microphone receiver, additional hand-held UHF microphone, headset UHF microphone

Recommended passive loudspeaker: PASSCROSS



CR-12AHEADset

Transmitter + headset microphone for CR12A-COMBO

Code : H10210



COV-CROSS

Transport cover for CROSSER loudspeakers

Code : H9985



COV-SPRINT

Transport cover for SPRINTER loudspeakers

Code : H9986



Compatible with the CR12A-COMBO portable sound system
16 selectable frequencies (823-832 and 863-865 MHz) - 10 mW
Type: Cardioid condenser microphone
Frequency response: 70 - 18 kHz

PORTABLE SOUND SYSTEMS



JOGGER60

Battery-powered portable sound system, 60 W, with USB/SD reader, one UHF microphone and one wired microphone

Code : H9894



Power rating: 60 W (2-way)
Loudspeaker: 5" loudspeaker + 1" driver
Microphones supplied: One wired microphone and one hand-held UHF microphone, 16 selectable frequencies
New 4G-compatible frequency ranges: UHF 823 to 832 MHz and 863 to 865 MHz
Source: USB/SD/MP3 reader
Inputs: One LINE input on 3.5 mm stereo jack, one MIC input on 6.35 mm jack
Outputs: One Mix output, LINE level, on 3.5 mm jack
Battery: 1x Lithium 14.4 V 2.6 Ah
Battery life: 4 hours (average)
Weight: 2.9 kg
Dimensions: 290 x 160 x 210 mm
Accessories supplied: carrying bag, lithium battery, mains adapter, infrared remote control

Options: Additional battery, external battery charger



JOGGER50

Battery-powered portable sound system, 50 W, with USB reader, one hand-held UHF microphone and carrying bag

Code : H9587



Power rating: 50 W
Loudspeaker: 5" speaker
Microphones supplied: One wired microphone and one hand-held UHF microphone, 16 selectable frequencies
New 4G-compatible frequency ranges: UHF 823 to 832 MHz and 863 to 865 MHz
Source: USB/MP3 reader
Inputs: One LINE input on 3.5 mm stereo jack, one MIC input on 6.35 mm jack
Outputs: One Mix output, LINE level, on 3.5 mm jack
Battery: 1x Lithium 14.4 V 2.6 Ah
Battery life: 4 hours (average)
Weight: 2.2 kg
Dimensions: 290 x 160 x 210 mm
Accessories supplied: carrying bag, lithium battery, mains adapter

Options: Additional battery, external battery charger



LTPOW

External charger for 260 mA lithium batteries, for JOGGER systems

Code : H9591



LT2600

260 mA lithium battery for JOGGER systems

Code : H9592



JOGGER60 in carrying bag supplied, with remote control and hand-held microphone included



PASSPRINT

120 W passive loudspeaker The ideal match for the SPRINTER

Code : H9983



Power rating: 120 W (2-way)
Loudspeaker: 10" loudspeaker + 1" driver
Supplied with a protective cover



PASSCROSS

180 W passive loudspeaker The ideal match for the CROSSER

Code : H9984



Power rating: 180 W (2-way)
Loudspeaker: 10" loudspeaker + 1.5" driver
Supplied with a protective cover



RECEPT-MOD16

Slot-in UHF receiver module

Code : H9979



Slot-in UHF receiver in for EMEA-HAND and EMEA-HEAD
16 selectable frequencies (823-832 and 863-865 MHz) - 10 mW
Compatible with RUNNER, SPRINTER and CROSSER



EMET-HAND

Hand-held microphone UHF transmitter

Code : H9980



Dynamic hand-held UHF microphone
16 selectable frequencies (823-832 and 863-865 MHz) - 10 mW
Uses two 1.5 V AA batteries (not supplied)
Compatible with RUNNER, SPRINTER, CROSSER and JOGGER



EMET-HEAD

Headset microphone with Pocket UHF transmitter

Code : H9981



Unidirectional headset condenser microphone + pocket UHF transmitter
16 selectable frequencies (823-832 and 863-865 MHz) - 10 mW
Uses two 1.5 V AA batteries (not supplied)
Compatible with RUNNER, SPRINTER, CROSSER and JOGGER



USB-RUN

USB reader for double slot

Code : H9982



Reads MP3 and WMA files
Compatible with RUNNER, SPRINTER and CROSSER



CD-RUN BT

CD/USB/SD and Bluetooth module

Code : H10184



CD, USB flash drive and SD card reader
Bluetooth® V2.0 AVRCP
Reads MP3 and WMA files
Infrared remote control
Compatible with RUNNER, SPRINTER and CROSSER



RUN-K7

Cassette player/recorder module for SPRINTER only

Code : H8206



Player with logic controls
Autoreverse play and recording
Adjustable pitch
Digital counter for locating recordings



PORTABLE SOUND SYSTEMS



PPA-101

Portable sound system, 50 W, with BT, FM, USB/SD reader and two UHF microphones; supplied without battery

Code : B00195



Power rating: 50 W (2-way)
Loudspeaker: 10" loudspeaker + 1" driver
Microphone supplied: One hand-held UHF microphone (863.35 MHz) + one headset microphone with Pocket UHF transmitter (864.80MHz)
Source: USB/SD reader + Bluetooth® + FM tuner
Inputs: One LINE input on 3.5 mm stereo jack, RCA or XLR, one MIC input on combined XLR/jack
Outputs: 1 LINE level on XLR
Battery: 1x 12 V 7 Ah (optional - code B00198)
Battery life: 6 hours (average)
Weight: 15.5 kg without battery
Dimensions: 550 x 325 x 280 mm
Accessories supplied: Built-in trolley, 12V car power cable

Options:
TOURING BAG-PPA-101 (protective cover)



PPA-121

Powerful professional portable speaker with USB/SD reader, FM, one LINE and two MIC inputs

Code : B00191



Power rating: 250 W (2-way)
Loudspeaker: 12" loudspeaker + 1.35" driver
Microphone supplied: No
Source: USB/SDHC reader + FM tuner
Inputs: One LINE input on RCA/XLR, two MIC inputs on XLR/jack
Outputs: 1 LINE level on XL
Battery: No
Weight: 15 kg
Dimensions: 580 x 372 x 315 mm
Accessories included: Infrared remote control



Bora Bora

60 W portable outdoor speaker, IPX5

Code : H10174



Power rating: 60 W (2-way)
Loudspeaker: One 5.25" speaker + four 2" speakers
Bluetooth V4.0 AVRCP, CSR compression, APT-X, NFC pairing
Inputs: One LINE input on 3.5 mm stereo jack
Controls on top: Standby, Volume + and -, battery level display
Battery: 1x Lithium 14.8 V 2600 mA
Battery life: 8 hours (average)
Weight: 2.9 kg
Dimensions: Diameter 195 / Height 370 mm
Ingress protection: IPX5 (weather-resistant)
Accessories supplied: mains battery charger, 3.5 mm jack/3.5 mm jack stereo lead



Hand-held UHF microphone for PPA-101 (863.35 MHz)

Code : B00197



Battery for PPA-101

12 V, 7 Ah lead-acid battery

Code : B00198



TOURING BAG - PPA-101

Protective bag for PPA-101

Code : B00598





COMMERCIAL AUDIO

BROADCASTING
AMPLIFIERS
MULTI SOURCE PLAYERS
HEARING LOOP SYSTEMS

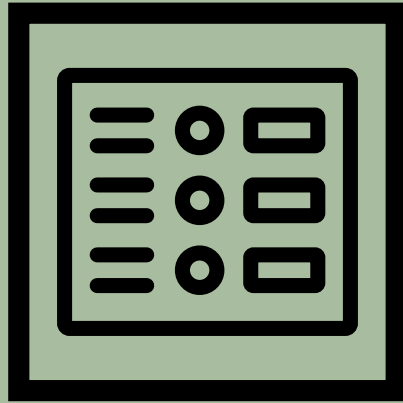

BROADCASTING

The time of the austere public address is over.

The name "Commercial Audio" is becoming more important for AUDIOPHONY PA.

Nowadays, these ranges are installed for their sound quality in chic and trendy places, but also in domestic settings. Their faithful reproduction of sound is one of the most important points, combined with aesthetics and simplicity.

AUDIOPHONY PA Commercial Audio, of course.

With the "Commercial Audio" range, you have a commercial broadcasting medium in shops, bars, public areas, etc.

Good sound quality is a distinct advantage. This is without mentioning our know-how in professional and institutional areas, with a range of easy-to-use products, capable of easing all your indoor, as well as outdoor, constraints.

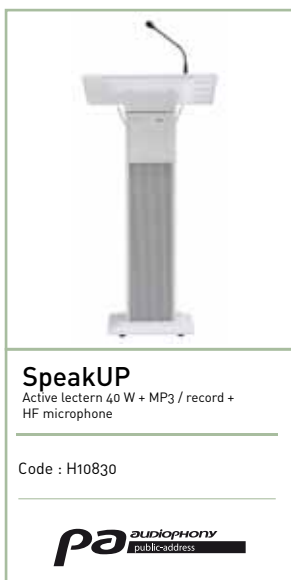

Amplified column lectern with VHF mic.
Built-in amplifier 40 W RMS.
Comes with 1 gooseneck microphone and 1 VHF hand-held microphone with in-built receiver.
1 MP3 reader/recorder module:
USB/SD/MMC
1 XLR microphone input.
1 RCA auxiliary input.
3 full-range loudspeakers.
Frequency response: 100 Hz – 16 kHz
1 recording output or 0dB line (6.35 mm jack).
Power: 240 V 50/60 Hz
Dimensions: 1140 x 580 x 420 mm
Weight: 17.2 kg



Power outputs : 45W
Voltage : 100 V
Components : 6.5" x1.3" x1"
Sensitivity (1W/1m): 86 dB, +/-2dB
Frequency response : 80-10 000 Hz
Material : Aluminium (Heavy damage proof finish)
Waterproof level : IP66
Dimensions : 240 mm [diam] x 440 mm
Weight : 6 Kg



Power outputs : 45W
Voltage : 100 V
Components : 6.5" x1"
Sensitivity (1W/1m): 88 dB, +/-2dB
Frequency response : 80-16 000 Hz
Material : Aluminium (Heavy damage proof finish)
Waterproof level : IP66
Dimensions : 250x360x420 mm
Weight : 7 Kg

NEW



WHITE FINISHING



JAVA315b (1 pair)
Tropicalized speaker 6" 100V 7.5-60W/8 Ohms-white

Code : H10921



NEW

WHITE FINISHING



JAVA315w (1 pair)
Tropicalized speaker 100V 7.5/15W/16 Ohms - white

Code : H10922



NEW





JAVA530b (1 pair)
Tropicalized speaker 100V 15-30W/16 Ohms - black

Code : H10923



NEW

WHITE FINISHING



JAVA530w (1 pair)
Tropicalized speaker 100V 15-30W/16 Ohms - white

Code : H10924



Power outputs : 7,5 / 15 W
Voltage : 100 V 16 Ohms
Components : 3" + 1"
Sensitivity (1W/1m): 90 dB, +/-3dB
Frequency response : 90 - 20 000 Hz
Material : Plastic enclosure and aluminium grille
Holding : Wallmount bracket
Connectors : Waterproof cable on gland IP55
Power rotary knob : 15W 16Ω // 7,5 / 15 W 100V
Dimensions : 112x 158 x 160 (H) mm
Weight : 0,9 Kg

Power outputs : 7,5 / 15 W
Voltage : 100 V 16 Ohms
Components : 3" + 1"
Sensitivity (1W/1m): 90 dB, +/-3dB
Frequency response : 90 - 20 000 Hz
Material : Plastic enclosure and aluminium grille
Holding : Wallmount bracket
Connectors : Waterproof cable on gland IP55
Power rotary knob : 15W 16Ω // 7,5 / 15 W 100V
Dimensions : 112x 158 x 160 (H) mm
Weight : 0,9 Kg

Power outputs : 15 / 30 W
Voltage : 100 V 16 Ohms
Components : 5" + 1"
Sensitivity (1W/1m): 88 dB, +/-3dB
Frequency response : 60 - 20 000 Hz
Material : Plastic enclosure and aluminium grille
Holding : Wallmount bracket
Connectors : Waterproof cable on gland IP55
Power rotary knob : 30W 16Ω // 15 / 30 W 100V
Dimensions : 178x 236 x 255 (H) mm
Weight : 2,38 Kg

Power outputs : 15 / 30 W
Voltage : 100 V 16 Ohms
Components : 5" + 1"
Sensitivity (1W/1m): 88 dB, +/-3dB
Frequency response : 60 - 20 000 Hz
Material : Plastic enclosure and aluminium grille
Holding : Wallmount bracket
Connectors : Waterproof cable on gland IP55
Power rotary knob : 30W 16Ω // 15 / 30 W 100V
Dimensions : 178x 236 x 255 (H) mm
Weight : 2,38 Kg



Borneo660b
Tropicalised installation speaker 60 Watts 2-way - 8 Ohms/100 V - Black

Code : H9920





Borneo660w
Tropicalised installation speaker 60 Watts 2-way - 8 Ohms/100 V - White

Code : H9911



Power rating: 60 W RMS
Available power:
60 W/20 W/15 W/10 W/5 W
8 Ohms/100 V
Tweeter: 1 inch
Woofers: 6.5 inch
Frequency response: 45 Hz - 20 kHz
Sensitivity (1 W @ 1 m): 89 dB
Attachment: swivel bracket
Humidity-resistant tropicalised speaker.
Dimensions: 340 x 220 x 200 mm
Net weight: 3.8 kg
Unit price - Sold by 2pcs

Power rating: 60 W RMS
Available power:
60 W/20 W/15 W/10 W/5 W
8 Ohms/100 V
Tweeter: 1 inch
Woofers: 6.5 inch
Frequency response: 45 Hz - 20 kHz
Sensitivity (1 W @ 1 m): 89 dB
Attachment: swivel bracket
Humidity-resistant tropicalised speaker.
Dimensions: 340 x 220 x 200 mm
Net weight: 3.8 kg
Unit price - Sold by 2pcs

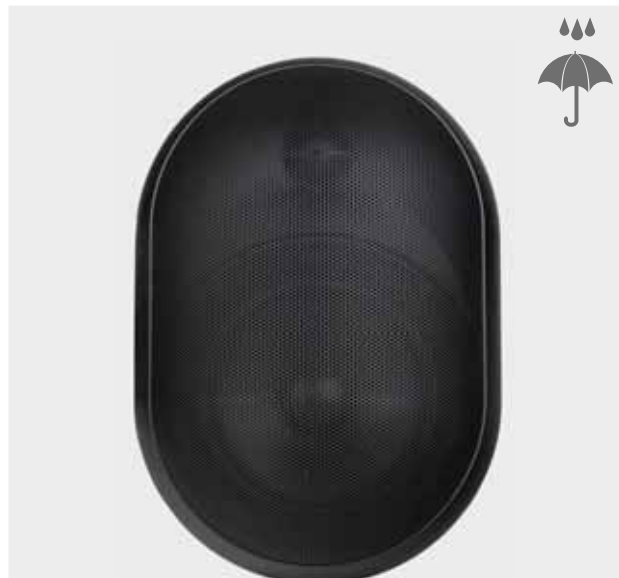

The JAVA, EHP-IP and BORNEO speakers are particularly suitable for their sound qualities which make them ideal tools for diffusing ambient music. The tropicalized finish allows them to be used on terraces as long as they are protected from direct exposure to rain.

BROADCASTING



EHP880B

Installation speaker 80 Watts
2-way - 8 Ohms/70 V/100 V - Black

Code : H10212



Power rating: 80 W RMS
Available power: 80 W/40 W/20 W at 100 V - 40 W/20 W/10 W at 70 V
80 W at 8 Ohms
Tweeter: 1"
Woofer: 8"
Frequency response: 70 Hz - 18 kHz
Sensitivity (1 W @ 1 m): 92 dB
Attachment: swivel bracket
Dimensions: 410 x 290 x 240 mm
Net weight: 8 kg
Unit price - Sold by 2pcs



EHP880W

Installation speaker 80 Watts
2-way - 8 Ohms/70 V/100 V - White

Code : H10213



Power rating: 80 W RMS
Available power: 80 W/40 W/20 W at 100 V - 40 W/20 W/10 W at 70 V
80 W at 8 Ohms
Tweeter: 1"
Woofer: 8"
Frequency response: 70 Hz - 18 kHz
Sensitivity (1 W @ 1 m): 92 dB
Attachment: swivel bracket
Dimensions: 410 x 290 x 240 mm
Net weight: 8 kg
Unit price - Sold by 2pcs



EHP660IPb (1 pair)

Tropicalized speaker 6" 100V 7.5-60W/8 Ohms-black

Code : H10919



Power outputs : 7,5 / 15 / 30 / 60 W
Voltage : 100 V 8 Ohms
Components : 6,5" + 1"
Sensitivity (1W/1m): 90 dB, +/-3dB
Frequency response : 70 - 20 000 Hz
Material : Plastic enclosure and aluminium grille
Holding : Wallmount bracket
Connectors : Waterproof cable on gland IP55
Power rotary knob : 60W 8Ω // 7,5 / 15 / 30 / 60 W 100V
Dimensions : 214x178 x 329 (H) mm
Weight : 4,7 Kg



EHP660IPw (1 pair)

Tropicalized speaker 6" 100V 7.5-60W/8 Ohms-white

Code : H10920



Power outputs : 7,5 / 15 / 30 / 60 W
Voltage : 100 V 8 Ohms
Components : 6,5" + 1"
Sensitivity (1W/1m): 90 dB, +/-3dB
Frequency response : 70 - 20 000 Hz
Material : Plastic enclosure and aluminium grille
Holding : Wallmount bracket
Connectors : Waterproof cable on gland IP55
Power rotary knob : 60W 8Ω // 7,5 / 15 / 30 / 60 W 100V
Dimensions : 214x178 x 329 (H) mm
Weight : 4,7 Kg



EHP520b

Installation speaker 40 Watts
2-way - 8 Ohms/70 V/100 V - Black

Code : H9763



Power rating: 40 W RMS
Available power: 40 W/20 W/10 W at 100 V - 20 W/10 W/5 W at 70 V
40 W at 8 Ohms
Tweeter: 1 inch
Woofer: 5 inch
Frequency response: 80 Hz - 18 kHz
Sensitivity (1 W @ 1 m): 89 dB
Attachment: swivel bracket
Dimensions: 270 x 187 x 165 mm
Net weight: 3,4 kg
Unit price - Sold by 2pcs



EHP520w

Installation speaker 40 Watts
2-way - 8 Ohms/70 V/100 V - White

Code : H9762



Power rating: 40 W RMS
Available power: 40 W/20 W/10 W at 100 V - 20 W/10 W/5 W at 70 V
40 W at 8 Ohms
Tweeter: 1"
Woofer: 5"
Frequency response: 80 Hz - 18 kHz
Sensitivity (1 W @ 1 m): 89 dB
Attachment: swivel bracket
Dimensions: 270 x 187 x 165 mm
Net weight: 3,4 kg
Unit price - Sold by 2pcs



EHP420IPb

Tropicalized speaker 4" 100V 2-20W/8 Ohms-black

Code : H10917



Power outputs : 2,5 / 5 / 10 / 20 W
Voltage : 100 V 8 Ohms
Components : 4" + 1"
Sensitivity (1W/1m): 88 dB, +/-3dB
Frequency response : 90-18 000 Hz
Material : Plastic enclosure and aluminium grille
Holding : Lyre d'accroche murale
Connectors : Câble sur presse étoupe étanche IP55
Power rotary knob : 20W 8Ω // 2,5 / 5 / 10 / 20 W 100V
Dimensions : 158x129 x 238 (H) mm
Weight : 2,4 Kg



EHP420IPw

Tropicalized speaker 4" 100V 2-20W/8 Ohms-white

Code : H10918



Puissances : 2,5 / 5 / 10 / 20 W
Alimentation : 100 V 8 Ohms
Composants : 4" + 1"
Sensibilité (1W/1m) : 88 dB, +/-3dB
Réponse en fréquence : 90-18 000 Hz
Construction : Corps en ABS blanc et grille métallique
Accroche : Lyre d'accroche murale
Connections : Câble sur presse étoupe étanche IP55
Sélecteur de puissance : 20W 8Ω // 2,5 / 5 / 10 / 20 W 100V
Dimensions : 158x129 x 238 (H) mm
Poids : 2,4 Kg



EHP410b

Installation speaker 20 Watts
2-way - 8 Ohms/70V/100V - Black

Code : H9761



EHP410w

Installation speaker 20 Watts
2-way - 8 Ohms/70 V/100 V - White

Code : H9760



ROT45b

Black swivel ball mount for speakers
EHP410b and EHP520b - 1 piece

Code : H9824



ROT45w

White swivel ball mount for speakers
EHP410w and EHP520w - 1 piece

Code : H9825



Power rating: 20 W RMS
Available power: 20 W/10 W/5 W at 100 V
- 10 W/5 W/2.5 W at 70 V
20 W at 8 Ohms
Tweeter: 1"
Woofer: 4"
Frequency response: 80 Hz - 18 kHz
Sensitivity (1 W @ 1 m): 89 dB
Attachment: swivel bracket
Dimensions: 240 x 170 x 160 mm
Net weight: 1.45 kg
Unit price - Sold by 2pcs

Power rating: 20 W RMS
Available power: 20 W/10 W/5 W at 100 V
- 10 W/5 W/2.5 W at 70 V
20 W at 8 Ohms
Tweeter: 1"
Woofer: 4"
Frequency response: 80 Hz - 18 kHz
Sensitivity (1 W @ 1 m): 89 dB
Attachment: swivel bracket
Dimensions: 240 x 170 x 160 mm
Net weight: 1.45 kg
Unit price - Sold by 2pcs



Transformer 20W Input 2.5/5/10/20w in
100v out 80hms

Code : H10975



60W Transformer Input 7.5/15/30/60w in
100v out 80hms

Code : H10976



Transform your speakers
into 100 V speakers

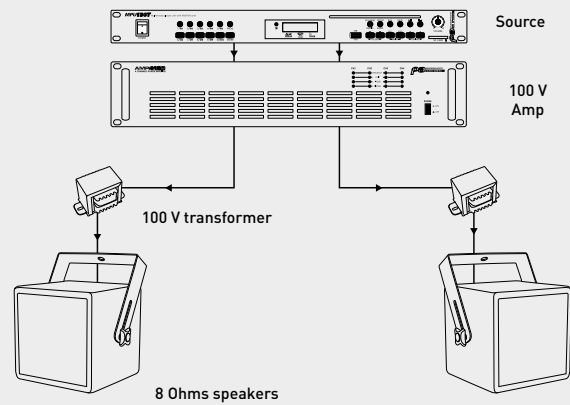

BROADCASTING



K-50/Black (pair)
Installation speaker 50 Watts
2-way - 8 Ohms - Black

Code : B00668



Power rating: 50 W RMS
Available power:
50 W at 8 Ohms
Tweeter: 1 inch
Woofer: 5.25 inch
Frequency response: 55 Hz - 20 kHz
Attachment: swivel bracket
Dimensions: 238 x 180 x 150 mm
Net weight: 5 kg
Price for the pair



K-50/White (pair)
Installation speaker 50 Watts
2-way - 8 Ohms - White

Code : B00669



Power rating: 50 W RMS
Available power:
50 W at 8 Ohms
Tweeter: 1 inch
Woofer: 5.25 inch
Frequency response: 55 Hz - 20 kHz
Attachment: swivel bracket
Dimensions: 238 x 180 x 150 mm
Net weight: 5 kg
Price for the pair



K-30/Black (pair)
Installation speaker 40 Watts
2-way - 8 Ohms - Black

Code : B00672



Power rating: 40 W RMS
Available power:
40 W at 8 Ohms
Tweeter: 1 inch
Woofer: 3.5 inch
Frequency response: 65 Hz - 20 kHz
Attachment: swivel bracket
Dimensions: 170 x 130 x 105 mm
Net weight: 2.5 kg
Price for the pair



K-30/White (pair)
Installation speaker 40 Watts
2-way - 8 Ohms - White

Code : B00673



Power rating: 40 W RMS
Available power:
40 W at 8 Ohms
Tweeter: 1 inch
Woofer: 3.5 inch
Frequency response: 65 Hz - 20 kHz
Attachment: swivel bracket
Dimensions: 170 x 130 x 105 mm
Net weight: 2.5 kg
Price for the pair



K-80/Black (pair)
Installation speaker 85 Watts
2-way - 8 Ohms - Black

Code : B00670



Power rating: 85 W RMS
Available power:
85 W at 8 Ohms
Tweeter: 1 inch
Woofer: 8 inch
Frequency response: 35 Hz - 20 kHz
Attachment: swivel bracket
Dimensions: 335 x 270 x 210 mm
Net weight: 12.8 kg
Price for the pair



K-80/White (pair)
Installation speaker 85 Watts
2-way - 8 Ohms - White

Code : B00671



Power rating: 85 W RMS
Available power:
85 W at 8 Ohms
Tweeter: 1 inch
Woofer: 8 inch
Frequency response: 35 Hz - 20 kHz
Attachment: swivel bracket
Dimensions: 335 x 270 x 210 mm
Net weight: 12.8 kg
Price for the pair



OHO-350b (pair)
Spherical satellite speaker 50 W RMS
2-way - Black

Code : H10125



Power rating: 50 W RMS
Frequency response: 100 Hz - 25 KHz
Sensitivity (1 W @ 1 m): 89 dB
Nominal impedance: 8 Ohms
Tweeter: 1 inch
Woofer: 3 inch
Connector: Terminal block integrated in the magneticbracke
Dimensions: 99 mm diameter
Weight: 0.7 kg
Price for the pair



OHO-350w (pair)
Spherical satellite speaker 50 W RMS
2-way - White

Code : H10124



Power rating: 50 W RMS
Frequency response: 100 Hz - 25 KHz
Sensitivity (1 W @ 1 m): 89 dB
Nominal impedance: 8 Ohms
Tweeter: 1 inch
Woofer: 3 inch
Connector: Terminal block integrated in the magneticbracke
Dimensions: 99 mm diameter
Weight: 0.7 kg
Price for the pair



MIO-Sat440b (pair)

Wall speaker on adjustable mount
2-way - 8 Ohms - 40 W

Code : H10154



Power rating: 40 W RMS
Frequency response: 120 Hz - 16 KHz
Maximum SPL (@ 1 m): 116 dB
Nominal impedance: 8 Ohms
Tweeter: 1 inch
Woofer: 4 inch
Connector: Terminal block at rear
Dimensions: 225 x 150 x 170 mm
Weight: 2.6 kg
Price for the pair



MIO-Sat225b (pair)

Wall speaker on adjustable mount, Hi-Fi
speaker - 8 Ohms - 25 W

Code : H10150



Power rating: 25 W RMS
Frequency response: 200 Hz - 15 KHz
Maximum SPL (@ 1 m): 110 dB
Nominal impedance: 8 Ohms
Speaker: 2 x 2.75 inches
Connector: Terminal block integrated
in bracket
Dimensions: 90 x 136 x 180 mm
Weight: 0.950 kg
Price for the pair



MIO-Sub8150b

Active sub with active satellite output
150 W + 2 x 40 W

Code : H10153



ACTIVE SUB:
Power rating: 150 W
Frequency response: 52 - 200 Hz
Maximum SPL (@ 1 m): 120 dB
Woofer: 8 inch
Dimensions: 360 x 250 x 250 mm
Weight: 10.3 kg
AMPLIFICATION:
Low level: 1 x 150 W
Mid/high level: 2 x 40 W RMS / 4 Ohms
Sub phase switch 0/180
Sub and Master adjustable levels.
Connectors: 2 x XLR/Jack Combo and
2 x RCA line input
Terminal block for satellites



MIO-Sub6100b

Active sub with active satellite output
100 W + 2 x 25 W

Code : H10149



ACTIVE SUB:
Power rating: 100 W
Frequency response: 50 - 200 Hz
Maximum SPL (@ 1 m): 112 dB
Woofer: 6.5 inch
Dimensions: 320 x 240 x 200 mm
Weight: 8.5 kg
AMPLIFICATION:
Low level: 1 x 100 W
Mid/high level: 2 x 25 W RMS / 4 Ohms
Sub phase switch 0/180
Sub and Master adjustable levels.
Connectors: 2 x XLR/Jack Combo and
2 x RCA line input
Terminal block for satellites



OH0-Systema1b

Amplified triphonic system 150 W lows -
2 x 40 W highs

Code : H10156



This amplified triphonic system is
consists of:
1 x MIO-Sub8150b
2 x OH0-350b



MIO-Systema2b

Amplified triphonic system 150 W lows -
2 x 40 W highs

Code : H10152



This amplified triphonic system is
consists of:
1 x MIO-Sub8150b
2 x MIO-Sat440b



MIO-Systema1b

Amplified triphonic system 100 W lows -
2 x 25 W highs

Code : H10148



This amplified triphonic system is
consists of:
1 x MIO-Sub6100b
2 x MIO-Sat225b



Rear view of MIO-Sub8150b



BROADCASTING



CHF860

Hi-Fi ceiling recessed speaker 60 Watts
2-way - 8 Ohms

Code : H9909



2-way speaker
Power rating: 60 W RMS
Impedance: 8 Ohms
Tweeter: 1 inch
Woofer: 6.5 inch
Frequency response: 40 Hz – 20 kHz
Sensitivity >90dB
External dimensions (diameter and depth):
280 x 180 mm
Drilling diameter: 247 mm
Net weight: 2.48 kg



CHF835

2-way ceiling light 35W 8inch 80hms
80hms

Code : H10965



Power outputs : 10W
Impedance: 8 Ohms
Components - 8" + 1"
Sensitivity (1W/1m): 103 dB, +/-2dB
Frequency response : 90-18 000 Hz
Material : white plastic enclosure and
magnetic grille
Holding : 4 mounting clamp
Dimensions : 190 mm (diam) x 105 mm
Weight : 2 Kg



CHP6A-Bset

Ceiling lights 6.5 inches active 2x10w
BT 4.0

Code : H10933



Power outputs : 10W
Impedance: 8 Ohms
Components : 6.5"
Sensitivity (1W/1m): 90 dB, +/-2dB
Frequency response : 110-15 000 Hz
Material : White plastic enclosure
Holding : 2 string grip
Connectors: Euro block
Bluetooth: 4.0
Dimensions : 190 mm (diam) x 105 mm
Weight : 1 Kg
Set of two ceiling speakers, one of which
is active (with Bluetooth® receiver) and
powers the other (passive).



CHP660

Ceiling recessed speaker
2-way - 60 W / 8 Ohms - 10 W / 100 V

Code : H9910



Power rating: 60 W RMS
Available power:
60 W at 8 Ohms
10 W / 5 W / 2.5 W / 1.25 W at 100 V
Tweeter: 1 inch
Woofer: 6.5 inch
Frequency response: 56 Hz – 20 kHz
Sensitivity (1 W @ 1 m): 90 dB
External dimensions (diameter and depth):
240 x 140 mm
Drilling diameter: 208 mm
Net weight: 1.75 kg

THE DISCREET HIFI

With the CHF860, you have speakers at your service, perfectly integrated without any acoustic compromise.

With absolute discretion, these models offer the same presence and the same sound fidelity than traditional models top-of-the-range.



HIGH-QUALITY VOICE AND MUSIC

The CHF835 ceiling speaker features a 2-way coaxial speaker producing a very pure sound even at low volume.

The tweeter is incredibly efficient at transmitting a clear vocal reproduction.





CHP630SQ
Square ceiling speaker 2-way 6" ABS white

Code : H10974



Power: 30W
Available power: 100 V 8 Ohms
Components: 5" + 0.5" + 0.5
Sensitivity (1W/1m): 89 dB, +/- 3dB
Frequency response: 90-20 000 Hz
Construction: White ABS body
Hook: 4 screwed tabs
Dimensions: 220 x 220 x 220 x 95 mm
Weight: 980 g



CHP620
Ceiling recessed speaker
2-way 20 W / 100 V

Code : H9757



Power rating: 20 W RMS
Available power:
20 W / 10 W at 100 V
Tweeter: 1.5 inch
Woofers: 6.5 inch
Frequency response: 85 Hz - 18 kHz
Sensitivity (1 W @ 1 m): 98 dB
External dimensions (diameter and depth):
233 x 118 mm
Drilling diameter: 200 mm
Net weight: 1.7 kg



CHP610
Ceiling recessed speaker
2-way 10 W / 100 V

Code : H9756



Power rating: 10 W RMS
Available power:
10 W / 5 W / 2.5 W at 100 V
Tweeter: 1.5 inch
Woofers: 6.5 inch
Frequency response: 56 Hz - 20 kHz
Sensitivity (1 W @ 1 m): 93 dB
External dimensions (diameter and depth):
230 x 90 mm
Drilling diameter: 200 mm
Net weight: 1.4 kg



CHP606
Ceiling recessed double cone speaker
6 W / 100 V

Code : H9755



Power rating: 6 W RMS
Available power:
6 W / 3 W at 100 V
Speaker: double cone 6.5 inches
Frequency response: 110 Hz - 13 kHz
Sensitivity (1 W @ 1 m): 90 dB
External dimensions (diameter and depth):
230 x 90 mm
Drilling diameter: 200 mm
Net weight: 0.9 kg



CHP520SQ
2-way square ceiling speaker 5" ABS white
100V 5/10/20W

Code : H10916



Power outputs: 5 / 10 / 20 W
Voltage: 100 V / 8 ohms
Components: 4" + 1/2"
Sensitivity (1W/1m): 89 dB, +/- 3dB
Frequency response: 90-18 000 Hz
Material: White plastic enclosure and metallic grille
Holding: 4 mouting clamp
Connectors: 4 contacts connector
Drill hole dimensions: 156 x 156 mm
Dimensions: 190 x 190 x 80 (H) mm
Weight: 1,3 Kg



CHP520
2-way ceiling speaker 5" 100V 5/10/20W

Code : H10914



Power outputs: 5 / 10 / 20 W
Voltage: 100 V / 8 ohms
Components: 5" loud-speaker
Sensitivity (1W/1m): 88 dB, +/- 3dB
Frequency response: 100-20 000 Hz
Material: Black plastic enclosure and white magnetic grille
Holding: 3 mouting clamp
Connectors: 4 contacts connector
Drill hole diameter: 180mm
Dimensions: 203(diam) x 85 (H) mm
Weight: 1.5 Kg



CHP506
Ceiling speaker 5" double speaker cone
ABS white 100V 3/6W

Code : H10912



Power outputs: 3 / 6 W
Voltage: 100 V
Components 5" loud-speaker
Sensitivity (1W/1m): 93 dB, +/- 3dB
Frequency response: 100-15 000 Hz
Material: Metallic grille and plastic enclosure
Holding: 2 string grip
Connectors: 3 contacts connector
Drill hole diameter: 145mm
Dimensions: 160(diam) x 54 (H) mm
Weight: 500 g

CHP630SQ

A high-quality sound in all circumstances



BROADCASTING



CHPsub

Ceiling recessed subwoofer
60 W / 8 Ohms – 60 W / 100 V

Code : H10533



Power rating: 60 W RMS
Available power:
60 W at 8 Ohms
60 W / 40 W / 20 W at 100 V
Frequency response: 80 Hz -200 Hz
Woofer: 8 inch
Sensitivity (1 W @ 1 m): 95 dB
Enclosed metal box
Integrated passive filter
External dimensions (diameter and depth):
295 x 215 mm
Drilling diameter: 265 mm
Net weight: 5 kg



SHP510

Suspended aluminium speaker IP55
10 W / 100 V

Code : H9758



Power rating: 10 W RMS
Available power:
10 W / 5 W / 2.5 W at 100 V
Frequency response: 150 Hz – 15 kHz
Speaker: 5 inch
Sensitivity (1 W @ 1 m): 90 dB
White aluminium body,
Ingress protection: IP55 (weather-resistant)
Dimensions (Ø x D): 138 x 205 mm
Weight: 2.2 kg



SHP820w

Suspended 2-way 8" diff. 360°-100V
5-20W-bl

Code : H10925



Power outputs : 5 / 10 / 20 W
Voltage : 100 V
Components : 8" + 1"
Sensitivity (1W/1m): 88 dB, +/-3dB
Frequency response : 130-15 000 Hz
Material : White plastic enclosure
Holding : 5 m slung cable
Connectors : Cable on gland
Dimensions : 254 mm (diam)
Weight : 2,2 kg



PHP510

Aluminium sound projector IP55
10 W / 100 V

Code : H9759



Power rating: 10 W RMS
Available power:
10 W / 5 W / 2.5 W at 100 V
Frequency response: 150 Hz – 14 kHz
Speaker: 5 inch
Sensitivity (1 W @ 1 m): 90 dB
White aluminium body,
Ingress protection: IP55 (weather-resistant)
Dimensions (Ø x D): 138 x 205 mm
Weight: 2.1 kg



PHP650

Sound projector IP55
50 W / 100 V

Code : H10211



Power rating: 50 W RMS
Available power:
50 W/25/12.5/9/4.5/2.6 at 100 V
Frequency response: 90 Hz – 20 kHz
Speaker: 6.5 inches and 1-inch
compression
Sensitivity (1 W @ 1 m): 99 dB
ABS body,
Ingress protection: IP55 (weather-resistant)
Dimensions: 363 x 253 x 310 mm
Weight: 3.9 kg



INTERIOR / EXTERIOR

The PHP650 speakers are also at ease indoors and outdoors. Their bodies are completely made of aluminium, allowing installation and continuous functioning, even when exposed to weather conditions. Thanks to their wide sound opening, they are perfect for use in big spaces

The columns are delivered with wall mounting brackets.

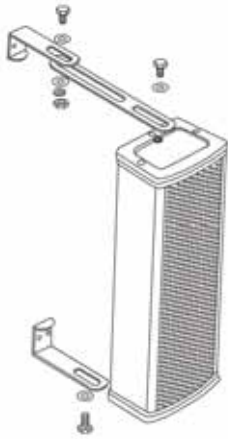

Aluminium speakers are designed to resist humidity. The wiring is mounted on a cable gland to ensure the waterproofing.

The multi-speaker system columns allows a diffusion very wide while reducing the vertical angle. This prevents echoes. The column is therefore the ideal tool for speeches in big spaces.



CLS220
2-speakers column
100 V - 10/20 W

Code : H10514



Power rating: 20 W RMS
Available power:
20 W / 10 W at 100 V
Speaker: 2 x 2.5 inches
Frequency response: 250 Hz -15 KHz
Sensitivity (1 W @ 1 m): 94 dB
Aluminium body and grill,
Ingress protection: IP44 (weather-resistant)
Dimensions: 104 x 73 x 262 mm
Weight: 1.4 kg



CLS440
4-speakers column
100 V - 20/40 W

Code : H10515



Power rating: 40 W RMS
Available power:
40 W / 20 W at 100 V
Speaker: 4 x 2.5 inches
Frequency response: 250 Hz -15 KHz
Sensitivity (1 W @ 1 m): 95 dB
Aluminium body and grill,
Ingress protection: IP44 (weather-resistant)
Dimensions: 104 x 73 x 402 mm
Weight: 1.94 kg



CLS660
6-speakers column
100 V - 30/60 W

Code : H10516



Power rating: 60 W RMS
Available power:
60 W / 30 W at 100 V
Speaker: 6 x 2.5 inches
Frequency response: 250 Hz -15 KHz
Sensitivity (1 W @ 1 m): 96 dB
Aluminium body and grill,
Ingress protection: IP44 (weather-resistant)
Dimensions: 104 x 73 x 550 mm
Weight: 2.6 kg



CLS880
8-speakers column
100 V - 40/80 W

Code : H10517



Power rating: 80 W RMS
Available power:
80 W / 40 W at 100 V
Speaker: 8 x 2.5 inches
Frequency response: 250 Hz -15 KHz
Sensitivity (1 W @ 1 m): 97 dB
Aluminium body and grill,
Ingress protection: IP44 (weather-resistant)
Dimensions: 104 x 73 x 690 mm
Weight: 3.34 kg

AMPLIFIERS

NEW



Bluetooth™

WALLKIT
WALLAMPmedia + ceiling lights set

Code : H10964



Wall amplifier set
WALLAMPmedia 2 x 10W with 2x 2-way ceiling speakers
240V power supply
Impedance: 8 Ohms
Components: 6.5" + 0.75" + 6.5
Sensitivity. (1W/1m) : 103 dB, +/-2dB
Frequency response: 90-18 000 Hz
Construction: Black ABS body and white magnetic metal grid
Hook: 2 legs. spring
Dimensions: 190 mm (diameter) x 105 mm
Weight: 1 Kg

NEW



Bluetooth™

WALLAMPmedia
Wall amplifier 2x10W SD/BT/Radio/AUX + line Out

Code : H10930



Power outputs: 2x10W
Impedance: 8 Ohms
Power supply: 240 V
Signal-to-noise ratio: 81 dB →81 dB
Output: Line output for external amplifier
Memory card capacity: 128 MB - 32GB
Audio format: MP3, WMA, WAV, AAC, FLAC
Bluetooth: 2.1+EDR
Dimensions: 86 x 86 x 86 x 38 mm

NEW



Bluetooth™

WALLAMPtouch
Wall amplifier 2x10W touch screen SD/BT/Radio/AUX

Code : H10931



Power ratings: 2x10W
Impedance: 8 Ohms
Power supply: 240 V
Frequency response: 20 - 20 000 kHz
Output: Line output for external amplifier
Port: SD, USB
Audio format: MP3, WMA, WAV, AAC, FLAC
Infrared remote control
Bluetooth: 4.0
Dimensions: 86 x 86 x 86 x 38 mm

NEW



Bluetooth™

WALLAMPpad
Wall amplifier 2x20W tact.SD/BT/AUX/DLNA/Airplay&App

Code : H10932



Power : 2X20W
Impedance: 8 Ohms
240V power supplies
Frequency response: 20 - 20 000 Hz
Aux output for an external amplifier
Port: SD/ RJ45
Sources: Bluetooth® / DLNA / Airplay / WIFI / Webradio / Network music / Application / Aux in
Dimensions: 172 x 86 x 45 mm



AMP480

1-way public address amplifier
1 x 480 W at 100 V

Code : H10512



1 mono input via Phoenix plug
1 100V output via Phoenix plug
1 line level link output via Phoenix plug
Channel volume adjustment
Flat/HPF channel switch
Output level display via 4 LED VU meters
Access to installer settings (via screwdriver)
Power supply: 230 V 50/60 Hz
Frequency response: 50 Hz - 15 kHz
T.H.D (1 kHz nominal power): 0.1%
Dimensions: 380 x 088 x 482 mm
19-inch rackable, Height: 2 units
Weight: 6.6 kg



- Very high power 480 W at 100 V
- Switched-mode power supply
- Settings accessible only at the back



★★★★★



★★★★★



★★★★★



★★★★★

**AMP4120**4-way public address amplifier
4 x 120 W at 100 V

Code : H10511



4 mono inputs via Phoenix plug
4 100 V outputs via Phoenix plug
4 line level link outputs via Phoenix plug
Volume adjustment for each channel,
Flat/HPF switch for each channel
Output level display for each channel via
4 LED VU meters
Access to installer settings
Power supply: 230 V 50/60 Hz
Frequency response: 50 Hz - 15 kHz
T.H.D (1 kHz nominal power): 0.1%
Dimensions: 380 x 088 x 482 mm
19-inch rackable, Height: 2 units
Weight: 7.2kg

AMP42404-way public address amplifier
4 x 240 W at 100 V

Code : H10506



4 mono inputs via Phoenix plug
4 100 V outputs via Phoenix plug
4 line level link outputs via Phoenix plug
Volume adjustment for each channel,
Flat/HPF switch for each channel
Output level display for each channel via
4 LED VU meters
Access to installer settings
Power supply: 230 V 50/60 Hz
Frequency response: 50 Hz - 15 kHz
T.H.D (1 kHz nominal power): 0.1%
Dimensions: 380 x 088 x 482 mm
19-inch rackable, Height: 2 units
Weight: 7.5 kg



★★★★★



★★★★★

**AMP120**Public address amplifier 120W -
8 Ohms/70/100 V

Code : H9903



RMS power: 120 W
Output levels / Impedance:
- 100 V (83 Ohms)
- 70 V (42 Ohms)
- 4 Ohms (21.9 V)
Balanced XLR input/output
Power output on Phoenix plug
Frequency response: 70 Hz - 18 KHz
T.H.D (1 KHz): <1%
400 Hz High-pass filter
Power supply: 230 V 50/60 Hz
- DC24V (safe power)
Dimensions: 482 x 88 x 330 mm
19-inch rackable, Height: 2 units
Net weight: 11.6 Kg

AMP240Public address amplifier 240 W -
8 Ohms/70/100 V

Code : H9904



RMS power: 240 W
Output levels / Impedance:
- 100 V (42 Ohms)
- 70 V (21 Ohms)
- 4 Ohms (31 V)
Balanced XLR input/output
Power output on Phoenix plug
Frequency response: 70 Hz - 18 KHz
T.H.D (1 KHz): <1%
400 Hz High-pass filter
Power supply: 230 V 50/60 Hz
- DC24V (safe power)
Dimensions: 482 x 88 x 330 mm
19-inch rackable, Height: 2 units
Net weight: 13.8 Kg

**MIC-DESK**Announcement microphone fitted with
'push to talk' system

Code : H9748



Dynamic capsule
Frequency response: 40 Hz to 16 kHz
Sensitivity: -43 dB
Impedance: 200 Ohms
Comes with:
1 XLR 5-pin female / DIN 5-pin male
5 m cable.
1 XLR 5-pin female / 6.35 mm mono
Jack male 3 m cable.
Dimensions: 430 x 200 x 75 mm
Weight: 1.05 kg

**REG60**

Remote volume adjuster in wall box - 60 W

Code : H9753



Power: 60 W / 100 V
24 V Priority input
Settings: Off/-17 dB/-11 dB/-4.5 dB/0 dB
Frequency response: 20 Hz - 20 kHz
White ABS body
Fixing: REG-BOX (optional)
Connection: 6-pin connector
(IN+ IN- / OUT+ OUT- / 0 V 24 V)
Dimensions: 86 x 86 x 70 mm
Weight: 0.250 kg.

**REG-BOX**

Recessed box for wall adjuster REG60

Code : H9754



AMPLIFIERS



COMBO240

Multi-zone combined mixer amplifier line
100V combo 5 zones 6 inputs - 240W

Code : H9751



All-in-one 240W system with multimedia option
6-input mixer
5 independent simultaneous zones
7-band graphic equalizer
Paging, siren and chime control
Priority mode and Phantom power on channels 1 and 2
5-pin DIN input microphone 1
XLR line or microphone input on channels 2 to 5
RCA input on channel 6
Paging input on Phoenix plug
AMP IN and PRE-AMP OUT connections
LINK IN and LINK OUT connections
100 V / 8 to 4 Ohms outputs on the terminal block
Dimensions: 420 x 320 x 88 mm
19-inch rackable
Weight: 10.8 kg

Optional:

MOD1

USB/SD reader module and AM/FM
Tuner receiver for COMBO240



- All-in-one system with multimedia option
- 6-input mixer
- 5 Switchable zones
- 7-band graphic equaliser
- Paging and chime control
- 19-inch rackable
- Removable brackets



★★★★★



★★★★★



COMBO130

Multimedia combined mixer/amplifier/
reader line 200V 130W Tuner and USB
reader

Code : H9750



130W all-in-one system
5-input mixer:
3-way microphone - Aux1/MP3/TUNER
-Aux2
Low and high settings
Mp3 and Tuner player controls
Chime activation
Output level VU meter
6.35 input jack for microphones 1 and 2
RCA input for AUX1 and AUX2
OUT output on RCA
Connections for FM and AM antennas
100 V / 16 to 4 Ohms outputs on the terminal block
Tuner receiver: AM / FM
Autoscan, Manual scan
FM frequencies: 87.5 MHz - 108 MHz
AM frequencies: 522 kHz - 1620 kHz
USB reader: mp3 files
Functions: read, search, programming
time setting
Power: 220 V 50-60 Hz
Consumption: 175 W
Dimensions: 483 x 89 x 366 mm
Net weight: 11.36 kg



- All-in-one system
- 5-input mixer
- Push-button chimer
- 19-inch rackable
- 70 V/100 V amplified output or low impedance
- 1 front-panel microphone input



★★★★★



★★★★★



COMBO60

Multimedia combined mixer/amplifier/reader
line 100V 60W Tuner and USB reader

Code : H9749



60W compact all-in-one system
3-input mixer:
2-way microphone - Aux1/MP3/TUNER
Low, mid and high settings
Mp3 and Tuner player controls
Output level VU meter
6.35 input jack for microphones
AUX input and CD on RCA
Waiting music input on Phoenix plug
Paging input on Phoenix plug
Connections for FM and AM antennas
100 V / 16 / 8 / 4 Ohms outputs on the terminal block
Tuner receiver: AM / FM
Autoscan, Manual scan
FM frequencies: 87,5 MHz - 108 MHz
AM frequencies: 522 kHz - 1620 kHz
USB reader: mp3 files
Functions: read, search, programming
time setting
Power: 220 V 50-60 Hz
Consumption: 175 W
Dimensions: 90 x 270 x 260 mm
Net weight: 5 kg



- Compact all-in-one system
- Integrated USB reader and tuner
- Microphone input and 2 line inputs
- Paging and waiting music compatible
- Priority safety output
- 3-band equalizer



MOD1

USB/SD reader module and AM/FM Tuner
receiver for COMBO240

Code : H9752



Tuner receiver: AM / FM
Autoscan, Manual scan
FM frequencies: 87,5 MHz - 108 MHz
AM frequencies: 522 kHz - 1620 kHz
USB reader: mp3 files
Functions: read, search, programming
Recognition of more than 2000 files and
200 folders.
Equalisation: Classic / Pop / Jazz / Rock
with the LOUD function
Technical characteristics:
Signal-to-noise ratio: Less than 70 dB
Frequency response: 20 Hz - 20 kHz
THD: Less than 0.1%
Maximum consumption: 500 mA



AMPLIFIERS



ZONEAMP4120

8 channels and 4 120W outputs at 100V
Amplified mixer

Code : H10513



4 Mic/Line inputs on XLR/6.35 Jack (TRS)
4 stereo inputs on RCA or 6.35 Mono Jack
4 link out outputs per zone on Phoenix plug
4 120W at 100V outputs on Phoenix plug
Microphone priority on input 1
Phantom power on inputs 1 to 4
Gain and tone control (3 bands) on channels 1 to 4
Gain control on all inputs
Tone control (2 bands) per zone
5 RJ45 connectors to connect 1x WP-1 per zone and to connect 1 x MIC-DESK4
General Mute key
Zone allocation 1 to 4 on each input
Signal / Peak display on each input
5 LED VU meters per zone
AFL / PFL front panel HP monitoring
Power supply: 230 V 50/60 Hz
Frequency response: 20 Hz - 20 kHz
Dimensions: 320 x 088 x 482 mm
19-inch rackable, Height: 2 units
Weight: 9 kg



WP-1

Wall-mounted controller for ZONEAMP4120 or PREZONE44

Code : H10508



1 front panel XLR microphone input
1 front panel RCA line input
1 back panel RJ45 connection
Front panel volume control
ON/OFF Switch
Source display shown by LED
DC15V power by RJ45 cable from the ZONEAMP4120 or the PREZONE444
Dimensions: 80 x 80 x 50 mm
Weight: 0.2kg



MIC-DESK4

Microphone base for ZONEAMP4120 or PREZONE444

Code : H10509



1 front panel XLR microphone input
1 rear RJ45 output
Talk switch on front panel to enable microphone
Chime switch to launch chime
Zone selection switch
Volume setting (Microphone and Chime)
Lock/unlock switch to block zone selection
LED level display
Power by RJ45 cable from the ZONEAMP4120 or the PREZONE444
Frequency response: 45 Hz - 15 kHz
T.H.D (1 kHz nominal power): < 0.1%
Dimensions: 140 x 60 x 205 mm
Weight: 0.9kg



RJMF10

RJ45 M/F cable 10cm

Code : H10929



8 INPUTS

Each input can be routed to your chosen zone or zones.
Installer settings are accessible with a screwdriver.

4 OUTPUTS

The ZONEAMP4120 is equipped with a monitoring loudspeaker to verify the signal sent to each output.

Send your source to the zone of your choice
 Envoyez la source sur la zone de votre choix

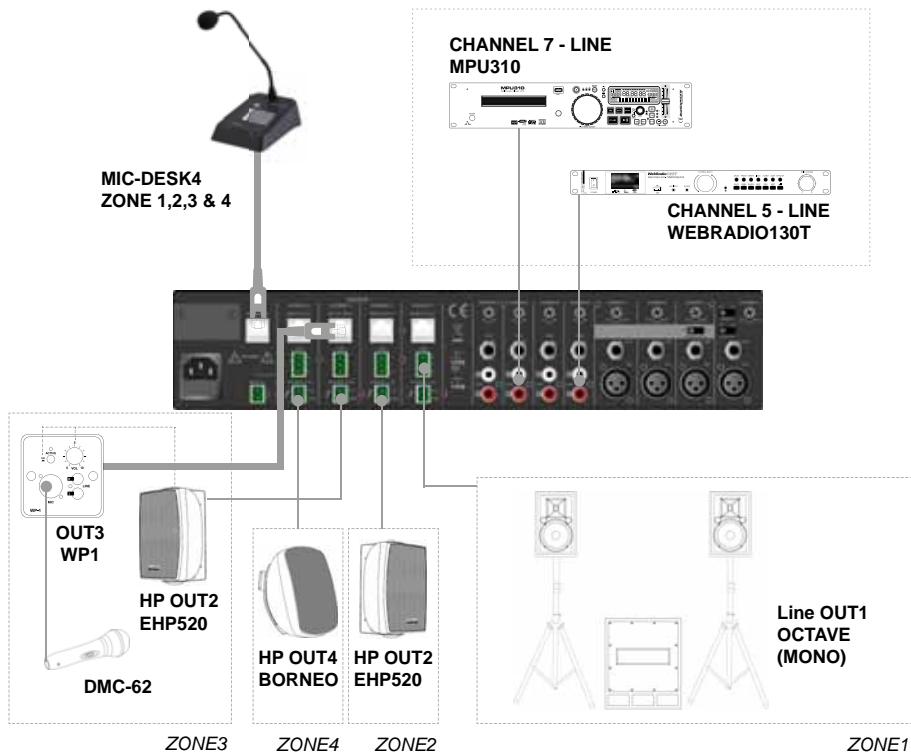

Example of usage of the
 ZONEAMP4120



NEW

MX82
 1U 8IN 2OUT stereo mixer with priority + Remote Mic

Code : H10926



Rated output Level/impedance : 0 dB / 600 Ohms balanced
 Input sensitivity / Impedance:
 Mic input (CH1-2) - 60 dB- - 16dB / 20 Ohms balanced
 Line input (CH1-6) - 60 dB- + 4dB / 20 Ohms balanced
 Frequency Response [-1 dB]: 20 Hz - 20 000 Hz
 T.H.D: < 0,1%
 Crosstalk: → 70 dB
 Equalization :
 Mic input : High: 12 kHz ± 15 dB / Mid : 2,5 kHz ± 15 dB / Low : 80 Hz ± 15 dB
 Output:
 High: 10 kHz ± 15 dB / Low : 100 Hz ± 15 dB
 Hum & Noise: →90 dB
 Power source: AC 240 V
 Weight: 9 kg
 Dimensions: 482 x 44 x 320 mm



8 INPUTS

Each input can be routed to your chosen zone or zones. Installer settings are accessible with a screwdriver.



2 OUTPUTS

The MX82 has 2 outputs equipped with a 2-band equalizer and independent level adjustment.

MULTI SOURCE PLAYERS



PREZONE88

Analog matrix 8 inputs 8 outputs 8 outputs

Code : H10927



- 8 Music input and 8 outputs with full matrix
- 4 remote microphone stations with link in and out for extension
- A Paging microphone input with phantom
- DRP(Digital recording and playback) up to 60secs
- Output extension for using multiple MTX88 up to 4 units
- 8 contact clause for playing message automatically
- Priority: PAGING → DRP → MRM → MWP8A → BGM
- 8 BGM input indicators [-20dB]
- Easy installation with CAT-5 cable
- Balanced output and tone controls (100Hz/10kHz)



MIC-DESK16M

16-zone micro console for matrix

Code : H10978



MIC-DESK8M

8-zone micro console for matrix

Code : H10977



WP8

Wall controller + source selector + MIC line IN for matrix

Code : H10928



WS8

Wall controller + source selector for matrix

Code : H10979



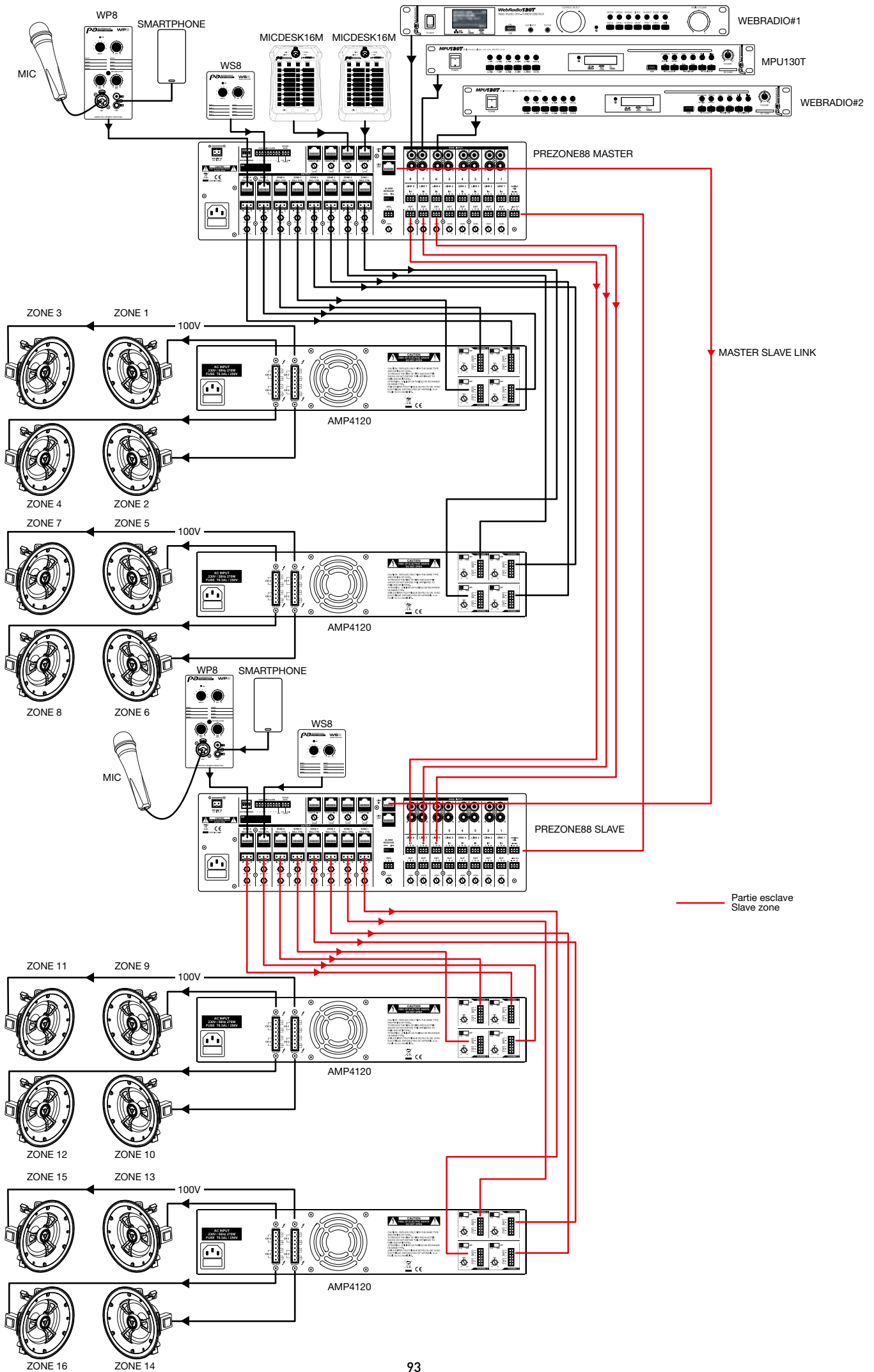

MULTI SOURCE PLAYERS



PREZONE444

8 channels and 4 independent output zones mixer

Code : H10507



★★★★★



★★★★★

4 Mic/Line inputs on XLR/6.35 Jack (TRS)
 4 stereo inputs on RCA or 6.35 Mono Jack
 4 line outputs per zone on Phoenix plug
 Microphone priority on input 1
 Phantom power on inputs 1 to 4
 Gain and tone (3 bands) on input 1 to 4
 Gain control on all inputs
 Tone control (2 bands) per zone
 5 RJ45 connectors to connect 1x WP-1 per zone and to connect 1x MIC-DESK4
 General Mute key
 Zone allocation 1 to 4, on each input
 Signal / Peak display on each input
 5 LED VU meters per zone
 AFL / PFL front panel HP monitoring
 Power supply: 230 V 50/60 Hz DC 24V
 Dimensions: 320 x 088 x 482 mm
 19-inch rackable, Height: 2 units Weight: 5 kg

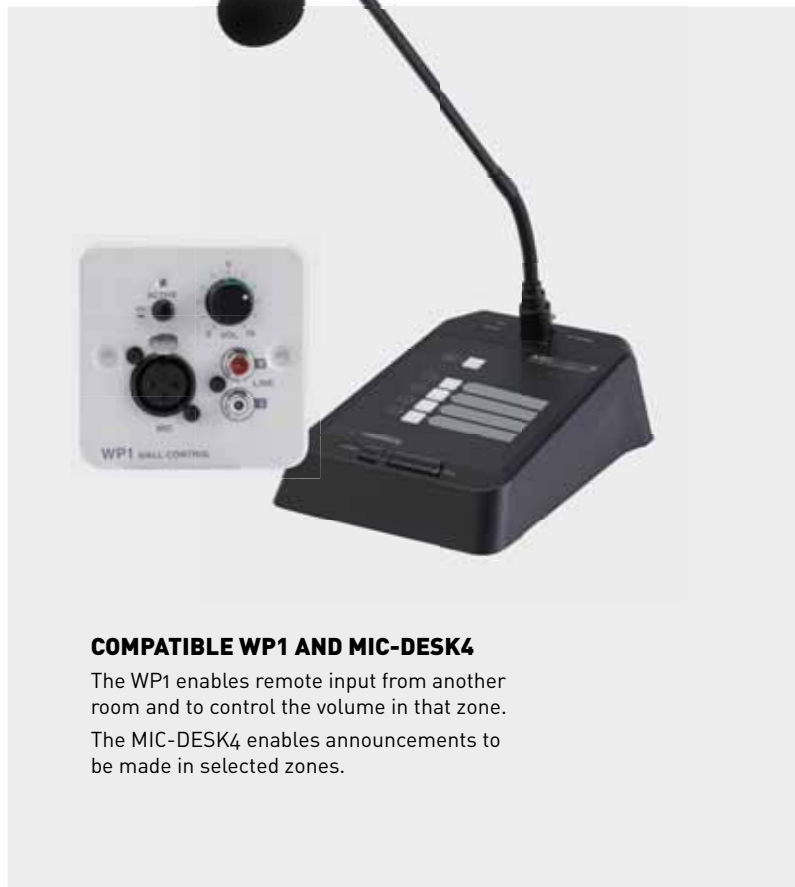

COMPATIBLE WP1 AND MIC-DESK4

The WP1 enables remote input from another room and to control the volume in that zone.
 The MIC-DESK4 enables announcements to be made in selected zones.

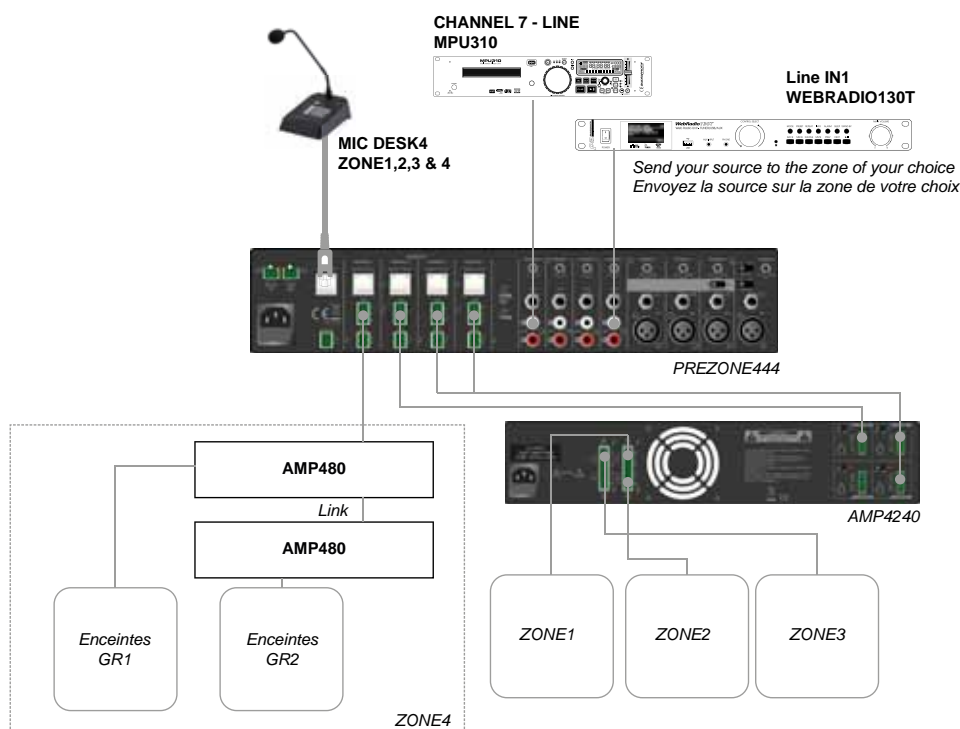



PREZONE642

Mixer 10 inputs/Preamp 2 zones 6 microphone inputs - 4 line inputs - 2 zones

Code : H9902



★★★★★



★★★★★

6 Mic/Line inputs on XLR/6.35 Jack
 CH1 and 2 phantom power and priority microphone
 4 stereo inputs on RCA or Jack
 Zones 1 and 2 balanced outputs on XLR
 Balanced SUB output per zone on Jack
 Stereo REC Output output on RCA
 Gain and tone (3 bands) on inputs 1 to 4
 Gain setting on stereo inputs
 Tone control (2 bands) per zone
 SUB volume per zone setting
 Zone allocation and PFL per input
 LED signal and Peak display
 8 LED VU meters per zone
 Headphone output with volume (zones and PFL)
 Power supply: 230 V 50/60 Hz DC24V
 Dimensions: 295 x 085 x 482 mm
 19-inch rackable, Height: 2 units
 Weight: 5 kg



MICROPHONE AND LINE INPUT

EACH MICROPHONE INPUT HAS:

- Gain setting
- 3-band equalizer
- These settings are reserved for installation and can only be modified by means of a screwdriver

EACH LINE INPUT HAS:

- Gain setting. (This setting is reserved for installation and can only be modified by means of a screwdriver)

AN ADVANCED MASTER SECTION

EACH ZONE HAS:

- Its own volume
- Its own equalisation
- Its own SUB output level setting
- Its own output level display

THE HEADPHONE SECTION IS ADVANCED WITH:

- Listening selection per channel via a PFL switch per increment
- The possibility to listen to each output independently via a zone selector.



PM4.2 MEDIAMIX

An all-in-one solution with FM RDS, USB reader and 2-zone balanced outputs.

Code : B00124



★★★★★



★★★★★

Internal USB reader compatible with MP3, WMA and WAV files.
 FM RDS radio with pre-set stations
 Infrared remote control
 Reading of 3 priority messages (manual and programmed reproduction)
 Audio mixer up to 4 sources:
 - USB reader/FM radio
 - 2 external line inputs
 - Microphone input with adjustable automatic talkover
 Recording output per RCA plug balanced outputs per zone
 Priority urgent message input.
 Muting of main channels. (contact closed = muting)
 Power supply: AC 100/240V - 50/60Hz
 Dimensions: 483 x 44 x 162 mm
 Net weight: 3.5 kg



MULTI SOURCE PLAYERS



USB3.1-RDS

CD / USB /Tuner reader

Code : B00364



The USB3.1-RDS reader combines different audio sources.
 AM/FM radio with RDS system and 18 pre-set stations
 MP3/WMA compatible audio CD reader
 USB/SD/SDHC reader up to 64 Go MP3/WMA sampling up to 48 kHz/320 kbit/s
 1 RCA Tuner output / 1 RCA CD output
 1 mixed RCA output
 RS-232 input for home automation systems
 Power supply: AC 100/240V - 50/60Hz
 DC 24 V back-up power supply
 Dimensions: 482 x 44 x 330 mm
 Net weight: 4 kg



- 1 RCA Tuner output / 1 RCA CD output
- 1 mixed RCA output
- AM/FM radio: with RDS system and 18 pre-set stations
- MP3/WMA CD reader
- USB/SD card media reader



★★★★★



★★★★★



★★★★★



★★★★★



MPU130BT

MP3 CD player + USB /SD + Tuner + BT

Code : H10961



AVM protected USB/Mp3 player
 USB reader with a USB mass storage output (at the front, max 16Go, FAT32 formatted)
 Bluetooth 2.1
 SD and SDHC reader with a front slot (16 Go max)
 Output volume control
 AM/FM Tuner with autoscans and a 10 stations memory capacity
 A button allows you to browse the repertoires and tracks
 Infrared remote control supplied
 Random or programmable playlist
 Unbalanced (-10 dB) RCA output
 Mountable in 19" wide racks and ON/OFF power switch at the front
 Dimensions : 482 x 44 x 275 mm (1x19" unit)
 Power supply : 230 V, AC - 50 Hz or 12 V, DC
 Weight : 3.4 kg



SOURCE CONTROL

The MPU130T is a true multimedia centre capable of supplying a continuous sound atmosphere no matter what the source is. It's very easy to use thanks to its single output, it can be controlled independently by remote control, or directly from the front panel. Its USB and SD ports give access to hundreds of hours of non-stop music that can be pre-programmed or read randomly.



★★★★★



★★★★★



★★★★★



★★★★★

NEW



WEBRADIO130App

WEBradio LAN LAN WIFI+FM DAB+USB Reader + App

Code : H10963



Radio: Ethernet / Wifi Internet radio, DAB and DAB+ digital radio, FM with RDS
 Mp3 reader: USB port for reading mp3/ AAC/WMA/FLAC files on USB flash drive or FAT32 external disk drive
 Shared files: Audio file sharing available on your computer network to pool your favourite playlists
 Programmable power on:
 Infrared remote control
 Aux input on 3.5mm Jack
 Line level outputs on RCA and Headphone on 3.5mm Jack
 Power supply: 230V - 50/60Hz or DC12V
 Dimensions: 483 x 44 x 265 mm
 Net weight: 2.9 kg



- Internet or DAB radio for an international selection of digital music
- USB port to play MP3 files on your hard drive
- Share audio files on your computer network
- Webradio control by mobile application



Webradio control by mobile application. Android and iOS compatible



HEARING LOOP SYSTEM

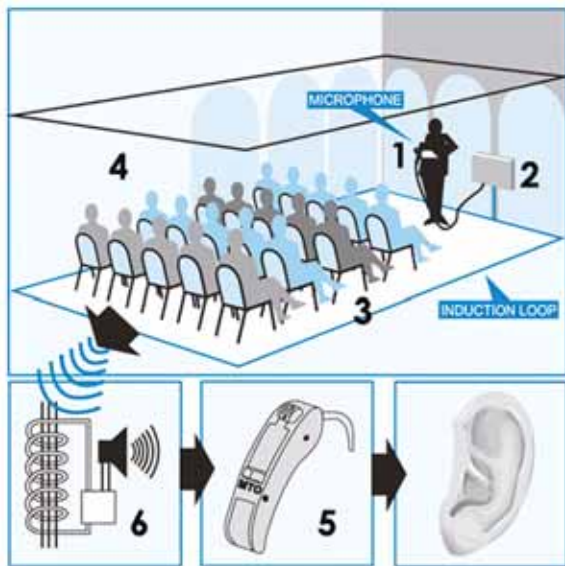

ABOUT THE HEARING LOOP SYSTEM

A hearing loop or induction loop is a hearing aid system for the hearing-impaired using a magnetic induction loop.

With this system, the sound from a speaker's microphone, PA equipment, TV set, etc. is transmitted wirelessly to the hearing aid of the person, who can hear it without being disturbed by any ambient noise. This system is mainly used in public places (conference rooms, cinemas, courts, churches, counters, etc.)

A large number of conventional hearing aids incorporate the "T" loop function.

Hearing loops are mainly installed in rooms.

The installation consists of an electrical wire that travels around the perimeter of the room thus forming a loop. This loop is connected to an audio amplifier. The hearing aid has a coil, often called "T" or "T-coil".

This coil, placed inside the hearing aid, is also made of a wire that makes a large number of turns.

MAGNETIC FIELD

The magnetic field generated by the large loop around the room will cross the small loops in the hearing aid and, by the principle of induction, the electrical signal present in the large loop will end up in the small ones.

This is how the signal from the audio amplifier is transmitted to the hearing aid, which will then return it to the ear of the hearing-impaired person.



REGULATIONS

The 2005 - 102 Act of 11 February 2005 sets out the requirement for public establishments to be accessible to people with disabilities before 1 January 2018

This obviously applies to establishments open to the public, such as:

Administrative and cultural facilities,

Health buildings,

Sports facilities,

But also supermarkets, cinemas, public transport, etc.

Facilities must comply with the standard: EN 60118-4:

Background noise (electromagnetic pollution) must be < 32 dB at 400 mA/m

The magnetic field must be between +/- 3 dB for a signal from 1 kHz to 400 mA/m

The frequency response must be 100 Hz - 5 kHz at +/- 3dB

NEW



BM-PORTABLE
Portable and autonomous loop amplifier

Code : H10799



This portable loop system makes it easy to equip a desk or counter. Made of ABS, it has an integrated microphone, amplifier, rechargeable battery and an induction loop for a coverage of: 1.2 m². Charger included.

NEW



BM-KIT
Loop amplifier kit for counter use

Code : H10795



Induction loop kit for equipping: counters, reception desks or service desks. This kit includes:
 1 x induction loop amplifier
 1 x surface microphone
 1 x loop
 1 x power supply
 3 x "Space adapted for the hearing-impaired" stickers.
 2 inputs: 1 microphone/line and 1 line
 Phantom power
 Compressor and noise limiter
 Output protection and control
 Power: 230 V 50/60 Hz - 12 V DC 1.5 A
 Size: 92 x 52 x 18 mm
 Weight: 0.850 kg

NEW



BM-A250
Loop amplifier for 250 m² area

Code : H10796



Class D amplifier for approximately 250 m²
 3 inputs: 2 line or microphone inputs (connector: 1 Phoenix and Combo), 1 priority 100 V input
 Monitoring and detection of power supply, amplifier and loop faults with NO-NC relay.
 Automatic gain control
 Correction control due to metal losses
 Power: 230 V 50/60 Hz
 Size: 483 x 43 x 215 mm
 Weight: 2.47 kg

NEW



BM-A1000
Loop amplifier for 1000 m² area

Code : H10797



Class D amplifier for approximately 1000 m²
 3 inputs: 2 line or microphone inputs (connector: 1 Phoenix and Combo), 1 priority 100 V input
 Monitoring and detection of power supply, amplifier and loop faults with NO-NC relay.
 Integrated phase shift module (output 90° or 0°)
 Automatic gain control
 Correction control due to metal losses
 Power: 230 V 50/60 Hz
 Size: 483 x 43 x 215 mm
 Weight: 2.47 kg

NEW



BM-TEST
Hearing aid simulator for loop amp test

Code : H10798



BM-TEST is a compact listening device for magnetic induction loop systems. It can be used in different situations:

- To determine if an induction loop is working properly
- For hearing-impaired people who do not wear a hearing aid
- For wearers of hearing aids that do not have a "T" function

The kit comprises:
 1 x loop receiver
 1 x headset
 2 x AAA batteries
 Frequency response: 20 Hz - 6 kHz
 Battery life: >100 hours

NEW



BM-SCAN
Magnetic field meter

Code : H10878



The BM-SCAN field strength meter has been designed to ensure that magnetic loop systems are installed and certified according to the new IEC 60118-4 standard. When these standards are met, the comfort of the user will be identical wherever he/she uses a hearing aid with the T position.

3.5 mm headphone jack socket
 Power supply: 9 V battery (not included)

NEW



BM-Cu50
Copper tape 50 m - 18 mm wide x 0.1 mm thick

Code : H10800



The BM-Cu50 is an 18-mm wide, 0.1-mm thick (1.8 mm² cross-section) copper tape insulated by a 0.05 mm Melinex band. Resistance +/- 10mΩ/m.
 Cables specially designed for induction loops where the loop must go under carpets or in places not suitable for conventional cables.

50 m coil

NEW



BM-Cu100
Copper tape 100 m - 18 mm wide x 0.1 mm thick

Code : H10801



The BM-Cu100 is a 18 mm wide, 0.1-mm thick (1.8 mm² cross-section) copper tape insulated by a 0.05 mm Melinex band. Resistance +/- 10mΩ/m.
 Cables specially designed for induction loops where the loop must go under carpets or in places not suitable for conventional cables.

100 m coil



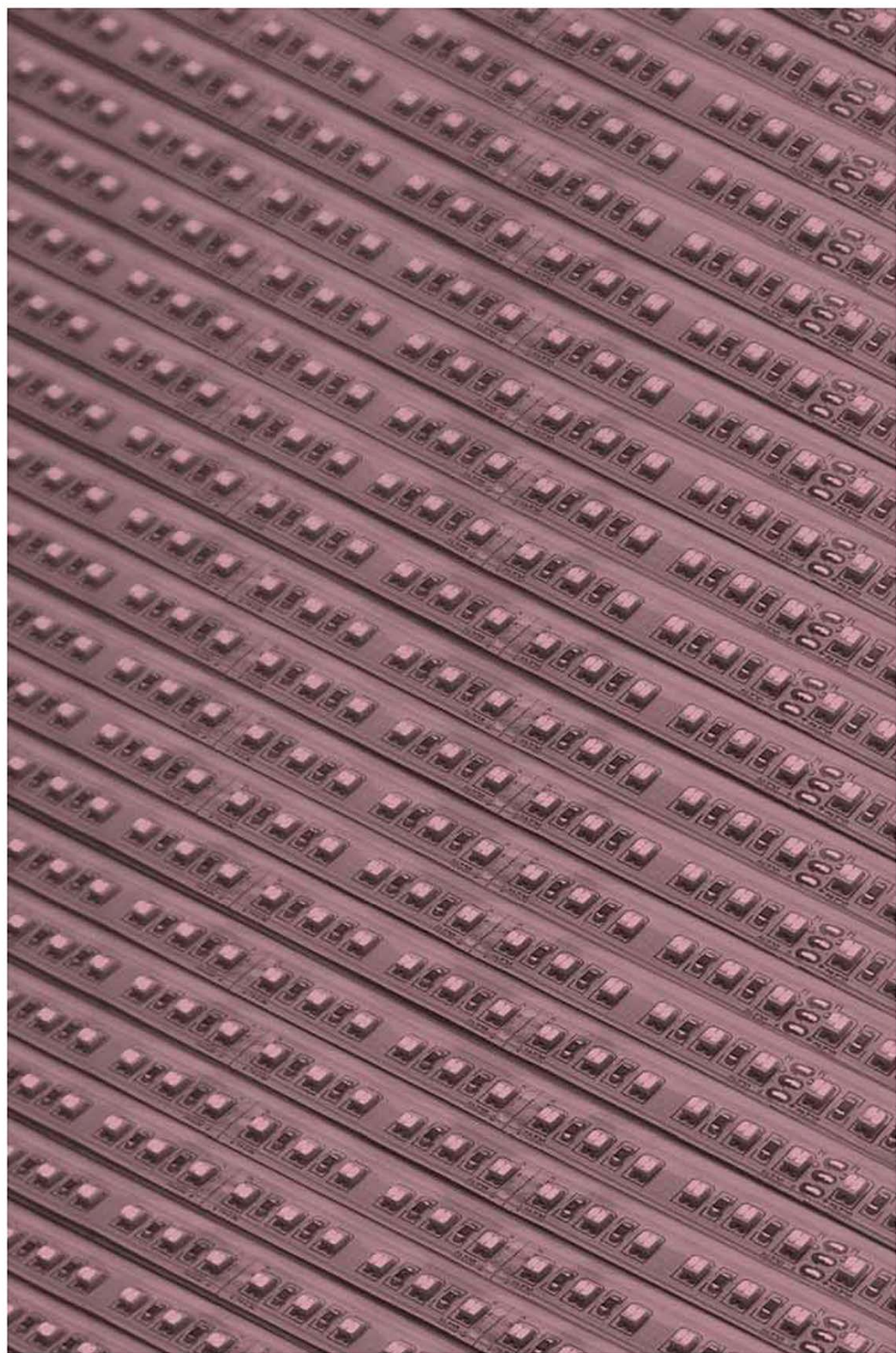

LIGHT INTEGRATION

LED RIBBONS
CONTROLLERS
DRIVERS
BOOSTERS AND MANAGERS
POWER SUPPLIES
PROFILES AND DIFFUSERS
ACCESSORIES
DECORATION PROJECTORS

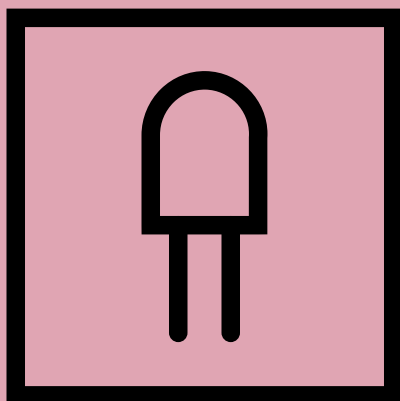

LED RIBBONS

Intense colours, bright white or softened light, our ribbons ensure an exceptional rendering in ambient lighting as well as enhancing your spaces.

IP67	60 LEDs/m	LED SMD 5050	Ra 80
------	-----------	--------------	-------

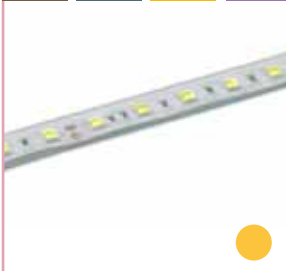

PURETAPE6067-WARM
3000°K White LED ribbon
Roll of 5 meters - IP67 - 60 LEDs/meter

Code : H9861



Monochrome adhesive ribbon of 300 warm white LEDs for 5m
Colour temperature: 3000°K
Luminosity: 1080 lumens/m
Power required: 14.4W/m (72W for 5m)
Voltage required: 24V (+ and -)
Cuttable every 10 cm (6LEDs)
IP67: Full silicone sheath

IP20	60 LEDs/m	LED SMD 5050	Ra 80
------	-----------	--------------	-------

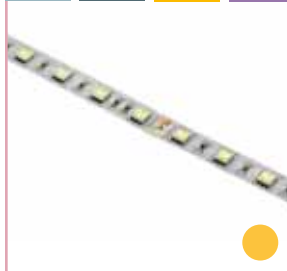

PURETAPE6020-WARM
3000°K White LED ribbon
Roll of 5 meters - IP20 - 60 LEDs/meter

Code : H10535



Monochrome adhesive ribbon of 300 warm white LEDs for 5m
Colour temperature: 3000°K
Luminosity: 915 lumens/m
Power required: 14.4W/m (72W for 5m)
Voltage required: 24V (+ and -)
Cuttable every 10 cm (6LEDs)
IP20: no protection no sealing

IP20	60 LEDs/m	LED SMD 5050	Ra 80
------	-----------	--------------	-------



LSI-60WW-5050-IP20-5M
Highly luminous flexible light strip (1320lm/m) containing 60 SMD-5050 white LEDs/meter.

Code : B05413



Monochrome adhesive ribbon of 300 warm white LEDs for 5m
Colour temperature: 3000°K
Luminosity: 1320 lumens/m
Power required: 14.4W/m (72W for 5m)
Voltage required: 24V (+ and -)
Cuttable every 10 cm (6LEDs)
IP20: no protection no sealing

IP20	120 LEDs/m	LED SMD 3528	Ra 80
------	------------	--------------	-------



LSI-120WW-3528-IP20-5M
JB SYSTEMS Highly luminous flexible light strip (960lm/m) containing 120 white LEDs/meter.

Code : B05410



Monochrome adhesive ribbon of 600 warm white LEDs for 20m
Colour temperature: 3000°K
Luminosity: 960 lumens/m
Power required: 9.6W/m (48W for 5m)
Voltage required: 24V (+ and -)
Cuttable every 10 cm (6LEDs)
IP20: no protection no sealing

IP65	120 LEDs/m	LED SMD 3528	Ra 80
------	------------	--------------	-------

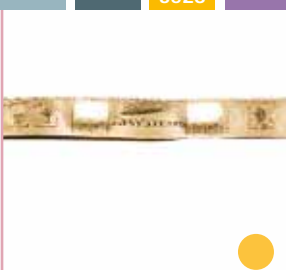

LSI-120WW-3528-IP65-5M
JB SYSTEMS Highly luminous flexible light strip (960lm/m) containing 120 white LEDs/meter.

Code : B05411



Monochrome adhesive ribbon of 600 warm white LEDs for 20m
Colour temperature: 3000°K
Luminosity: 960 lumens/m
Power required: 9.6W/m (48W for 5m)
Voltage required: 24V (+ and -)
Cuttable every 5 cm (6LEDs)
IP65: Upper molded silicone dome

IP20	144 LEDs/m	LED SMD 5630	Ra 80
------	------------	--------------	-------



PURETAPE14420-WARM
3000°K White LED ribbon
Roll of 5 meters - IP20 - 144 LEDs/meter

Code : H10536



Double monochrome adhesive ribbon of 720 warm white LEDs for 5m
Colour temperature: 3000°K
Luminosity: 2452 lumens/m
Power required: 47.5W/m (238W for 5m)
Voltage required: 24V (+ and -)
Cuttable every 8.4 cm (12 LEDs)
IP20: no protection no sealing

IP67	60 LEDs/m	LED SMD 5050	Ra 85
------	-----------	--------------	-------



PURETAPE6067-COLD
6000°K White LED ribbon
Roll of 5 meters - IP67 - 60 LEDs/meter

Code : H9862



Monochrome adhesive ribbon of 300
Colour temperature: 6000°K
Luminosity: 1170 lumens/m
Power required: 14.4W/m (72W for 5m)
Voltage required: 24V (+ and -)
Cuttable every 10 cm (6LEDs)
IP67: Full silicone sheath

IP20	60 LEDs/m	LED SMD 5050	Ra 85
------	--------------	--------------------	----------



PURETAPE6020-COLD
6000°K White LED ribbon
Roll of 5 meters - IP20 - 60 LEDs/meter

Code : H10537



Monochrome adhesive ribbon of 300 cold white LEDs for 5m
Colour temperature: 6000°K
Luminosity: 1190 lumens/m
Power required: 14.4W/m (72W for 5m)
Voltage required: 24V (+ and -)
Cuttable every 10 cm (6LEDs)
IP20: no protection no sealing

IP20	120 LEDs/m	LED SMD 3527	Ra 80-85
------	---------------	--------------------	-------------



PURETAPE12020-WARMCOLD
3000+6000°K White LED ribbon
Roll of 5 meters - IP20 - 120 LEDs/meter

Code : H10539



Two-tone adhesive ribbon of 600 warm and cold white LEDs for 5m
Colour temperature: 3500K/6500K
Luminosity: 1264 lumens/m
Power required: 19.2 W/m (96W for 5m)
Voltage required: 24V (+ and -)
Cuttable every 5.3cm (6 LEDs)
IP20: no protection no sealing

IP67	120 LEDs/m	LED SMD 3527	Ra 80-85
------	---------------	--------------------	-------------



PURETAPE12067-WARMCOLD
3000+6000°K White LED ribbon
Roll of 5 meters - IP67 - 120 LEDs/meter

Code : H10540



Two-tone adhesive ribbon of 600 warm and cold white LEDs for 5m
Colour temperature: 3500K/6500K
Luminosity: 1264 lumens/m
Power required: 19.2 W/m (96W for 5m)
Voltage required: 24V (+ and -)
Cuttable every 5.3cm (6 LEDs)
IP67: Full silicone sheath

IP20	144 LEDs/m	LED SMD 5630	Ra 85
------	---------------	--------------------	----------



PURETAPE14420-COLD
6000°K White LED ribbon
Roll of 5 meters - IP20 - 144 LEDs/meter

Code : H10538



Double monochrome adhesive ribbon of 720 cold white LEDs for 5m
Colour temperature: 6000°K
Luminosity: 3065 lumens/m
Power required: 47.5W/m (238W for 5m)
Voltage required: 24V (+ and -)
Cuttable every 8.4 cm (12 LEDs)
IP20: no protection no sealing

POSSIBLE CONFIGURATIONS

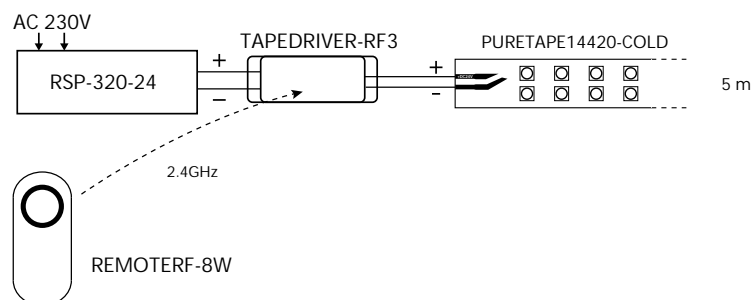
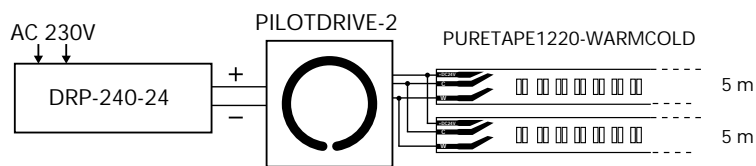

LED RIBBONS

Intense colours, bright white or softened light, our ribbons ensure an exceptional rendering in ambient lighting as well as enhancing your spaces.

IP67

60
LEDs/m

LED
SMD
5050





COLORTAPE6067
3-colour LED ribbon
Roll of 5 meters - IP67 - 60 LEDs/meter

Code : H9860



Trichromatic adhesive ribbon of 300 RGB LEDs for 5m
Luminosity: 510 lumens/m
Power required: 14.4W/m [72W for 5m]
Voltage required: 24V (+ and -)
Cuttable every 10 cm [6LEDs]
IP67: Full silicone sheath

IP65

60
LEDs/m

LED
SMD
5050





COLORTAPE6065
3-colour LED ribbon
Roll of 5 meters - IP65 - 60 LEDs/meter

Code : H9994



Trichromatic adhesive ribbon of 300 RGB LEDs for 5m
Luminosity: 510 lumens/m
Power required: 14.4W/m [72W for 5m]
Voltage required: 24V (+ and -)
Cuttable every 10 cm [6LEDs]
IP65: Upper molded silicone dome

IP65

60
LEDs/m

LED
SMD
5050





LSI-60RGB-5050-IP65-5M
JB SYSTEMS Flexible "colour changing"
LED strip containing 60 RGB LEDs/meter.

Code : B05418



Trichromatic adhesive ribbon of 300 RGB LEDs for 5m
Luminosity: 540 lumens/m
Power required: 14.4W/m [72W for 5m]
Voltage required: 24V (+ and -)
Cuttable every 10 cm [6LEDs]
IP65: Upper molded silicone dome

IP20

60
LEDs/m

LED
SMD
5050





COLORTAPE6020
3-colour LED ribbon
Roll of 5 meters - IP20 - 60 LEDs/meter

Code : H10541



Trichromatic adhesive ribbon of 300 RGB LEDs for 5m
Luminosity: 560 lumens/m
Power required: 14.4W/m [72W for 5m]
Voltage required: 24V (+ and -)
Cuttable every 10 cm [6LEDs]
IP20: no protection no sealing

IP20

60
LEDs/m

LED
SMD
5050





LSI-60RGB-5050-IP20-5M
Flexible "colour changing" LED strip
containing 60 RGB LEDs/meter.

Code : B05417





Trichromatic adhesive ribbon of 300 RGB LEDs for 5m
Luminosity: 540 lumens/m
Power required: 14.4W/m [72W for 5m]
Voltage required: 24V (+ and -)
Cuttable every 10 cm [6LEDs]
IP20: no protection no sealing

IP20

60
LEDs/m

LED
SMD
5050





LSI-60RGB-5050-IP20-20M
Flexible "colour changing" LED strip
containing 60 RGB LEDs/meter.

Code : B05419



Long 3-colour adhesive ribbon of 1200 RGB LEDs for 20m
Luminosity: 540 lumens/m
Power required: 14.4W/m [288W for 20m]
Voltage required: 24V (+ and -)
Cuttable every 10 cm [6LEDs]
IP20: no protection no sealing

IP65

30
LEDs/m

LED
SMD
5050





COLORTAPE3065
3-colour LED ribbon
Roll of 5 meters - IP65 - 30 LEDs/meter

Code : H9859



Trichromatic adhesive ribbon of 150 RGB LEDs for 5m
Luminosity: 255 lumens/m
Power required: 7.2W/m [36W pour 5m]
Voltage required: 24V (+ and -)
Cuttable every 10 cm [3LEDs]
IP65: Upper molded silicone dome

IP65

30
LEDs/m

LED
SMD
5050





LSI-30RGB-5050-IP65-5M
Flexible "colour changing" LED strip
containing 30 RGB LEDs/meter.

Code : B05416



Trichromatic adhesive ribbon of 150 RGB LEDs for 5m
Luminosity: 270 lumens/m
Power required: 7.2W/m [36W pour 5m]
Voltage required: 24V (+ and -)
Cuttable every 16.7 cm
IP65: Upper molded silicone dome

IP20	30 LEDs/m	LED SMD 5050
------	-----------	--------------



LSI-30RGB-5050-IP20-5M
Flexible "colour changing" LED strip containing 30 RGB LEDs/meter.

Code : B05415



Long 3-colour adhesive ribbon of 600 RGB LEDs for 20m
Luminosity: 270 lumens/m
Power required: 7.2W/m (36W pour 5m)
Voltage required: 24V (+ and -)
Cuttable every 16.7 cm
IP20: no protection no sealing

IP65	30 LEDs/m	LED SMD 5050
------	-----------	--------------



FL30-RGB SET-5050-3M
RGB flexible LED strip set, Length = 3m, incl IR-remote

Code : B05352



3-colour adhesive bars with 6x30 RGB LED strips for 3m in total
Voltage required: 24V (+ and -)
IP65: Upper molded silicone dome
Complete set supplied with power supply, controller, remote control and 6 strips of 50cm.

IP20	60 LEDs/m	LED SMD 5054	Ra 80-85
------	-----------	--------------	----------



COLORTAPE6020-WARM
LED ribbon 4-colour
Roll of 5 meters - IP20 - 60 LEDs/meter

Code : H10542



Ribbon of 300 4-colour RGBW LEDs for 5m
Luminosity: 879 lumens/m
Power required: 19.2W/m (96W for 5m)
Voltage required: 24V (+ and -)
Cuttable every 10 cm (6 LEDs)
IP20: no protection no sealing

IP67	60 LEDs/m	LED SMD 5054	Ra 80-85
------	-----------	--------------	----------



COLORTAPE6067-WARM
4-colour LED ribbon
Roll of 5 meters - IP67 - 60 LEDs/meter

Code : H10543



Ribbon of 300 4-colour RGBW LEDs for 5m
Luminosity: 646 lumens/m
Power required: 19.2W/m (96W for 5m)
Voltage required: 24V (+ and -)
Cuttable every 10 cm (6 LEDs)
IP67: Full silicone sheath

IP67	30 LEDs/m	LED SMD 5050
------	-----------	--------------



FLEXILED BLUE / 5M
Flexible led strip blue, L=5m, 24V

Code : B05347



Blue adhesive ribbon with 300 LEDs for 5m
Power required: 7.2W/m (36W pour 5m)
Voltage required: 24V (+ and -)
Cuttable every 16.5 cm
IP65: Upper molded silicone dome

NEW	IP20	60 LEDs/m	LED SMD 5050
-----	------	-----------	--------------



UVRIBBON6020
UV ribbon - 395nm
Roll of 5 meters - IP20 - 60 LEDs/meter

Code : H10771



UltraViolet adhesive ribbon with 300 LEDs for 5m
Power required: 14.4W/m (72W for 5m)
Voltage required: 24V (+ and -)
Cuttable every 10cm (6 leds)
IP20: no protection no sealing

NEW	IP67	60 LEDs/m	LED SMD 5050
-----	------	-----------	--------------



UVTAPE6067
UV ribbon - 395nm
Roll of 5 meters - IP67 - 60 LEDs/meter

Code : H10772



UltraViolet adhesive ribbon with 300 LEDs for 5m
Power required: 14.4W/m (72W for 5m)
Voltage required: 24V (+ and -)
Cuttable every 10cm (6 leds)
IP67: Full silicone sheath



ADVANTAGES of the LEDs?

- Long life, low maintenance
- Low energy cost
- Resistant to shocks and vibrations
- Very compact format
- No infrared and UV emissions

Ra
80

RA OR CRI

An Ra equal to 100 corresponds to natural daylight. At this level, the colours are perceived without any change (or loss) for the human eye.

LEDs which diffuse artificial light cannot claim an CRI greater than 90. In places that require that colours are complied with (e.g. points of sale or exhibitions), it is essential to provide equipment with an index greater than 70).

COLOUR TEMPERATURE

The unit of colour temperature is Kelvin degree (K°).

The lower the degree of temperature, the warmer the light. The higher the degree of temperature, the colder the light.



WHAT TYPE OF LED?



—
5054: 4 chips (RGBW)
of 0.32w/led
Good brightness

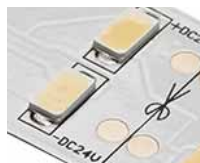

—
5630: 1 chip of 0.33w/led
Very high brightness
Only monochrome



—
5050: 3 chips (RGB) of
0.24w/led
Good brightness



—
5050: 1 hot white or cold
white chip of 0.24w/led
High brightness

Ideal for ambient lighting



—
3527: 2 chips (warm white
cold white) of 0.16w/led



—
WS2812B:
3 RGB chips of 0.24w/led with integrated control circuit
Each LED can be controlled independently



FLEX LED PIXEL

The ribbons of the SMARTTAPE range are equipped with the latest WS2812B LED technology. In SMD5050 (5x5mm) format, the integrated control circuit is directly embedded in the component. More discreet, these LEDs make it possible to have ribbons of only 10mm width with a pitch of only 16mm for the SMARTTAPE6020 model.

The installation is very simple, as only 3 cables are needed for operation ("+", "-", Data in).

Associated with a power supply and a SMARTCTL controller, you will get 300 kinds of patterns with the ability to control the speed and brightness.

IP20	30 LEDs/m	LED WS2812B	PIXEL
------	-----------	-------------	-------

SMARTTAPE3020
3-colour pixel LED strip of 30 LEDs/meter - IP20 - 5V

Code : H10596



3-colour adhesive ribbon of 150 RGB LEDs for 5m pixel version
Power required: 7.2W/m (36W pour 5m)
Voltage required: 5V DC
Cuttable every 3.3cm (1 LED)
IP20: no protection no sealing



IP20	60 LEDs/m	LED WS2812B	PIXEL
------	-----------	-------------	-------

SMARTTAPE6020
3-colour pixel LED strip of 60 LEDs/meter - IP20 - 5V

Code : H10597



3-colour adhesive ribbon of 300 RGB LEDs for 5m pixel version
Power required: 14.4W/m (72W for 5m)
Voltage required: 5V DC
Cuttable every 1.6 cm (1 LED)
IP20: no protection no sealing

NEW



IP65	60 LEDs/m	LED WS2812B	PIXEL
------	-----------	-------------	-------

SMARTTAPE6065
5m - IP65 - 60 LEDs/m-5V

Code : H10972



Voltage: 5 V DC
Power/m: 14,4 W
Length of each ribbon: 5 m
Sectile parts: 1,6 cm (1 LED)

NEW



IP67	60 LEDs/m	LED WS2812B	PIXEL
------	-----------	-------------	-------

SMARTTAPE6067
TRI pixel ribbon - 5m - IP67 - 60 LEDs/m-5V

Code : H10973



Voltage: 5 V DC
Power/m: 14,4 W
Length of each ribbon: 5 m
Sectile parts: 1,6 cm (1 LED)



SMARTCTL
HF remote control for SMARTTAPE ribbons of 2048 pixel max. - VDC

Code : H10598



Power supply: 5V DC
Max controlled number of pixels: 2048
Remote control : 433.92 MHz
Remote control range: 30m

100 W
5 V



LRS-100-5
5V DC 100W max. power supply IP20 1 output

Code : H10600



Power supply: 5V DC 100W max.
Output voltage : 5V DC - 20A
Power rating: 100 W
Supply voltage : 100 - 240V AC

50 W
5 V



LRS-50-5
5V DC 50W max. power supply IP20 1 output

Code : H10599



Power supply: 5V DC 50W max.
Output voltage : 5 V DC - 10 A
Power rating: 50 W
Supply voltage : 100 - 240V AC

NEW **M**



LRS-200-5
Alimentation 5v DC MeanWell série LRS,200W,IP20

Code : H10971



Power supply: 5V DC 200W max.
Output voltage : 5 V DC - 20 A
Power rating: 200 W
Supply voltage : 100 - 240V AC



TOUCH CONTROLLERS

Light at your fingertips.

Discover our new range of fully tactile and recessed LED light controllers. Fluid and highly accurate, choose the intensity and colour of your flex LED light with the tip of your finger.

288 W
24 V



PILOTdrive-1
Monochrome ribbon controller
3 x 4A - 12-24V - 12A max.

Code : H10560



Function:
- Dimmer 5% to 100% monochrome
- Direct access to a recorded scene
- «30S» Extinction of the ribbon after 30 seconds
Power supply: 12 - 24V DC
Intensity (Max load in amperes) :
4A x 3 (outputs) = 12A max
Dimensions: 86 x 86 x 36 mm
Weight: 208 g
Compatible with PILOTdrive and PILOTctl

192W
24 V



PILOTdrive-2
Controller for warm and cold white ribbons
2 x 4A - 12 - 24V - 8A max.

Code : H10561



Function:
- Dimmer 5% to 100% warm/cold white
- Direct access to a recorded scene
- "Mode" to switch between hot and cold
Power supply: 12 - 24V DC
Intensity (Max load in amperes) :
4A x 2 (outputs) = 8A max
Dimensions: 86 x 86 x 36 mm
Weight: 208 g
Compatible with PILOTdrive and PILOTctl

288 W
24 V



PILOTdrive-3
RGB ribbon controller
3 x 4A - 12-24V - 12A max.

Code : H10562



Function:
- Dimmer 5 % to 100 % RGB
- Direct access to a recorded scene
- 11 modes (fixed + step + fade colours)
Power supply: 12 - 24V DC
Intensity (Max load in amperes) :
4A x 3 (outputs) = 12A max
Dimensions: 86 x 86 x 36 mm
Weight: 208 g
Compatible with PILOTdrive and PILOTctl

384 W
24 V



PILOTdrive-4
RGBW ribbon controller
4 x 4A - 12-24V - 16A max.

Code : H10563



Function:
- Dimmer 5% to 100% RGBW
- Direct access to a recorded scene
- 12 modes- Direct access to white (fixed + step + fade colours)
Power supply: 12 - 24V DC
Intensity (Max load in amperes) :
4A x 4 (outputs) = 16A max
Dimensions: 86 x 86 x 36 mm
Weight: 208 g
Compatible with PILOTdrive and PILOTctl

2,4 GHz **DMX**
1 CH



PILOTctl-1
DMX controller + 2,4 GHz -1 zone - 1 colour

Code : H10564



Function:
- Dimmer 5% to 100% monochrome
- Direct access to a recorded scene
- «30S» Extinction of the ribbon after 30 seconds
Power supply: 240V
Output signal: 2,4 Ghz & DMX512
Operating distance: 30m and 2,4 Ghz
Dimensions: 112 x 112 x 48 mm
Weight: 225 g
Compatible with PILOTdrive and PILOTctl

2,4 GHz **DMX**
2 CH



PILOTctl-2
DMX controller + 2,4 GHz -1 zone - 2 colours

Code : H10565



Function:
- Dimmer 5% to 100% warm/cold white
- Direct access to a recorded scene
"Mode" to switch between warm and cold white
Power supply: 240V
Output signal: 2,4 Ghz & DMX512
Operating distance: 30m and 2,4 Ghz
Dimensions: 112 x 112 x 48 mm
Weight: 225 g
Compatible with PILOTdrive and PILOTctl

2,4 GHz **DMX**
3 CH



PILOTctl-3
DMX controller + 2,4 GHz -1 zone - 3 colours

Code : H10566



Function:
- Dimmer 5 % to 100 % RGB
- Direct access to a recorded scene
- 11 modes (fixed + step + fade colours)
Power supply: 240V
Output signal: 2,4 Ghz & DMX512
Operating distance: 30m and 2,4 Ghz
Dimensions: 112 x 112 x 48 mm
Weight: 225 g
Compatible with PILOTdrive and PILOTctl

2,4 GHz **DMX**
4 CH



PILOTctl-4
DMX controller + 2,4 GHz -1 zone - 4 colours

Code : H10567



Function:
- Dimmer 5% to 100% RGBW
- Direct access to a recorded scene
- 12 modes (fixed + step + fade colours)
- Direct access to white on 4 zones
Power supply: 240V
Output signal: 2,4 Ghz & DMX512
Operating distance: 30m and 2,4 Ghz
Dimensions: 112 x 112 x 48 mm
Weight: 225 g
Compatible with PILOTdrive and PILOTctl

4 ZONES 2,4 GHz DMX 4x4 CH



PILOTctl-16
DMX Controller + 2,4 GHz
4 zones - 4 colours per zone

Code : H10568



Wi-Fi 2,4 GHz RGBW



TAPElive4
Wi-Fi transmitter receiver for driver
TAPEDRIVER-WIFI4 2.4 GHz remote control

Code : H10572



2,4 GHz 4 CH



TAPEDRIVER-WIFI4
2.4GHz wi-Fi Controller
4 channels - 5-24VDC - 4 x 5A max.

Code : H10580



Function

- Dimmer 5% to 100% RGBW
- Direct access to a recorded scene
- 12 modes (fixed colour + step + fade colours)
- Direct access to white

Power supply: 240V
Output signal: 2.4 Ghz & DMX512
Operating distance: 30m and 2.4 Ghz
Dimensions: 112 x 112 x 48 mm
Weight: 225 g
Compatible with PILOTdrive and PILOTctl

Mode of communication: 2.4GHz Wi-Fi, 802.11b/g/n protocol
Power supply: 12-24V DC
Operating distance: Approx. 100m
Intensity: 4A x 4 (outputs) = 16A max
Power rating: 192W / 384W (12V / 24V)
Dimensions: 128 x 73 x 45 mm
Weight: 382 g

Remote Control 2.4GHz included

Mode of communication: 2.4GHz Wi-Fi
Power supply: 5 - 24V DC
Operating distance: 30m with its remote control
Intensity: 5A x 4 (outputs) = 20A max
Power rating: 100W / 240W / 480W (5V / 12V / 24V)
Dimensions: 175 x 44 x 30 mm
Weight: 150 g



POSSIBLE CONFIGURATIONS

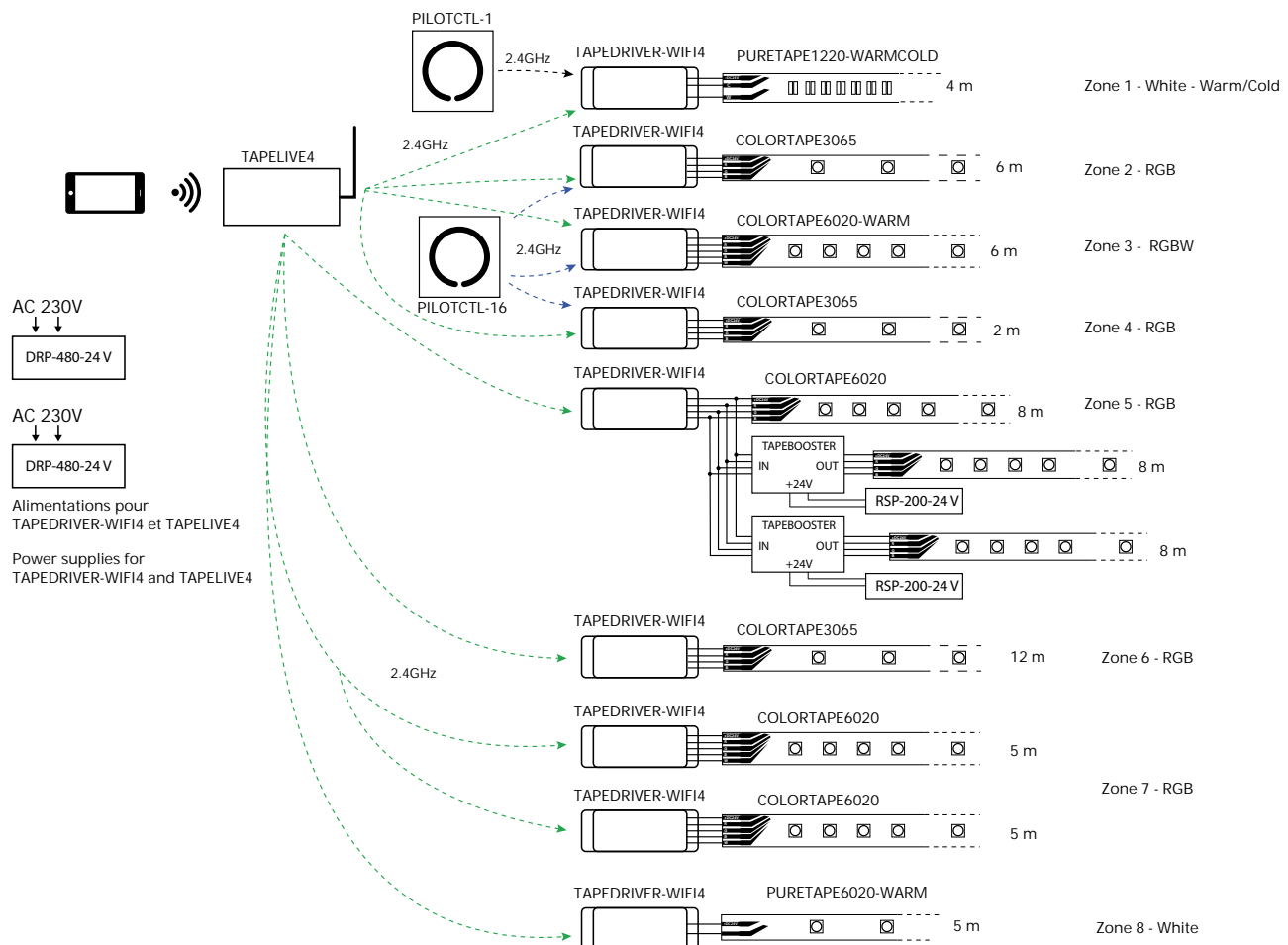

CONTROLLERS

NEW



SMART-CTL800

800 LED pixel ribbon controller - 8 SPI outputs

Code : H10949



SMARTAPE controller (LEDs WS2811, 2812 etc.)
 Inputs : DMX operation (16 channels) with dedicated software (simulator), stand alone mode
 Outputs: 8 Euroblock SPI outputs, max. 800 pixels to be distributed over the 8 outputs.
 Programming: RDM configuration and programming via Smart USB
 Power supply: 5 V DC Euroblock connectors
 DMX in/out: Euroblock connectors
 Dimensions: 130 x 100 x 100 x 30 cm
 Weight: 150 g

NEW



SMART-DMX

Box for pixel or DMX RGB ribbon control 2 universes

Code : H10968



Inputs : DMX (16 channels), simulator with specific software, stand alone mode
 Outputs: 2 DMX Euroblock outputs, 2x 512 DMX channels
 Programming: RDM configuration and programming via Smart USB
 Power supply: 5 V DC Euroblock connectors
 DMX in/out: Euroblock connectors
 Dimensions: 130 x 100 x 100 x 30 cm
 Weight: 150 g

NEW



SMART-USB

RDM interface for simul + pixel controller program

Code : H10948



USB/DMX interface for configuring the installation in RDM.

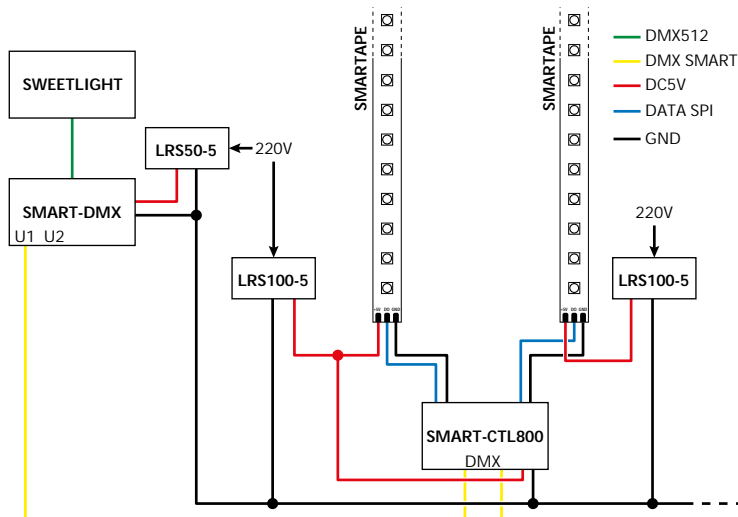
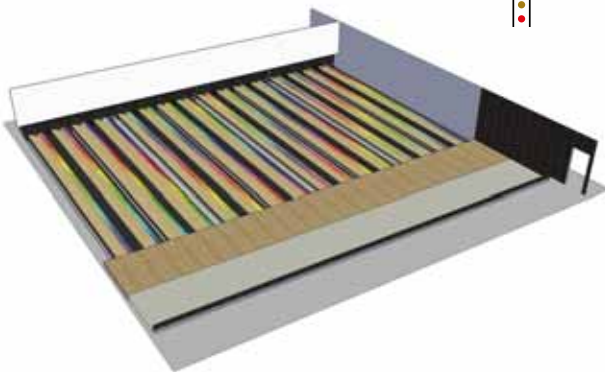
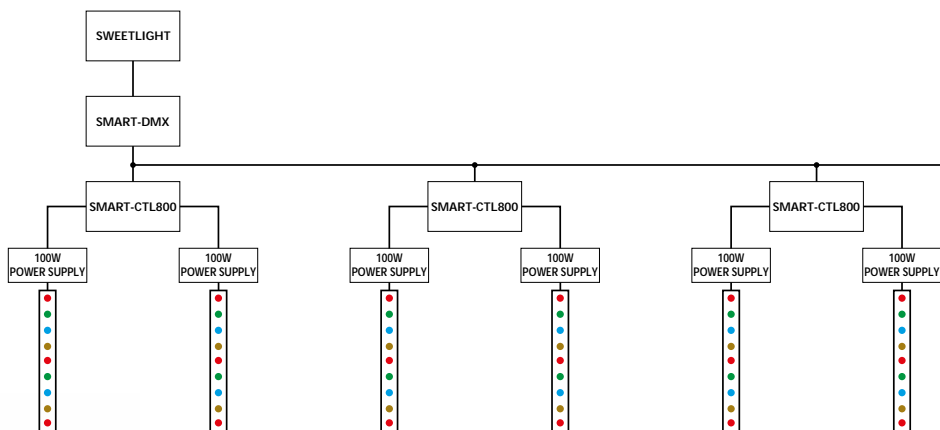

DRIVERS



2,4 GHz 3 CH

TAPEDRIVER-RF3
2.4GHz Controller
3 channels - 5-24VDC 3 x 6A max.

Code : H10577



Mode of communication: 2.4GHz
Power supply: 5 - 24V DC
Intensity (max charge in amperes) :
6A x 3 (outputs) = 18A max
Power rating: 90W / 216W / 432W
(5V / 12V / 24V)
Compatible remote control :
REMOTERF-8W & REMOTERF-10RGB
Operating distance: 30m
Dimensions: 175 x 44 x 30 mm
Weight: 150 g



2,4 GHz RGB

TAPEDRIVERTOUCH-RF3
Manual controller and 2.4GHz
3 channels - 12-24V DC - 3x 5A max.

Code : H10578



Mode of communication: 2.4GHz or manual
Power supply: 12 - 24V DC
Intensity (max charge in amperes) :
5A x 3 (outputs) = 15A max
Power rating: 180 W / 360 W (12 V / 24 V)
Compatible remote control :
REMOTERF-10RGB
Operating distance: 30m
Dimensions: 211 x 40 x 30
Weight: 180 g



2,4 GHz 4 CH

TAPEDRIVER-RF4
2.4GHz Controller
4 channels - 5-24VDC - 4 x 5A max.

Code : H10579



Mode of communication: 2.4GHz
Power supply: 5 - 24V DC
Intensity (max charge in amperes) :
5A x 4 (outputs) = 20A max
Power rating: 100 W / 240 W / 480 W
(5 V / 12 V / 24 V)
Compatible remote control :
REMOTERF-8RGBW
Operating distance: 30m
Dimensions: 175 x 44 x 30 mm
Weight: 150 g



8 zones
WHITE

REMOTERF-8W
2.4GHz remote controller
8 zones - 1 colour

Code : H10569



Mode of communication: 2.4GHz
Power supply: DC 5V (Lithium) - Mini
USB rechargeable battery
Number of controlled zones: 8 zones
Driver pilot: TAPEDRIVER-RF3
Operating distance: 30m



10 zones
RGB

REMOTERF-10RGB
2.4GHz remote controller
10 zones - 3 colours

Code : H10570



Mode of communication: 2.4GHz
Power supply: DC 5V (Lithium) - Mini
USB rechargeable battery
Number of controlled zones: 10 zones
- Direct access to a recorded scene
- 11 modes (fixed + step + fade colours)
Driver pilot: TAPEDRIVER-RF3 and
TAPEDRIVERTOUCH-RF3
Operating distance: 30m



NO WIRING BETWEEN THE DRIVERS



Our drivers are not wired together.
The information sent by the remote control automatically
synchronizes with the drivers thanks to the 2.4GHz Wi-Fi
technology.



DMX DRIVERS

Compatible with the COLOURTAPE and PURETAPE ranges, these modules convert your DMX or manual instructions into a power signal for your ribbons.

Assignable and equipped with a DMX input and output, they integrate perfectly into your installation. Combined with a suitable power supply, they can optionally control one monochrome ribbon, one RGB strip or three monochrome ribbons, one RGBW ribbon or four monochrome ribbons.



TAPEDRIVER-1

DMX controller for ribbons
1 channel - 12-24VDC - 6A max.

Code : H10573



For monochrome ribbon
DMX 1 channel
144W under 24V
Dimmer by dip-switches
Command in 0-10V control



TAPEDRIVER

DMX/Power converter
24V - 96 Watts max

Code : H9867



For monochrome and RGB ribbon
DMX 3 channels
96 W under 24 V
Dimmer by dip-switches



TAPEDRIVER-3

DMX controller for ribbons
3 channels - 12-24VDC - 3 x 2A max.

Code : H10574



For RGB ribbon
DMX 3 channels
144W under 24V
Choice of programs and colours by dip-switches



LED DMX-CONTROL SCREW MK2

360W/24V LED Ribbon Controller

Code : B05399



For monochrome and RGB ribbon
DMX 4 channels
60 W/ channel = 180 W under 12 VDC
120 W/ channel = 360 W under 24 VDC
Choice of programs and colours by dip-switches
WTR-DMX DONGLE compatible



LED DMX-CONTROL XLR Mk2

LED controller - DMX - 240W/24V

Code : B05401



For monochrome and RGB ribbon
DMX 4 channels
40 W/ channel = 120 W under 12 VDC
80 W/ channel = 240 W under 24 VDC
Choice of programs and colours by dip-switches and DMX



TAPEDRIVER-4

DMX controller for ribbons
4 channels - 12-24VDC - 4 x 2,5A max.

Code : H10575



For RGBW ribbon
DMX 4 channels
240 W under 24 V
Choice of programs and colours by dip-switches



TAPEDRIVER-12

DMX controller for ribbons
12 channels - 12-24VDC - 12 x 5A max.

Code : H10576



For all types of 24V ribbons
DMX 12 channels
1440 W under 24 V



DMX OPERATION

Example for a RGB ribbon
(3 channels)

Channel 1 : Red
Dimmer 0%-100%

Channel 2 : Green
Dimmer 0%-100%

Channel 3 : Blue
Dimmer 0%-100%



TAPEDIMMER
Dimmer for monochrome ribbon
24V - 432 Watts maximum

Code : H9866



Compatible with monochrome ribbons
Rotary potentiometer to adjust the output level
Power supply: 24 V DC
Maximum power: 432W in 24V -
Dimensions: 112 x 65 x 24 mm
Weight: 0.5 Kg



LED 1CH DIM WALL
12V / 24V Wall dimmer

Code : B05392



Compatible with monochrome ribbons
Rotary potentiometer to adjust the output level
IR remote control for M/A, standby, dimmer, 4 levels.
Power supply: 12 or 24V DC
Maximum power: 160W in 24V - 80W in 12V
Dimensions: 87 x 87 x 53 mm (box)
Weight: 0.150 Kg



TAPEBOOSTER-RGBW

Compatible with 4-colour, 3-colour and monochrome ribbons, this signal booster increases the number of ribbons connected on a serial controller.

Combined with a suitable power supply, it amplifies the received signal and allows you to connect more ribbons to the same controller for longer hose lengths without discontinuity or difference in brightness.

POSSIBLE CONFIGURATIONS

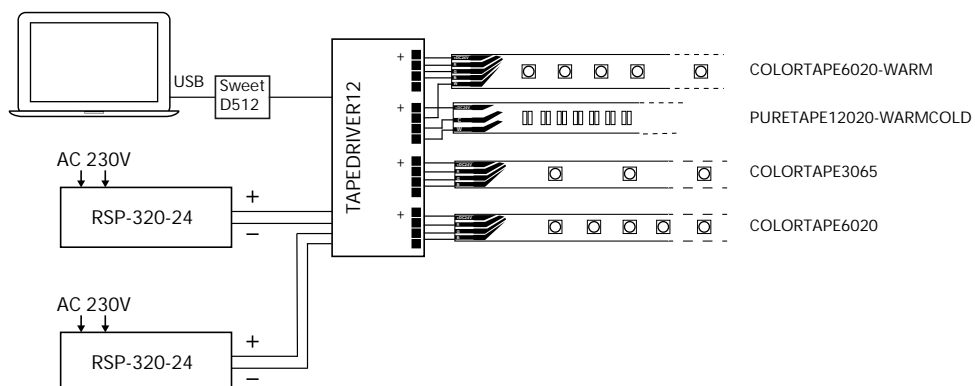

BOOSTERS AND MANAGERS



TAPEBOOSTER

RGB signal amplifier
24V - 576 Watts maximum

Code : H9865



Compatible with 3-colour and monochrome ribbons
Supply voltage: DC 24V
Maximum output load: 3x8A
Output signal: MLI constant voltage
Maximum output power: 576W(24V)
Dimensions: 107 x 65 x 24 mm
Weight: 0.5 kg



TAPEBOOSTER-1X10A

1 channel booster - 12-24V DC - 10A max

Code : H10769



Compatible with monochrome ribbons
Supply voltage: DC12V-24V
Maximum output load: 10A/CHx1
Output signal: MLI constant voltage
Maximum output power: 120W(12V) / 240W(24V)
Dimensions: 125 x 45 x H36 mm
Weight: 0.100 kg



TAPEBOOSTER-RGBW

4 channel booster - 5-24V DC
3 x 3A + 1 x 9A max.

Code : H10770



Compatible with 4-colour, 3-colour and monochrome ribbons
Supply voltage : DC5V-DC24 V
Maximum output load:
- RGB : 3Ax3CH
- W : 9Ax1CH
Output signal: MLI constant voltage
Maximum output power:
- RGB : 72Wx3CH
- W : 216W(24V)
Dimensions: 176 x 46 x 30 mm
Weight: 0.145 kg



LED REPEATER

LED-REPEATER RVB

Code : B05400



Compatible with 3-colour and monochrome ribbons
Supply voltage : DC12-24 V
Output signal: MLI constant voltage
Maximum output power:
- RGB : 80Wx3CH under 12V
- RGB : 160Wx3CH under 24V
Dimensions: 90 x 90 x 24 mm
Weight: 0.190 kg



POWTAPE

Control and power box
24V - 50W - Auto/DMX

Code : H9583



Compatible with 3-colour and monochrome ribbons
Integrated power supply: DC24 V
Maximum output power:
- RGB : 16Wx3CH total 50W
Integrated switch controller for:
Master/Slave, Colours, Musical, Programs.
4-channel DMX operation
CTLTAPE Wall Controller Connection.
Power supply: AC230V - 50 Hz
Dimensions: 332 x 70 x 40 mm
Weight: 1kg



CTLTAPE

Built-in DMX wall-mounted controller
4 channels - 2 program memories

Code : H9584



Compatible with 3-colour and monochrome ribbons:
Colour adjustment by potentiometer (with access to a fade program)
Adjustment of brightness/strobe by potentiometer
Setting the speed in Fade mode
2 adjustment memories
1 bouton Black Out (ON/OFF)
DMX 4 channels:
Red, Green, Blue, General/Strobe Dimmer
Power supply: DC12V - 1A (not provided)
Dimensions: 84 x 83 x 40 mm
Weight: 0.5 kg



POW121

Controller power supply
220V/12 V - 1A

Code : H9806



Power supply for CTLTAPE
Power supply: AC 240V - 50-60Hz
Output: 12V DC - 1A
Protection IP20



MINI LED MANAGER Mk3

LED DMX Power supply 100W 24V cv

Code : B04949



Compatible with 3-colour and monochrome ribbons
Integrated power supply: DC24 V
Maximum output power:
- RGB : 33Wx3CH total 100W
Integrated switch controller for:
Master/Slave, 16 Colours, Musical, programs.
4-channel DMX operation
Connection CTLTAPE between wall controller and ON / OFF switch
Power supply: AC230V - 50 Hz
Dimensions: 356 x 132 x 43 mm
Weight: 1.9 kg



**MICRO LED
MANAGER Mk2**

LED DMX Power supply 50W 24V cv

Code : B04950



Compatible with 3-colour and monochrome ribbons
 Integrated power supply: DC24 V
 Maximum output power:
 - RGB : 16Wx3CH total 50W
 Integrated switch controller for: Master/Slave, 16 Colours, Musical, programs.
 4-channel DMX operation
 Connection CTLTAPE between wall controller and ON / OFF switch
 Power supply: AC230V - 50 Hz
 Dimensions: 332 x 70 x 40 mm
 Weight: 0.950 kg



LED WALL DIMMER

Compact RGB remote control for LED projectors

Code : B04936



Compatible with 3-colour and monochrome ribbons:
 Colour adjustment by potentiometer (with access to a fade program)
 Adjustment of brightness/strobe by potentiometer
 Setting the speed in Fade mode
 2 adjustment memories
 1 bouton Black Out (ON/OFF)
 DMX 4 channels:
 Red, Green, Blue, General/Strobe Dimmer
 Power supply: DC12V - 1A (not provided)
 Dimensions: 84 x 83 x 40 mm
 Weight: 0.5 kg



LED RF-CONTROL DIM

1 channel single colour LED controller

Code : B05396



Compatible with monochrome ribbons
 Power: DC12-24 V
 Maximum output power:
 - 240 W under 12 V
 - 480 W under 24 V
 HF remote control (433.92 MHz) integrated for:
 M/A, stop 30s, dimmer, levels, night light
 RJ45 connection for Master/Slave synchronization
 Dimensions: 90 x 90 x 24 mm
 Weight: 0.250 kg



**LED RF-CONTROL
RGB**

3-channel RGB controller

Code : B05397



Compatible with tricolour ribbons
 Power: DC12-24 V
 Maximum output power:
 - 240 W under 12 V
 - 480 W under 24 V
 HF remote control (433.92 MHz) integrated for:
 M/A, stop 30s, dimmer, levels, night light
 RJ45 connection for Master/Slave synchronization
 Dimensions: 90 x 90 x 24 mm
 Weight: 0.250 kg



POSSIBLE CONFIGURATIONS

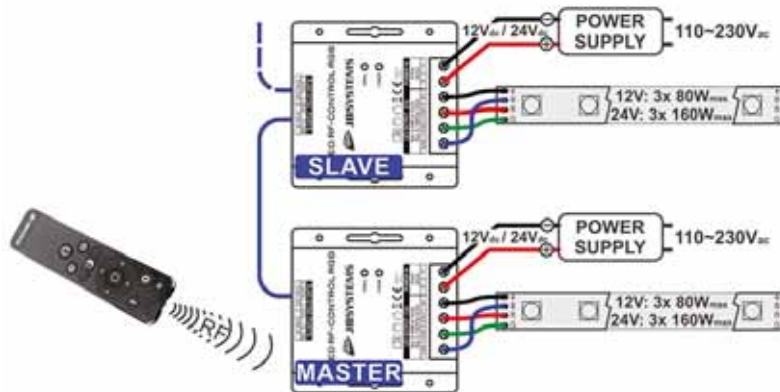

POWER SUPPLIES



A

POW2411P
Waterproof power supply for ribbon
24V DC - 30 Watts maximum

Code : H9881

Contest



B

EIP 060V0240LS
Switching power supply - 24Vdc/60W

Code : B05390

JBSYSTEMS



C

POW242
Power supply
24V - 50 Watts max - IP20

Code : H9807

Contest



D

POW244IP2
Power supply 24VDC 4.15A
100W max - IP65 - 2 outputs

Code : H10362

Contest



E

LRS-100-24
Power supply 24VDC
100W max. IP20 - 2 outputs

Code : H10581

Contest



F

DR120-24
Power supply MW
120W Stabilized, for DIN rail

Code : H9926

Contest



G

ESE 150-24S
Switching power supply - 24Vdc/150W

Code : B05398

JBSYSTEMS



H

POW246IP2
Power supply 24VDC 6.25A
150W max - IP65 - 2 outputs

Code : H10316

Contest



I

RSP-200-24
Power supply 24VDC
200W max. IP20 - 3 outputs

Code : H10582

Contest



J

DRP240-24
Power supply MW
240W Stabilized, for DIN rail

Code : H9927

Contest



K

RSP-320-24
Power supply 24VDC
320W max. IP20 - 3 outputs

Code : H10583

Contest



L

DRP480-24
Power supply MW
480W Stabilized, for DIN rail

Code : H9928

Contest

WHAT LENGTH OF RIBBON?

The maximum ribbon length is not determined solely by the power of the power supply and the driver. It is also determined by the current intensity that can be supported by the ribbon circuit. You will be able to double the maximum length referenced in the table below by powering the ribbon at both ends.



		Max Length
9859	COLOURTAPE3065	16 m
10541	COLOURTAPE6020	8 m
10542	COLOURTAPE6020-WARM	5 m
9994	COLOURTAPE6065	8 m
9860	COLOURTAPE6067	8 m
10543	COLOURTAPE6067-WARM	5 m
10539	PURETAPE12020-WARMCOLD	5 m
10540	PURETAPE12067-WARMCOLD	5 m
10538	PURETAPE14420-COLD	5 m
10536	PURETAPE14420-WARM	5 m
10537	PURETAPE6020-COLD	8 m
10535	PURETAPE6020-WARM	8 m
9862	PURETAPE6067-COLD	8 m
9861	PURETAPE6067-WARM	8 m

	Reference	Code	Output voltage	Intensity	Power	Number of outputs	Format	IP	Dimensions
A	POW241IP	H9881	24V	1 A	30 W	1	-	IP65	218 x 30 x 22
B	EIP 060V0240LS	B05390		2.5 A	60W	1	-	IP20	157 x 54 x 36
C	POW242	H9807		2.1 A	50 W	1	-	IP20	125 x 52 x 36
D	POW244IP2	H10362		4 A	100 W	2	-	IP65	240 x 68 x 57
E	LRS-100-24	H10581		4.5A	100 W	2	A integrate	IP20	129 x 97 x 30
F	DR120-24	H9926		5 A	120 W	2	Rail	IP20	65.5 x 125.2 x 100
G	ESE 150-24S	B05398		6.25 A	150 W	2	A integrate	IP20	159 x 97 x 30
H	POW246IP2	10316		6.5 A	150 W	2	-	IP65	240 x 68 x 57
I	RSP-200-24	10582		8.4 A	200 W	3	A integrate	IP20	215 x 115 x 30
J	DRP-240-24	9927		10 A	240 W	2	Rail	IP20	125.5 x 125.2 x 100
K	RSP-320-24	10583		13.4 A	320 W	3	A integrate	IP20	215 x 115 x 3
L	DRP-480-24	9928		20 A	480 W	2	Rail	IP20	227x125,2x100
M	LRS-200-5	H10971		5V	40A	200W	3	A integrate	IP20



HOW TO CHOOSE A POWER SUPPLY?

What is the consumption of a ribbon in W and which power supply should I choose?

Example:

9m of RGB ribbon with 60 LEDs/m 14.4 W/m in 24 V (COLOURTAPE6065)

Consumption of a length L of ribbon (in W) = length (m) x power/meter (w/m)
The ribbon will consume $14.4 \times 9 = 129.6$ W

Power supply choice:

An additional 10% of power must be added to the power supply.

In the same example:
 $129.6 + 10\% = 142.56$ W

POW246IP2 which is 150W

ALUMINUM PROFILES

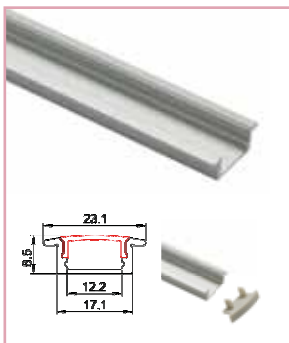

TAPEprofil-A
Built-in aluminum profile 8.5 x 23 mm
2m Length

Code : H10619

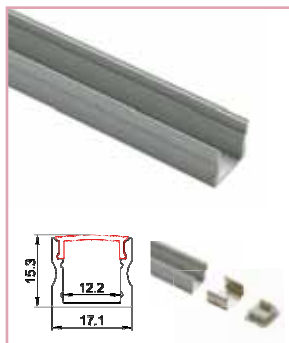

TAPEprofil-B
Aluminium profile 15 x 17 mm
2m Length

Code : H10620

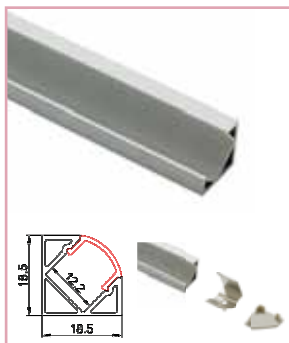

TAPEprofil-C
Aluminium profile 19 x 19 mm 45°
2m Length

Code : H10621



TAPEprofil-D
Double width aluminum profile 15 x 24 mm
2m Length

Code : H10622

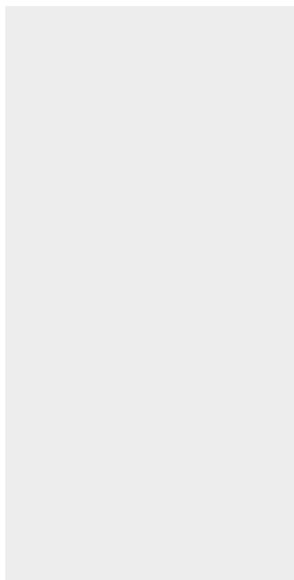

TAPEclip-B
Fastening clip for B profile

Code : H10633



TAPEclip-C
Fastening clip for C profile

Code : H10634



TAPEclip-D
Fastening clip for D profile

Code : H10635



TAPEcaps-A
Termination cap for profile A

Code : H10629



TAPEcaps-B
Termination cap for profile B

Code : H10630



TAPEcaps-C
Termination cap for profile C

Code : H10631



TAPEcaps-D
Termination cap for profile D

Code : H10632





TAPEcov-1
Crystal diffuser for profiles A,B,C
2m Length

Code : H10623

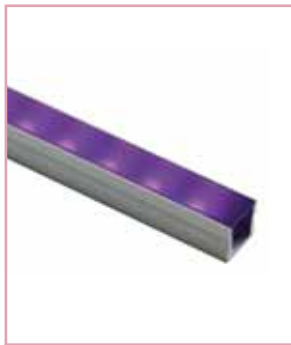

TAPEcov-2
Frost diffuser for profiles A,B,C
2m Length

Code : H10624



TAPEcov-3
Milk diffuser for profiles A,B,C
2m Length

Code : H10625



TAPEcov-4
Crystal diffuser for profile D
2m Length

Code : H10626



TAPEcov-5
Frost diffuser for profile D
2m Length

Code : H10627



TAPEcov-6
Milk diffuser for profile D
2m Length

Code : H10628



**ALU-CORNER-15MM
(2M)**
Corner profile

Code : B05376



**ALU-RECESS-15MM
(2M)**
Built-in high profile

Code : B05371



**ALU-SURFACE-7MM
(2M)**
Low profile

Code : B05372



**ALU-SURFACE-15MM
(2M)**
High profile

Code : B05374



THE TYPES OF LIGHT DIFFUSION

Milk - Opaline diffuser
Diffusion, it makes it possible to make signage. You do not see the LEDs

Frost - 50% diffusing
Ambient lighting. It diffuses the light (if the chosen profile is deep enough).

Crystal - Transparent
For lighting, it protects LEDs
Using the cover will attenuate the brightness of the ribbon according to its opacity.



ACCESSORIES FOR RIBBONS



TCO-2
T connector for 10 mm monochrome ribbons

Code : H10549



TCO-3
T connector for 2-colour 10 mm ribbons

Code : H10552



TCO-4
T connector for 10 mm 3-colour ribbons

Code : H10555



TCO-5
T-connector for 12 mm 4-colour ribbons

Code : H10558



XCO-2
X connector for 10 mm monochrome ribbons

Code : H10550



XCO-3
X connector for 2-colour ribbons 10 mm

Code : H10553

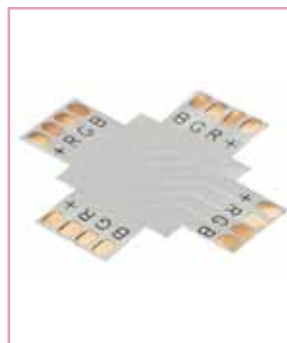

XCO-4
X connector for 10 mm 3-colour ribbons

Code : H10556

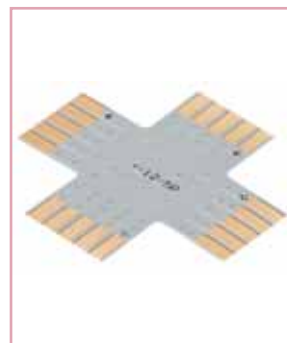

XCO-5
X connector for 12 mm 4-colour ribbons

Code : H10559



LCO-2
L-connector for 10 mm monochrome ribbons

Code : H10548



LCO-3
L-connector for 2-colour ribbons 10 mm

Code : H10551



LCO-4
L-connector for 10 mm 3-colour ribbons

Code : H10554



LCO-5
L-connector for 12 mm 4-colour ribbons

Code : H10557



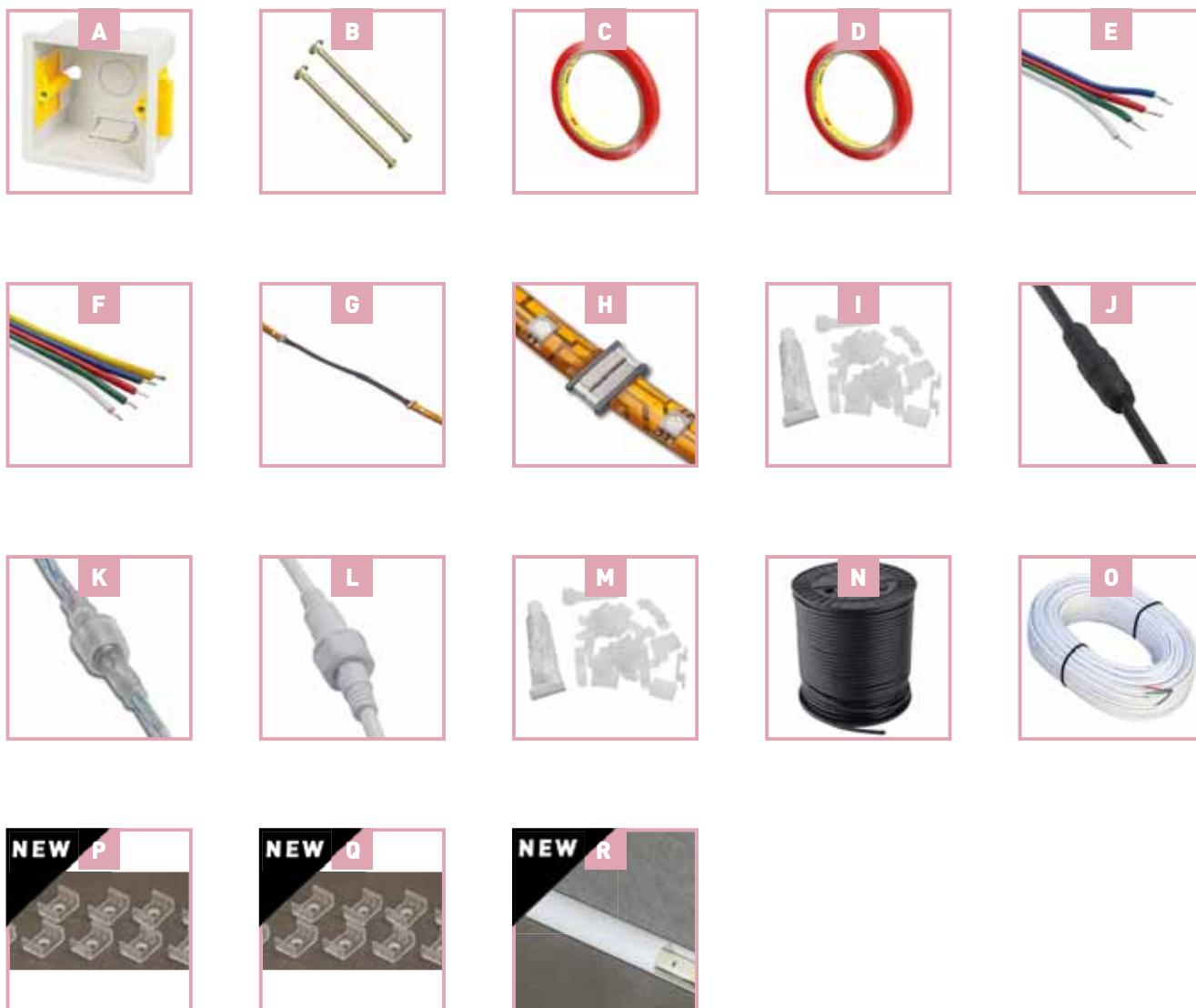

A	H10637	PILOTBOX - Recessed square box 47 mm white	CONTEST®	
B	H10638	PILOTSCREW - Screw steel size M3.5x20 - 1 piece (2 are needed by PILOTBOX)	CONTEST®	
C	H10544	ADF1050 - Double sided adhesive width 10 mm - roll of 50 m	CONTEST®	
D	H10545	ADF1250 - Double sided adhesive width 12 mm - roll of 50 m	CONTEST®	
E	H10546	FLATCABLE-4 Flat cable 4 x 0.326mm ² N/G/R/B - 10m	CONTEST®	
F	H10547	FLATCABLE-5 - Flat cable 5 x 0,326mm ² N/G/R/B/Y- 10m	CONTEST®	
G	H9887	TAPELINK20 - 4-wire cords with F/F-IP20 connectors	CONTEST®	
H	H9888	TAPECON4FF - 4-pin connector F / F-IP20 pack of 20	CONTEST®	
I	H9883	TAPEFIX65 - Set of 15 bridges, 5 endcaps, 1 Silicone Tube	CONTEST®	
J	H9884	TAPELINK61 - 4-wire cords with M/F-IP61 connectors - black	CONTEST®	
K	H9885	TAPELINK65 - Connect 4-wire cords. M/F-IP65 - transparent	CONTEST®	
L	H9886	TAPELINK68 - 4-wire cords M/F-IP68 connectors - white	CONTEST®	
M	H9882	TAPEFIX68 - Set of 15 bridges, 5 endcaps, 1 Silicone Tube	CONTEST®	
N	H9808	RGBB-100 - 4-wire electric cable for 3-colour ribbons of 50 meter	CONTEST®	
O	B04944	CCM-50 - Cable to connect LED projectors to the output of our LED drivers	JB SYSTEMS®	
P	B05373	ALU-SURFACE-7MM-CLIPS - ALU profile, clips surface mounting	JB SYSTEMS®	
Q	B05375	ALU-SURFACE-15MM-CLIPS - ALU profile opal, clips surface mou	JB SYSTEMS®	
R	B05377	ALU-CORNER-15MM-CLIPS - ALU profile opal, clips surface corn	JB SYSTEMS®	

Ribbon type



Monochrome/UV/Blue

W/WW

RGB

RGBW



PILOTdrive-1	H10560	✓	-	-	-
PILOTdrive-2	H10561	-	✓	-	-
PILOTdrive-3	H10562	-	-	✓	-
PILOTdrive-4	H10563	-	-	-	✓
PilotTOUCH	H9809	-	-	✓	-
TAPEDIMMER	H9866	✓	-	-	-
LED 1CH DIM WALL	B05392	✓	-	-	-
LED 1CH DIM-CONTROL	B05393	✓	-	-	-
TAPEDRIVER-1	H10573	✓	-	-	-
LED DMX-CONTROL SCREW MK2	B05394	-	-	✓	-
TAPEDRIVER-3	H10574	✓	✓	✓	-
TAPEDRIVER-4	H10575	✓	✓	✓	✓
TAPEDRIVER-12	H10576	✓	✓	✓	✓
POWTAPE	H9583	-	-	✓	-
MICRO LED MANAGER Mk2	B04936	-	-	✓	-
MINI LED MANAGER Mk3	B04949	-	-	✓	-
TAPEDRIVER-RF3	H10577	✓	-	✓	-
TAPEDRIVERTOUCH-RF3	H10578	-	-	✓	-
TAPEDRIVER-RF4	H10579	-	-	-	✓
TAPEDRIVER-WIFI4	H10580	✓	✓	✓	✓
LED RF-CONTROL DIM	B05396	✓	-	-	-
LED RF-CONTROL RGB	B05397	-	-	✓	-
TAPELIVE4	H10572	✓	✓	✓	✓

	TAPERIVER-RF3 10577	TAPERIVERTOUCH- RF3 10578	TAPERIVER-RF4 10579	TAPERIVER-WIFI4 10580	TAPELIVE4 10572	TAPERIVER1 10573	TAPERIVER3 10574	TAPERIVER4 10575	TAPERIVER12 10576	MINI LED MANAGER MK3 B04949	POWTAPE H9583	MICRO LED MANAGER MK2 B04950
REMOTERF-8W 10569	✓											
REMOTERF-10RGB 10570	✓	✓										
REMOTERF-8RGBW 10571			✓									
PILOTctl-1 10564				✓		✓						
PILOTctl-2 10565				✓			✓					
PILOTctl-3 10566				✓			✓					
PILOTctl-4 10567				✓				✓				
PILOTctl-16 10568				✓				✓	✓			
Pilot-TOUCH 9809												
Téléphone/Tablette					✓							
TAPELIVE4 10572				✓								
Contrôle DMX						✓	✓	✓	✓	✓	✓	✓
CTLTAPE H9584											✓	✓
LED WALL DIMMER B04936											✓	✓
LEDCON-02 MK2 B04660											✓	✓



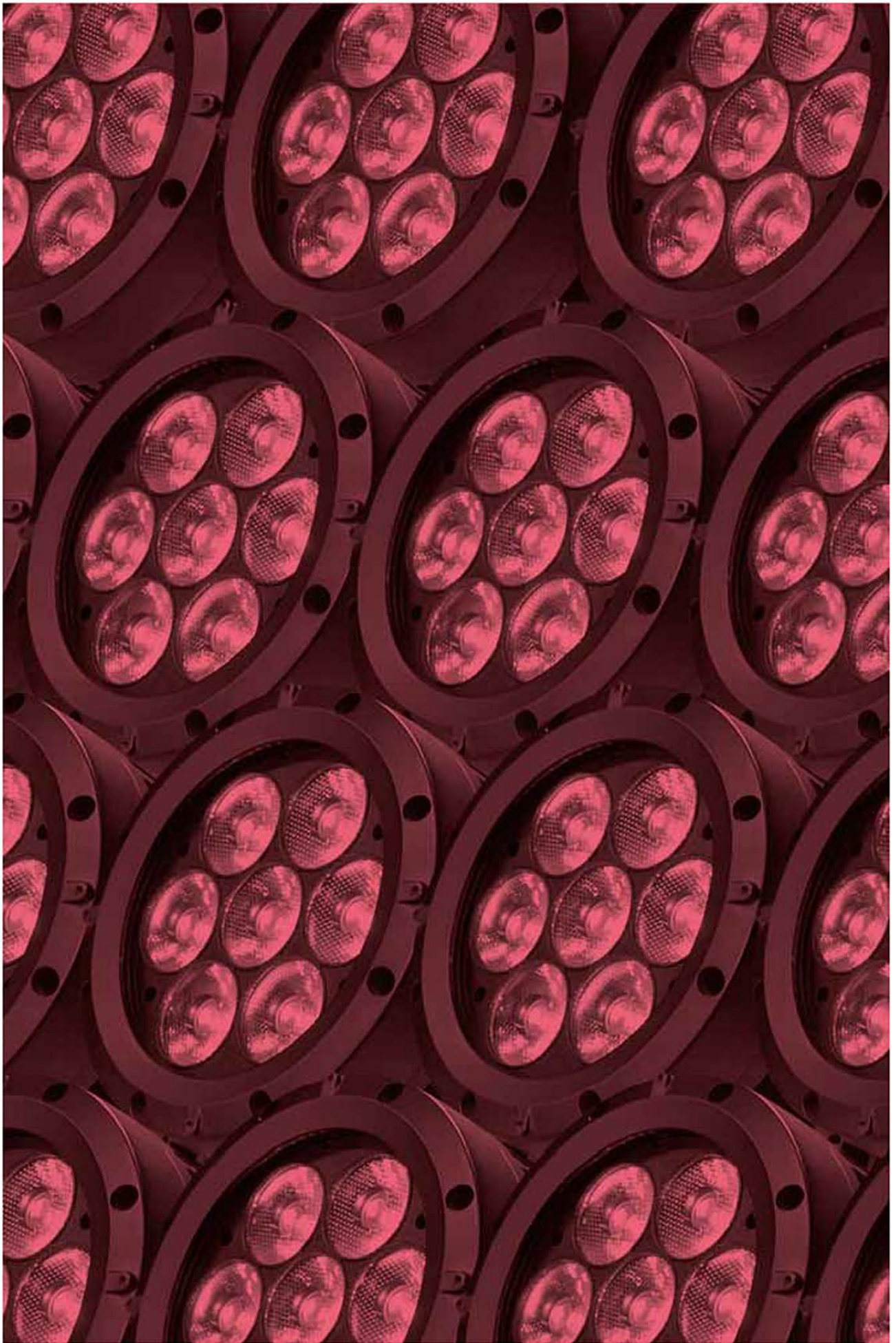

LIGHTING

ARCHITECTURE PROJECTORS
AMBIENT PROJECTORS
BATTERY PROJECTORS
SCENOGRAPHY PROJECTORS
FLAT PROJECTORS
PAR PROJECTORS
PANELS, BLINDERS AND FLOOD
MOVING HEADS
SCANNERS
ANIMATION EFFECTS
LASERS
STROBES
BLACK LIGHT
MIRROR BALLS
CONTROLLERS
ELECTRICAL DISTRIBUTION

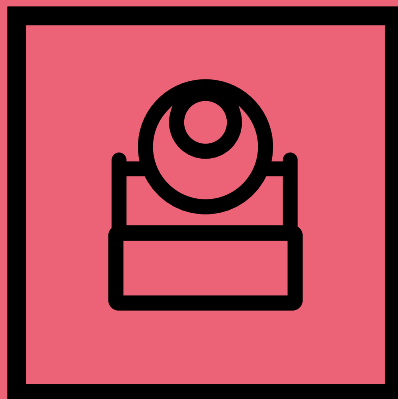

ARCHITECTURE PROJECTORS

Designed for installation

The projectors of the IPZOOM, IPSPOT and BT-ColoRay range are equipped with ergonomics perfectly adapted to fixed or temporary installations. Their robust cast aluminium and IP65 housing allow for continuous use outdoors. The air valve avoids condensation and removes moisture from the projector.

The bright OLED or LCD display allows you to visualize & set the different menu options manually. Thanks to the use of touch buttons a waterproof barrier is maintained, without wear of buttons.



Tight connections

IPZOOM's such as IPSPOT and BT-ColoRay are equipped with inputs and outputs dedicated to the power supply and DMX link. In order to improve discretion and ease of wiring, the IPZOOMs are equipped with waterproof chassis and plugs.

Chassis sealing is ensured by plugs. In addition to the adapters supplied, you will find a whole range of optional cables and plugs in order to make waterproof connections to other products from our range.



IPZOOM7x15QC
Waterproof projector with 7x15W RGBW 4-in-1 LEDs

Code : H10657



Optics: 7x15W RGBW LEDs
Zoom opening angle: 12° to 45°
Integrated control unit with OLED touch panel display with drop-down menu SEETRONIC® DMX IN and OUT 3- and 5-pin plugs with waterproof plug SEETRONIC®POWER IN/OUT 3-pole plugs with waterproof plug
Power supply: 100-240V/50-60Hz
Power consumption: 130W
Waterproofing level: IP65
Natural convection cooling
Depressurisation valve with waterproof membrane
Finish: cast aluminium painted black
Dimensions: 270 x 320 x 320 mm
Weight: 9.9 kg



IPZOOM3x15QC
Waterproof projector with 3x15W RGBW 4-in-1 LEDs

Code : H10656



Optics: 3x15W RGBW LEDs
Zoom opening angle: 12° to 45°
Integrated control unit with OLED touch panel display with drop-down menu SEETRONIC® DMX IN and OUT with 3- and 5-pin XLR plugs with waterproof plug SEETRONIC®POWER IN/OUT 3-pole plugs with waterproof plug
Power supply: 100-240V/50-60Hz
Power consumption: 70W
Waterproofing level: IP65
Natural convection cooling
Depressurisation valve with waterproof membrane
Finish: cast aluminium painted black
Dimensions: 245 x 250 x 270 mm
Weight: 5.8 kg

NEW



BT-ColoRay 18FCR
LED proj. 144W RGBW 20° (IP-POWER)

Code : B05512



Optics: 8x18W RGBW LED
Opening angle: 20°
Integrated control unit with LCD display with drop-down menu DMX IN and OUT with 5-pin XLR plugs with waterproof plug
POWER IN/OUT with original NEUTRIK PowerCon® TRUE1 connectors
Power supply: 100-240V/50-60Hz
Power consumption: 129 W
Waterproofing level: IP65
Waterproof fan
Depressurisation valve with waterproof membrane
Finish: cast aluminium painted black
Dimensions : 305 x 273 x 192 mm
Weight : 5,28 kg



BT-ColoRay 120R
LED proj. 120W RGBW COB 13° RENTAL (IP-POWER)

Code : B05509



Optics: 1x 120W RGBW COB LED
Opening angle: 25°
Integrated control unit with LCD display with drop-down menu DMX IN and OUT with 5-pin XLR plugs with waterproof plug
POWER IN/OUT with original NEUTRIK PowerCon® TRUE1 connectors
Power supply: 100-240V/50-60Hz
Power consumption: 129 W
Waterproofing level: IP65
Waterproof fan
Depressurisation valve with waterproof membrane
Finish: cast aluminium painted black
Dimensions: 304 x 188 x 272 mm
Weight: 4.8 kg

NEW



IP65 60W RGBW 25°

BT-ColoRay 60R
LED proj. 60W RGBW 13° RENTAL COB (IP-POWER)

Code : B05510



Optics: 1x 60W RGBW COB LED
Opening angle: 25°
Integrated control unit with LCD display with drop-down menu
DMX IN and OUT with 5-pin XLR plugs with waterproof plug
POWER IN/OUT with original NEUTRIK PowerCon® TRUE1 connectors
Power supply: 100-240V/50-60Hz
Power consumption: 70 W
Waterproofing level: IP65
Waterproof fan
Depressurisation valve with waterproof membrane
Finish: cast aluminium painted black
Dimensions: 304 x 188 x 272 mm
Weight: 4.8 kg



IP65 120W RGBWA 23°

IPSPOT12x10FIVE
Projector with 12x10W - IP65 FIVE LEDs

Code : H10793



Optics: 12x10W RGBWA LED
Opening angle: 23°
Integrated control unit with LCD display with drop-down menu
SEETRONIC® DMX IN and OUT 3- and 5-pin plugs with waterproof plug
SEETRONIC® POWER IN/OUT 3-pole plugs with waterproof plug
Power supply: 100-240V/50-60Hz
Power consumption: 125 W
Waterproofing level: IP65
Natural convection cooling
Depressurisation valve with waterproof membrane
Finish: cast aluminium painted black
Dimensions: 261 x 240 x 249 mm
Weight: 9.9 kg



IP65 70W RGBWA 23°

IPSPOT7x10FIVE
Projector with 7x10W - IP65 FIVE LEDs

Code : H10792



Optics: 7x10W RGBWA LED
Opening angle: 23°
Integrated control unit with LCD display with drop-down menu
SEETRONIC® DMX IN and OUT with 3-pin XLR plugs with waterproof plug
SEETRONIC® POWER IN/OUT 3-pole plugs with waterproof plug
Power supply: 100-240V/50-60Hz
Power consumption: 75 W
Waterproofing level: IP65
Natural convection cooling
Depressurisation valve with waterproof membrane
Finish: cast aluminium painted black
Dimensions: 188 x 273 x 282 mm
Weight: 5.8 kg



NEW



PROJECTOR CASE 3
Can contain 6 projectors (BT-Coloray series, Stage Beamer, Pro Beamer, BT-Smartzoom)

Code : B05510



Architecture projector connections				
A	H10716	SC3FXX-W - Seetronic female 3P XLR IP65 waterproof plug		SEETRONIC®
B	H10717	SC3MXX-W - Seetronic male 3P XLR IP65 waterproof plug		SEETRONIC®
C	H10718	SC5FXX-W - Seetronic female 5P XLR IP65 waterproof plug		SEETRONIC®
D	H10719	SC5MXX-W - Seetronic male 3P XLR IP65 waterproof plug		SEETRONIC®
F	H10721	SAC3MX - Seetronic Power Out IP65 waterproof plug		SEETRONIC®
G	H10722	IPCD-1 - DMX 3P waterproof connection cord - 1m	NEW 2018	HILEC®
	H10723	IPCD-2 - DMX 3P waterproof connection cord - 2m	NEW 2018	HILEC®
	H10724	IPCD-5 - DMX 3P waterproof connection cord - 5m	NEW 2018	HILEC®
H	H10725	IPCP-1 - Waterproof electrical connection cord - 1m	NEW 2018	HILEC®
	H10726	IPCP-2 - Waterproof electrical connection cord - 2m	NEW 2018	HILEC®
	H10727	IPCP-5 - Waterproof electrical connection cord - 5m	NEW 2018	HILEC®



ARCHITECTURE PROJECTORS

At a time when new LED sources compete with traditional lamps, surpassing them in many areas, we offer you a new approach to lighting, focused on the quality of diffused light and easy colour control.





BT-ULTRAZOOM
180W RGBW LED projector with 4°-40° motorised zoom (IP65).

Code : B04396



Optics: 1x180W RGBW LED
Zoom opening angle: 4° to 40°
Integrated control unit with OLED touch panel display with drop-down menu SEETRONIC® DMX IN and OUT 3- and 5-pin plugs with waterproof plug SEETRONIC®POWER IN/OUT
3-pole plugs with waterproof plug
Power supply: 100-240V/50-60Hz
Power consumption: 180W
Waterproofing level: IP65
Natural convection cooling
Depressurisation valve with waterproof membrane
Finish: cast aluminium painted black
Dimensions: 250 x 312 x 404 mm
Weight: 9.15 kg





BT-SMARTZOOM
120W RGBW LED projector with motorized zoom [4° to 36°] (IP65).

Code : B04397

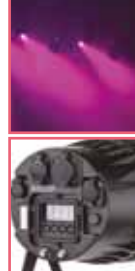

Optics: 1x120W RGBW LED
Zoom opening angle: 4° to 36°
Integrated control unit with OLED touch panel display with drop-down menu SEETRONIC® DMX IN and OUT 3- and 5-pin plugs with waterproof plug SEETRONIC®POWER IN/OUT
3-pole plugs with waterproof plug
Power supply: 100-240V/50-60Hz
Power consumption: 130W
Waterproofing level: IP65
Natural convection cooling
Depressurisation valve with waterproof membrane
Finish: cast aluminium painted black
Dimensions: 274 x 388 x 210 mm
Weight: 7.7 kg

PRO BEAMER ZOOM - RENTAL
8° - 40° motorised zoom

Code : B04399



Optics: 7x12W RGBW LEDs
Two zones (outer ring + centre)
Zoom opening angle: 8° to 40°
Integrated control unit with display with drop-down menu
SEETRONIC® DMX IN and OUT with 3-pin XLR plugs with waterproof plug SEETRONIC®POWER IN/OUT
3-pole plugs with waterproof plug
Power supply: 100-240V/50-60Hz
Power consumption: 128W
Waterproofing level: IP66
Natural convection cooling
Depressurisation valve with waterproof membrane
Finish: cast aluminium painted black
Dimensions: 355 x 191 x 236 mm
Weight: 7.3 kg





BARN-PRO BEAMER ZOOM

Code : B04391



Four-leaf barndoor:
Compatible with PRO BEAMER ZOOM - RENTAL

STAGE BEAMER FC - OUTDOOR
14x5W RGBW 14° - IP65

Code : B05511



Optics: 14x5W RGBW LEDs
Opening angle: 14°
Integrated control unit with display with drop-down menu
Waterproof wiring for power supply inputs/outputs and DMX inputs/outputs
Power supply: 100-240V/50-60Hz
Power consumption: 65W
Waterproofing level: IP65
Natural convection cooling
Finish: cast aluminium painted black
Dimensions: 245 x 205 x 245 mm
Weight: 4.96 kg



Find the power and signal cords on the previous page



STAGE BEAMER FC – INDOOR
LED proj. 14x5W RGBW 14°

Code : B05504



Optics: 14x5W RGBW LEDs
Opening angle: 14°
Integrated control unit with display with drop-down menu
DMX IN / OUT with 3- and 5-pin XLR plugs
POWER IN/OUT with Powercon plugs
Power supply: 100-240V/50-60Hz
Power consumption: 65W
Natural convection cooling
Finish: cast aluminium painted black
Dimensions: 245 x 205 x 245 mm
Weight: 4.96 kg



BARN-STAGE BEAMER
Stage Beamer barndoor

Code : B04342



Stage beamer four-leaf barndoor



48x3W RGBW MEGA BEAM
Mk3 LED

Code : B04395



Optics: 48x3W LEDs
12 red, 12 green, 12 blue, 12 white
Opening angle: 15°
Integrated control unit with display with drop-down menu
Waterproof wiring for power supply inputs/outputs and DMX inputs/outputs
Power supply: 100-240V/50-60Hz
Power consumption: 180W
Waterproofing level: IP66
Natural convection cooling
Finish: cast aluminium painted black
Dimensions: 305 x 276 x 230 mm
Weight: 10.3 kg





MINI BEAMER OUT-DOOR
RGB LED 7x3W tricolour LEDs.

Code : B04357



Optics: 7x3W RGB LEDs
Opening angle: 16°
Integrated control unit with display with drop-down menu
Waterproof wiring for power supply inputs/outputs and DMX inputs/outputs
Power supply: 100-240V/50-60Hz
Power consumption: 27W
Waterproofing level: IP65
Natural convection cooling
Depressurisation valve with waterproof membrane
Finish: cast aluminium painted black
Dimensions: 220 x 175 x 228 mm
Weight: 5.48 kg



EZ-SPOT15 OUTDOOR
15W RGBW LED projector

Code : B05131



Optics: 1x15W RGBW LED
Opening angle: 10°
Infrared remote control IR-3
Power supply: 100-240V/50-60Hz
Power consumption: 27W
Waterproofing level: IP65
Natural convection cooling
Finish: cast aluminium painted black
Dimensions: 152 x 133 x 90 mm
Weight: 1.31 kg



NEW





EZ-SPOT15 WW OUTDOOR
15W Warm White LED Projector

Code : B05141

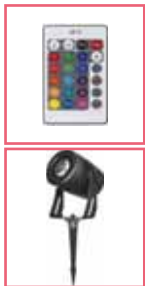

Optics: 1x15W WW LED
Opening angle: 10°
Infrared remote control IR-3
Power supply: 100-240V/50-60Hz
Power consumption: 27W
Waterproofing level: IP65
Natural convection cooling
Finish: cast aluminium painted black
Dimensions: 152 x 133 x 90 mm
Weight: 1.31 kg

Nano Beam / Blue LED
10° LED projector, IP68, 24V (ac/dc)

Code : B04995



Optics: 1x1W Luxeon LED.
The electrical consumption is only 1.7 W.
Stainless steel flange.
Waterproof body (IP68), nickel plated.
Easy and flexible installation.
Power supply: from 6 to 26 volts (AC) from 9 to 35 volts (DC).
Dimensions: Dia 45 x 82 mm
Weight: 0.2 kg



ARCHITECTURE PROJECTORS

Enhance your buildings with all the power of the new CONTEST® IPANELs. Discover the benefit of mixing power with the opening angle.



NEW

IP65
31°

IPANEL24x10QC
Projector with 24x10W QC IP65 LEDs

Code : H10794

Contest®

NEW

FLY4IPANEL
Flight case for 4 IPANEL24x10QC

Code : H10866

Contest®

NEW

IPANEL24x10QC-BARN
Leaves for IPANEL24x10QC

Code : H10889

Contest®

Optics: 24x10W RGBW 4-Zone LEDs
 Opening angle: 31°
 Integrated control unit with display with drop-down menu
 DMX mode from 2 to 20 channels, master/slave, manual mode, presets and integrated show, choice of dimmer curves.
 Waterproof wiring for power supply inputs/outputs and DMX inputs/outputs
 Power supply: 100-240V/50-60Hz
 Power consumption: 240 W
 Waterproofing level: IP65
 Natural convection cooling
 Finish: cast aluminium painted black
 Dimensions: 582 x 270 x 178 mm
 Weight: 15 kg



IP65 **150W**
 COB **60°**

LDP-COBWASH 150TC
150W IP65 COB RVB LED

Code : B05170



Optics: 1x150W RGB COB LED
 Opening angle: 60°
 Infrared remote control
 Integrated control unit with display with drop-down menu
 Waterproof wiring for power supply inputs/outputs and DMX inputs/outputs
 Power supply: 100-240V/50-60Hz
 Power consumption: 170W
 Waterproofing level: IP65
 Natural convection cooling
 Finish: cast aluminium, painted white
 Barndoor included
 Dimensions: 326 x 344 x 220 mm
 Weight: 9.5 kg



IP65 **100W**
 5600K **60°**

100CW LDP-COBWASH
100W white IP65 COB LED projector

Code : B05175



Optics: 1x100W 5600K COB LED
 Opening angle: 60°
 Infrared remote control
 Integrated control unit with display with drop-down menu
 Waterproof wiring for power supply inputs/outputs and DMX inputs/outputs
 Power supply: 100-240V/50-60Hz
 Power consumption: 120 W
 Waterproofing level: IP65
 Natural convection cooling
 Finish: cast aluminium, painted white
 Barndoor included
 Dimensions: 326 x 344 x 220 mm
 Weight: 8.2 kg



IP65 **60W**
 RGB **120°**

LDP-COBWASH 60TC
60W RGB IP65 COB LED projector

Code : B05171



Optics: 1x 60W RGB COB LED
 Opening angle: 120°
 Infrared remote control
 Integrated control unit with display with drop-down menu
 Waterproof wiring for power supply inputs/outputs and DMX inputs/outputs
 Power supply: 100-240V/50-60Hz
 Power consumption: 66W
 Waterproofing level: IP65
 Natural convection cooling
 Finish: cast aluminium, painted white
 Barndoor option available
 Dimensions: 223 x 202 x 122 mm
 Weight: 8.2 kg



ARCHITECTURE PROJECTORS



CW IP65 50W 5600K 120°

LDP-COBWASH 50CW
50W white IP65 COB LED Projector

Code : B05177



Optics: 1x 50W 5600K COB LED
Opening angle: 120°
Infrared remote control
Integrated control unit with display with drop-down menu
Waterproof wiring for power supply inputs/outputs and DMX inputs/outputs
Power supply: 100-240V/50-60Hz
Power consumption: 66W
Waterproofing level: IP65
Natural convection cooling
Finish: cast aluminium, painted white
Barndoor option available
Dimensions: 223 x 202 x 122 mm
Weight: 3.8 kg



WW IP65 50W 3200K 120°

LDP-COBWASH 50WW
50W white COB IP65 LED projector

Code : B05178



Optics: 1x 50W 3200K COB LED
Opening angle: 120°
Infrared remote control
Integrated control unit with display with drop-down menu
Waterproof wiring for power supply inputs/outputs and DMX inputs/outputs
Power supply: 100-240V/50-60Hz
Power consumption: 66W
Waterproofing level: IP65
Natural convection cooling
Finish: cast aluminium, painted white
Barndoor option available
Dimensions: 223 x 202 x 122 mm
Weight: 3.8 kg



LDP-COBWASH 50/60 BARNDOOR

Code : B05191



Barndoor for:
LDP-COBWASH 50WW
LDP-COBWASH 50CW
LDP-COBWASH 60TC.



WW IP65 80W 3000K 120°

LDP-FLOOD80-WW
IP65 projector with white LED

Code : B05117



Optics: 1x80W 3000K COB LED
Opening angle: 120°
Power supply: 100-240V/50-60Hz
Power consumption: 80W
Waterproofing level: IP65
Natural convection cooling
Finish: cast aluminium, painted white
Dimensions: 288 x 360 x 110 mm
Weight: 6.5 kg



WW IP65 50W 3000K 120°

LDP-FLOOD50-WW
IP65 projector with white LED

Code : B05116



Optics: 1x50W 3000K COB LED
Opening angle: 120°
Power supply: 100-240V/50-60Hz
Power consumption: 50W
Waterproofing level: IP65
Natural convection cooling
Finish: cast aluminium, painted white
Dimensions: 290 x 236 x 150 mm
Weight: 3.52 kg



WW IP65 30W 3000K 100°

LDP-FLOOD30-WW
IP65 projector with white LED

Code : B05115



Optics: 1x30W 3000K COB LED
Opening angle: 100°
Power supply: 100-240V/50-60Hz
Power consumption: 30W
Waterproofing level: IP65
Natural convection cooling
Finish: cast aluminium, painted white
Dimensions: 250 x 185 x 126 mm
Weight: 2.3 kg



NEW WW IP65 10W 3000K 120°

LDP-FLOOD10-WW
IP65 projector with white LED

Code : B05114



Optics: 1x10W Bridgelux® LED
Opening angle: 120°
Power supply: 100-240V/50-60Hz
Power consumption: 10W
Waterproofing level: IP65
Natural convection cooling
Finish: cast aluminium, painted white
Dimensions: 115 x 86 x 105 mm
Weight: 0.63 kg



LDP-COLORSTRIP 24FC
Bar with 24x4W RGBW 25° 4-section LEDs - 100cm - IP20

Code : B05144



Optics: 24x4W RGBW 4-section LEDs
Opening angle: 15°
Integrated control unit with display with drop-down menu
Power supply input/output on IEC plug
DMX input/output on XLR 3-pin plug
Power supply: 100-240V/50-60Hz
Power consumption: 85 W
Waterproofing level: IP20
Natural convection cooling
Dimensions: 961 x 56 x 101/122 mm
Weight: 3.6 kg



LDP-COLORSTRIP 12FC
Bar with 12x4W RGBW 15° 2-section LEDs - 50cm - IP20

Code : B05143



Optics: 12x4W RGBW 2-section LEDs
Opening angle: 15°
Integrated control unit with display with drop-down menu
Power supply input/output on IEC plug
DMX input/output on XLR 3-pin plug
Power supply: 100-240V/50-60Hz
Power consumption: 56 W
Waterproofing level: IP20
Natural convection cooling
Dimensions: 479 x 56 x 101/122 mm
Weight: 2.2 kg

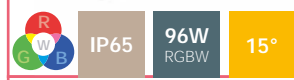

LDP-COLORBAR 24FC
Bar with 24x4W RGBW 15° 2-section LEDs - 96cm - IP20

Code : B05146



Optics: 24x4W RGBW 2-section LEDs
Opening angle: 15°
Integrated control unit with display with drop-down menu
Power supply input/output on IEC plug
DMX input/output on XLR 3-pin plug
Power supply: 100-240V/50-60Hz
Power consumption: 85 W
Waterproofing level: IP65
Natural convection cooling
Dimensions: 960 x 56 x 114/135 mm
Weight: 5 kg

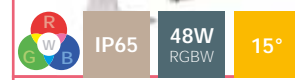

LDP-COLORBAR 12FC
Bar with 12x4W RGBW 15° 2-section LEDs - 48cm - IP20

Code : B05145



Optics: 12x4W RGBW 4-section LEDs
Opening angle: 15°
Integrated control unit with display with drop-down menu
Power supply input/output on IEC plug
DMX input/output on XLR 3-pin plug
Power supply: 100-240V/50-60Hz
Power consumption: 56 W
Waterproofing level: IP65
Natural convection cooling
Dimensions: 460 x 56 x 114/135 mm
Weight: 3.6 kg



ARCHITECTURE PROJECTORS



NEW



IP20

48W
 RGBW

15°



LDP-POWERBAR 12FC
 LED projectors 12x4W RGBW IP65 LEDs.
 Bar length 48 cm

Code : B05134



NEW





IP20

96W
 RGBW

15°

LDP-POWERBAR 24FC
 IP65 LED projector. 24x4W RGBW LEDs. Bar length 96 cm

Code : B05132



LDP-JUNCTION IP68
 Waterproof connection box for the LDP series and other outdoor DMX projectors.

Code : B05112



Optics: 12x4W RGBW LEDs
 Opening angle: 15°
 Integrated control unit with OLED display and backlit touch buttons
 Waterproof wiring for power supply inputs/outputs and DMX inputs/outputs
 Power supply: 100-240V/50-60Hz
 Power consumption: 56W
 Waterproofing level: IP20
 Natural convection cooling
 Depressurisation valve with waterproof membrane
 Finish: cast aluminium painted white
 Dimensions: 480 x 56 x 13.5 mm
 Weight: 3 kg

Optics: 24x4W RGBW LEDs
 Opening angle: 15°
 Integrated control unit with OLED display and backlit touch buttons
 Waterproof wiring for power supply inputs/outputs and DMX inputs/outputs
 Power supply: 100-240V/50-60Hz
 Power consumption: 85W
 Waterproofing level: IP20
 Natural convection cooling
 Depressurisation valve with waterproof membrane
 Finish: cast aluminium painted white
 Dimensions: 960 x 56 x 13.5 mm
 Weight: 5.02 kg





Waterproof connection box for the LDP series and other outdoor DMX projectors. IP68 protection: Outdoor or even underground use.
 Power supply compartment with 3 input outlets
 DMX compartment with 4 input outlets
 Very easy and fast internal connection
 Ideal for the LDP series and any other combination of outdoor power/signal (PowerBeam lighting, LED Blaster, Powerbank, ...)



Light Integration Accessories			
A	B04911	POWERLINK CABLE 1.5 m - Powerlink Cable 1.5M for Outdoor range	HILEC®
B	B04913	POWERLINK CABLE 10m - Powerlink Cable 10m, for Outdoor range	HILEC®
C	B04324	POWERLINK CABLE 5m - Powerlink Cable 5m, for Outdoor range	HILEC®
D	B04908	SIGNAL LINK CABLE 1.5M - Signal Link Cable 1.5m for Outdoor range	HILEC®
E	B04904	SIGNAL LINK CABLE 1.5M - Signal Link Cable 1.5m for Outdoor range	HILEC®
F	B04903	SIGNAL LINK CABLE 5M - Signal Link Cable 5m, for Outdoor range	HILEC®
G	B05157	LDP-Powercable 2M - Power cable L=2m for LDP-POWERBAR, COBWA	HILEC®
H	B05158	LDP-Powercable 5M - Power cable L=5m for LDP-POWERBAR, COBWA	HILEC®

AMBIENT PROJECTORS



TRI4U
Light bar with 4x3W LED tricolour projectors

Code : H9955

Contest 

12x3W RGB LEDs located on 4 projectors
Opening angle: 25° per projector
Independent orientation per projector
Modes of operation:
- DMX
- Standalone
- Musical
- Master / slave
Specially designed hanging bracket with integrated hook for stand
Dimensions: 375 x 160 x 60 mm
Net weight: 2.5 Kg









MINITRUSS-6TCb
Structure decoration projector with 6x3W TRI LEDs

Code : H10365

Contest 

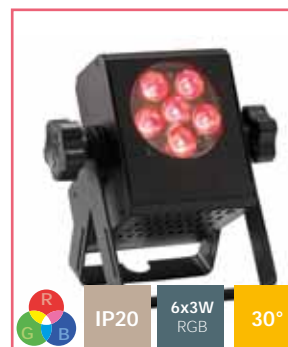
Light source: 6x3W RGB LEDs
Opening angle: 30°
Modes of operation:
- DMX
- Standalone
- Musical
- Master / slave
Input/output on IEC plug
Power supply: 230V - 50Hz
Power consumption: 30W
Dimensions: 135 x 135 x 132 mm
Net weight: 1.4 kg











MINICUBE-6TCb
Compact projectors with 6x3W satin TRINoir LEDs

Code : H10147

Contest 

Light source: 6x3W RGB LEDs
Opening angle: 30°
Modes of operation:
- DMX
- Standalone
- Musical
- Master / slave
DMX input and output
Power supply: AC 100/240V - 50/60Hz
Power consumption: 30 W
Dimensions: 166 x 180 x 110 mm
Net weight: 1.35 kg





LED ROTOGOBO
60W gobos LED projector

Code : B04528

JBSYSTEMS

A powerful 60W white LED motif projector
Low gobo temperature: no need for expensive thermo-resistant glass or metal gobos!
Usable with plastic gobos created by a simple laser printer!
Metal and glass gobos are of course always usable.
Easy adjustment by rotary knobs on the back of the projector:
Rotation speed control of the gobo
Dimmer switch to adjust light intensity
Beam angle: 18°
Dimensions: 236 x 234 x 206 mm
Weight: 3.4 kg







Artist10W
10W gobo LED projector

Code : H10651

Contest 

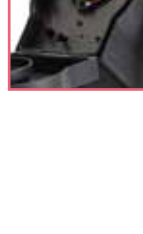
1x10W white LED
Adjustment of rotation speed
Power, stop and auto off timer button
Power consumption: 12W maximum
Power supply: AC 100/240V - 50/60Hz with 12V DC adapter provided
Water resistant plastic case
Suspension moving head, table support cup and floor mounting pin
Dimensions: 170 x 140 x 240 mm
Weight: 0.700 kg



BATTERY PROJECTORS



IP65 **5x12W**
RGBWAUV **25°**

IPair5x12Six
IP65 AirDMX battery projector

Code : H10411



Optics: 5x12W RGBWAUV LEDs
Opening angle: 25°
AirDMX integrated transmitter / receiver
Compatible with AirBox-ER1
Integrated control unit with display with drop-down menu
Infrared remote control
DMX IN and OUT with 3-pin IP plugs
POWER IN/OUT with 4-pin IP plugs
Power supply: 100-240V/50-60Hz





FLY-IPairx6
Flight case for 6 IPair5x12Six

Code : H10464

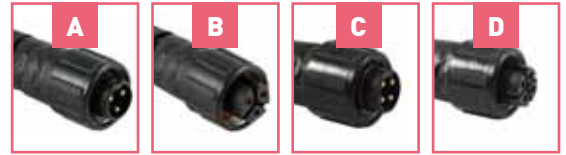

Power consumption: 65 W
12-cell 22.2V 4.4Ah lithium battery
Battery life: 6 hours in color changing mode - 4 hours in white [RGB]
Waterproofing level: IP65
Finish: cast aluminium painted black
Dimensions: 240 x 165 x 280 mm
Weight: 3.5 kg



A	H10465	FICIP-DMXm - DMX male waterproof plug for IPAir- IP68	
B	H10466	FICIP-DMXF - DMX female waterproof plug for IPAir- IP68	
C	H10467	FICIP-POWm - Male waterproof power plug for IPAir- IP68	
D	H10468	FICIP-POWf - Female waterproof power plug for IPAir- IP68	





IP65 **6x10W**
RGBWA **25°**

BT-AKKULITE IP
Outdoor 6x10W RGBWA 5in1 LED projector + infrared remote control

Code : B05135

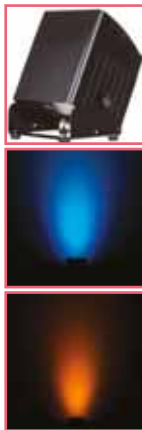

Optics: 6x10W RGBWA LEDs
Opening angle: 22°
Wireless transmitter / receiver compatible with protocol W-DMX G4
Integrated control unit with display with drop-down menu
Infrared remote control
DMX IN / OUT with 3-pin XLR, POWER IN by Pro Con (Seetronic)
Waterproofing level: IP65
Power supply: 100-240V/50-60Hz Battery
Power consumption: 60 W
Dimensions: 180 x 150 x 198 mm
Weight: 4.5 kg



IP20 **6x10W**
RGBWA **22°**

ACCU COLOR-WHITE
Battery powered LED projector, built around 6 RGBWA (10W) LEDs

Code : B05126



Optics: 6x10W RGBWA LEDs
Opening angle: 22°
Wireless transmitter / receiver compatible with protocol W-DMX G4
Integrated control unit with display with drop-down menu
Infrared remote control
DMX IN and OUT with 3-pin XLR, POWER IN/OUT with Powercon
Power supply: 100-240V/50-60Hz Battery
Power consumption: 60 W
Finish: white
delivered with a transparent plastic cover
Dimensions: 167 x 138 x 185 mm
Weight: 4.14 kg



IP20 **6x10W**
RGBWA **22°**

ACCU COLOR-BLACK
Battery powered LED projector, built around 6 RGBWA (10W) LEDs

Code : B05128



Optics: 6x10W RGBWA LEDs
Opening angle: 22°
Wireless transmitter / receiver compatible with protocol W-DMX G4
Integrated control unit with display with drop-down menu
Infrared remote control
DMX IN and OUT with 3-pin XLR, POWER IN/OUT with Powercon
Power supply: 100-240V/50-60Hz Battery
Power consumption: 60 W
Finish: black
delivered with a transparent plastic cover
Dimensions: 167 x 138 x 185 mm
Weight: 4.14 kg





CASE-3
Flight case for 6x BT-AKKULITE IP / ACCUCOLOR

Code : B03274



CASE FOR 4x ACCU DECOLITE
Flight case for 4x Accu Decolite

Code : B03279



RGB IP20 15W RGBW 30°

ACCU DECOLITE
A battery powered LED projector, built around RGB + White 15W LED, with embedded wireless DMX

Code : B05127



RGBW IP65 15W RGBW 10°

ACCU DECOLITE IP
A battery powered IP65 LED projector, built around 15W RGB + White LED, with embedded wireless DMX

Code : B05136



Optics: 1x15W RGBW LED
Opening angle: 10 to 25°
Wireless transmitter / receiver compatible with protocol W-DMX G4
Integrated control unit with display with drop-down menu
Infrared remote control
Power supply: 100-240V/50-60Hz Battery
Power consumption: 15 W
Dimensions: 168 x 138 x 62 mm
Weight: 1.61 kg

Optics: 1x15W RGBW LED
Opening angle: 10°
Wireless transmitter / receiver compatible with protocol W-DMX G4
Integrated control unit with display with drop-down menu
Infrared remote control
Power supply: 100-240V/50-60Hz
Power consumption: 15 W
Dimensions: 172 x 138 x 185 mm
Weight: 1.61 kg



ACCU DECOLITE IP BALL 25CM
Acrylic ball 25cm for ACCU DECOLITE IP - outdoor

Code : B05140



ACCU DECOLITE IP TUBE 50CM
50cm acrylic tube for Accu Decolite IP

Code : B05137



100CM ACCU DECOLITE IP TUBE
100cm acrylic tube for Accu Decolite IP

Code : B05138



150CM ACCU DECOLITE IP TUBE
150cm acrylic tube for Accu Decolite IP

Code : B05139



SCENOGRAPHY PROJECTORS

"The scenographer is the one who composes with volumes, objects, colours, lights and textures".

This term "scenographer" consists of three major categories:

- The scenographer of a show who puts on a show or a particular event.
- The scenographer of equipment who designs a place intended to host live shows or various events.
- The scenographer of exhibitions who intervenes in the field of museums and exhibitions.

EQUIPMENT FOR PERMANENT OR TEMPORARY EXHIBITION

A high performance, a very long life and low power consumption allow the LED source to integrate compact, aesthetic and efficient projectors.

They will enhance all kinds of places and surfaces while respecting the subjects lit.

STAGE EQUIPMENT FOR LIVE PERFORMANCE

Economical in energy and easy to install, the products of the ScenoGraFX range are ideal lighting solutions for the optimisation of all your events

The projectors in the range offer lighting quality and dimming that are identical to filament lamps thanks to the different built-in dimmer modes.

LED LIGHT SOURCES

The LED light sources provide new solutions in many areas. Currently, LEDs are used for theatrical, architectural and event lighting.

Building on the success of their range of animation projectors, Contest® and Briteq® develop this technology with the creation of a new range of projectors designed to produce exceptional brightness with great optical and ergonomic quality.





CW 370W
6500K 20°

EXPO CANNON
370 W cool white CREE LED projector

Code : B05133



Optics: 37x10W 6500K CREE LED
Opening angle: 20°
Brightness of 26953 Lux at 4m
Integrated control unit with OLED LCD Display with drop-down menu
DMX IN / OUT with XLR 3-pin plugs,
POWER IN/OUT with NEUTRIK powerCON®
Power supply: 100-240V/50-60Hz
Power consumption: 380 W heat sink and silent fan.
Finish: Black extruded aluminium
Frost filter and barndoor included
Dimensions: 295 x 315 x 377 mm
Weight: 6.2 kg





WW 150W
3200K 90°
x113°

SFX-H0150W
150W warm white asymmetrical floodlight type COB LED projector

Code : H10702



Optics: 1x150W 3200K COB LED
Opening angle: 90°x113°
Brightness of 530 Lux at 4m
Integrated control unit with LCD display with drop-down menu
DMX IN / OUT with XLR 3-pin plugs,
POWER IN/OUT with powerCON plugs
Power supply: 100-240V/50-60Hz
Power consumption: 155 W heat sink and silent fan.
Finish: Black
Delivered with barndoor, filter frame
Dimensions: 295 x 315 x 377 mm
Weight: 6.2 kg

150W
RGBW 90°
x113°

SFX-H0150QC
150W RGBW asymmetrical floodlight type COB LED projector

Code : H10701



Optics: 1x150W RGBW COB LED
Opening angle: 90°x113°
Brightness of 289 Lux at 4m
Integrated control unit with LCD display with drop-down menu
DMX IN / OUT with XLR 3-pin plugs,
POWER IN/OUT with powerCON plugs
Power supply: 100-240V/50-60Hz
Power consumption: 155 W heat sink and silent fan.
Finish: Black
Delivered with barndoor, filter frame
Dimensions: 295 x 315 x 377 mm
Weight: 6.2 kg

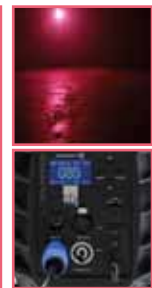

NEW



250W
3200K 15°
50°

BT-THEATRE HD COLOR1
Theater spot 250W RGBAL + Hi-CRI white

Code : B06018



Mains Input: AC 100 - 240V, 50/60Hz
Power consumption: 240 Watts
Power connections: PowerCon input + PowerCon output
DMX connections: 3&5 pin-XLR male / female inputs + outputs
DMX modes: 4 modes (8CH + 10CH + 13CH + 19CH)
Lamp: LED, 200W RGBAL (Red, Green, Blue, Amber, Lime)
White color presets: 1800K 8000K
CRI color rendering: →90 (2700K - 4500K) ~ → 85 (5600K - 8000K)
Beam Angle: electronic zoom 14° - 55°
IP-Rating: IP20
Cooling: heat pipe + forced low speed fan cooling
Weight: 7.6 kg

NEW



BT-THEATRE BARN2
Barndoor for BT-THEATRE HD1

Code : B06019



WW 100W
3200K 10°
50°

BT-THEATRE 100EC Mk2
LED with 10° to 50° manual zoom

Code : B06008



Optics: 1x100W 3200K COB LED
manual zoom: 10° to 50°
7800 lux @ 2m (beam angle: 10°)
Integrated control unit with LCD display with drop-down menu
DMX IN/OUT with 3/5-pin XLR plugs
POWER IN/OUT with powerCON plugs
Power supply: 100-240V/50-60Hz
Power consumption: 125 W
Silent fan (31dB@1m)
Finish: Black
Delivered with barndoor, filter frame
Dimensions: 2788 x 305 x 336 mm
Weight: 6.2 kg



SCENOGRAPHY PROJECTORS



WW 250W 3200K 15° 50°

BT-THEATRE 250EZ
Powerful LED theatre projector with 10° - 50° electronic zoom

Code : B06016



Optics: 1x250W 3200K COB LED
Opening zoom angle: 15° to 50°
Brightness of 1500 to 7735 Lux at 4m
Direct access to the dimmer and zoom
Integrated control unit with LCD display with drop-down menu
DMX IN/OUT with 3/5-pin XLR plugs
POWER IN/OUT with powerCON plugs
Power supply: 100-240V/50-60Hz
Power consumption: 275 W
heat sink and silent fan.
Finish: Black
Delivered with barndoor, filter frame
Dimensions: 458 x 336 x 399 mm
Weight: 8.9 kg



50W COB 20° 34°

SFX-GOR050W

50W LED projector with zoom and rotating gobo

Code : H10848



50W COB LED gobo projector
Brightness of 2840 Lux at 3m at 15°
Opening of 15° to 30°
Manual focus of the lens and opening
Infrared remote control
Rotary gobo holder (outer diam. 25.8 mm, image 19 mm)
4 gobos included
DMX IN/OUT with 3-pin XLR plugs
POWER IN/OUT with Powercon
Silent ventilation
USB port for WTR-DMX (option)
Power supply: 100-240V/50-60Hz
Dimensions: 315 x 175 x 266 mm
Power consumption: 53 W
Finish: black
Weight: 2.8 kg



PROJECTOR CASE 4

Case for 4xBT-Theatre 250EZ & 100 EC Mk2.

Code : B03285



OPTIONAL:
WTR-DMX DONGLE
(code B04645)

The perfect solution for all those who seek wireless DMX

Compatible with:

SFX-GOR050W, SFX-B15QC and SFX-DE50W



R 15W 4° 10° 30° 50°
RGBW

SFX-B15QC

15W 4° DC LED beam projector with remote control

Code : H10831



Optics: 1x15W RGBW COB LED
Opening angle: 4° (10, 30 and 50° frost)
Brightness of 5070 Lux at 3m
Infrared remote control
Ready for a DMX wireless connection with the WTR-DMX option
1-8 channel DMX, fixed colours, Step or Fade programs, Auto mode with sound sensitivity, Slave Mode
LCD display with drop-down menu
DMX IN/OUT with 3-pin XLR plugs
POWER IN/OUT with Powercon
Power supply: 100-240V/50-60Hz
Power consumption: 62 W
Forced fan
Finish: black
Dimensions: 220 x 147 x 191 mm
Weight: 1.8 kg

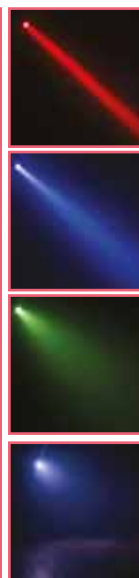

SFX-PC20dimWb

Proj. 20W LED CP Warm White + Amber - Black

Code : H10900



Optical
1 x 20W warm white + amber LED
Colour temperature: 3000°K
CRI 92
Light output of 600 Lux at 3m (39° opening)
Beam angle of 39° or 51°
Functions
Electronic dimmer
Power block or dimmer control possible
Connectors
POWER IN via 2P+E socket
Additional information
Power supply: 100-240V/50-60Hz
Power consumption: 20 W
Cooling system: convection-cooled, without forced ventilation
Finish: Black or white die-cast aluminium body
Dimensions: 186 x 141 x 211 mm
Weight : 2 kg



SFX-PC20dimWw

Proj. 20W LED CP Warm White + Amber-White

Code : H10902



Optical
1 x 20W warm white + amber LED
Colour temperature: 3000°K
CRI 92
Light output of 600 Lux at 3m [39° opening]
Beam angle of 39° or 51°

Functions
Electronic dimmer
Power block or dimmer control possible

Connectors
POWER IN via 2P+E socket

Additional information
Power supply: 100-240V/50-60Hz
Power consumption: 20 W
Cooling system: convection-cooled, without forced ventilation
Finish: Black or white die-cast aluminium body
Dimensions: 186 x 141 x 211 mm
Weight : 2 kg



SFX-PC60QCcb

60W RGBW COB 4-in-1 LED with manual zoom and black finish

Code : H10705



Optics: 1x 60W RGBW COB LED
manual zoom: 20° to 45°
Brightness of 250 to 1870 Lux at 3m
Integrated control unit with LCD display with drop-down menu
DMX IN/OUT with 3-pin XLR plugs
POWER IN with powerCON plugs
Power supply: 100-240V/50-60Hz
Power consumption: 70 W
Dissipation fan
Finish: Black
Delivered with barndoor filter frame
Dimensions: 241 x 196 x 173 mm
Weight: 3.6 kg



SFX-PC60QCw

60W COB 4-in-1 RGBW LED plano-convex projector with manual zoom White finish

Code : H10706



Optics: 1x 60W RGBW COB LED
manual zoom: 20° to 45°
Brightness of 250 to 1870 Lux at 3m
Integrated control unit with LCD display with drop-down menu
DMX IN/OUT with 3-pin XLR plugs
POWER IN with powerCON plugs
Power supply: 100-240V/50-60Hz
Power consumption: 70 W
Dissipation fan
Finish: white
Delivered with barndoor filter frame
Dimensions: 241 x 196 x 173 mm
Weight: 3.6 kg



SFX-PC50Wb

50W COB warm white LED plano-convex projector with manual zoom Black finish

Code : H10703



Optics: 1x50W 3200K COB LED
manual zoom: 20° to 45°
Brightness of 440 to 2200 Lux at 3m
Integrated control unit with LCD display with drop-down menu
DMX IN/OUT with 3-pin XLR plugs
POWER IN with powerCON plugs
Power supply: 100-240V/50-60Hz
Power consumption: 55 W
Dissipation fan
Finish: black
Delivered with barndoor filter frame
Dimensions: 241 x 196 x 173 mm
Weight: 3.6 kg



BT-THEATRE 60FC

60W RGBW COB LED with 10° - 50° manual zoom.

Code : B06015



Optics: 1x 60W RGBW COB LED
manual zoom: 10° to 50°
330 lux at 5m and 10°, 77 lux at 5m and 40°
Integrated control unit with LCD display with drop-down menu
DMX IN/OUT with 3-pin XLR plugs
POWER IN with 1 m cord with plug
Power supply: 100-240V/50-60Hz
Power consumption: 62 W
Dissipation fan
Finish: black
Delivered with barndoor filter frame
Dimensions: 241 x 196 x 173 mm
Weight: 3.6 kg



BT-THEATRE 50WW

LED with 10° - 50° manual zoom. 50W warm white LED

Code : B06013



Optics: 1x50W 3200K COB LED
manual zoom: 10° to 50°
330 lux at 5m and 10°, 77 lux at 5m and 40°
Integrated control unit with LCD display with drop-down menu
DMX IN/OUT with 3-pin XLR plugs
POWER IN with 1 m cord with plug
Power supply: 100-240V/50-60Hz
Power consumption: 55 W
Dissipation fan
Finish: black
Delivered with barndoor filter frame
Dimensions: 241 x 196 x 173 mm
Weight: 3.6 kg

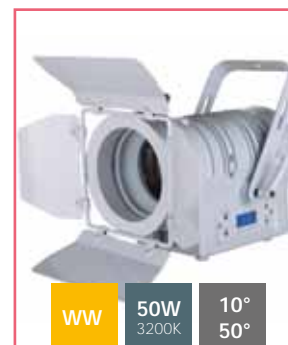

BT-THEATRE 50WW

10° - 50° manual zoom LED. 50W warm white LED

Code : B06014



Optics: 1x50W 3200K COB LED
manual zoom: 10° to 50°
330 lux at 5m and 10°, 77 lux at 5m and 40°
Integrated control unit with LCD display with drop-down menu
DMX IN/OUT with 3-pin XLR plugs
POWER IN with 1 m cord with plug
Power supply: 100-240V/50-60Hz
Power consumption: 55 W
Dissipation fan
Finish: white
Delivered with barndoor filter frame
Dimensions: 241 x 196 x 173 mm
Weight: 3.6 kg



PROJECTOR CASE 5

Flight case for 6 x BT-Theatre 50WW-60FC

Code : B03276



SCENOGRAPHY PROJECTORS



**BT-PROFILE160/
LED ENGINE**
160W COB LED cutout

Code : B06000



High power COB LED profile spot
Optics: 1x160W 3200K COB LED
11566 Lumen
Compatible with ETC "Source Four" optics
Integrated control unit with LCD display
DMX IN/OUT with 3-pin XLR plugs
POWER IN with power cord without plug
Power supply: 100-240V/50-60Hz
Power consumption: 170 W
Extremely silent cooling system using
heat pipe technology
Finish: black
Weight: 6.1 kg
Option:
BT-PROFILE160/OPTIC 15-30
BT-PROFILE160/OPTIC 25-50



**BT-PROFILE160/OP-
TIC 15-30**

Code : B06001



Optical elements with special coating for
clear and well-defined projections
Four contoured, specially coated blades
for minimal reflections
BT-PROFILE160/OPTIC 15-30
15°-30° zoom range
Lockable compartment for the use of
available options:
BT-PROFILE160/GOBO HOLDERIRIS
BT-PROFILE160/IRIS
Using zoom/focus combined with lock-
ing mechanism
BT-PROFILE160/LED ENGINE This is the
active part. Equipped with a 160W COB
LED, it is sold separately.



**BT-PROFILE160/OP-
TIC 25-50**

Code : B06002



Optical elements with special coating for
clear and well-defined projections
Four contoured, specially coated blades
for minimal reflections
BT-PROFILE160/OPTIC 25-50
25°-50° zoom range
Lockable compartment for the use of
available options:
BT-PROFILE160/GOBO HOLDERIRIS
BT-PROFILE160/IRIS
Using zoom/focus combined with lock-
ing mechanism
BT-PROFILE160/LED ENGINE This is the
active part. Equipped with a 160W COB
LED, it is sold separately.



**BT-PROFILE160/
GOBO HOLDER**
GOBO door for BT-PROFILE160/OPTIC

Code : B06003



GOBO holder for BT-PROFILE160/OPTIC
Outer diameter of the gobos: 86mm,
Optical diameter: 64.5mm



BT-PROFILE160/IRIS
Iris for BT-PROFILE160/OPTIC

Code : B06004



Iris for BT-PROFILE160/OPTIC
Opening diameter: adjustable from 5 to
74 mm

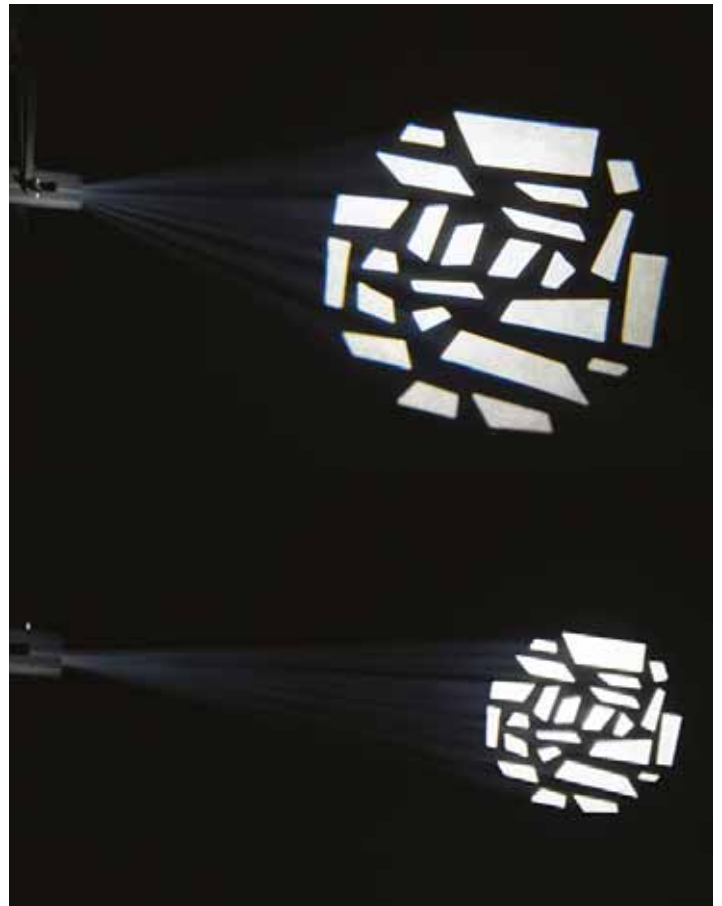

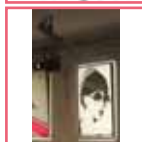

**BT-MINIPROFILE
3200K LED**

Mini LED-profiled projector

Code : B06009



Mini 10W 3200K LED-profile projector
Variation in intensity: using 230V power block or 0-10V voltage.
Power supply: 100-240V/50-60Hz
Dissipation fan
Finish: black
Dimensions: 290 x 107 x 236 mm
Weight: 1.25 kg

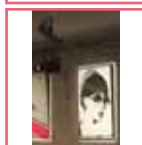

**BT-MINIPROFILE
OPTIC 19deg**

Optional lens 19°

Code : B06010

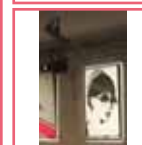

**BT-MINIPROFILE
OPTIC 26deg**

Optional lens 26°

Code : B06011

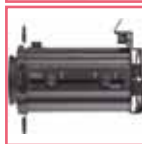

**BT-MINIPROFILE
OPTIC ZOOM**

19°-36° zoom

Code : B06017



19°-36° optional zoom for BT-MINI-PROFILE.



SFX-DE40W

40W white LED profile projector with gobo holder

Code : H10700



40W 3200K COB LED profile spot
Brightness of 1150 Lux at 3m
Opening of 19°
Beam modulation blades
Electronic dimmer
Manual lens focusing
Gobo holder (outer diameter 34mm, image 24mm) 2 gobos included
POWER IN with power cord with plug
Convection fan
Power supply: 100-240V/50-60Hz
Dimensions: 273 x 111 x 100 mm
Power consumption: 40 W
Finish: black
Weight: 1.2 kg

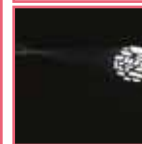
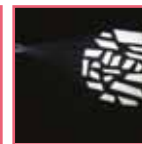

SFX-DE50W

50W DMX LED profile with gobo holder and 10-30° zoom

Code : H10836



50W COB LED profile spot
Brightness of 2840 Lux at 3m at 15°
Opening of 15° to 30°
Beam modulation blades
Manual focus of the lens and opening
Infrared remote control
Gobo holder (outer diam. 25.8mm, image 19mm), 4 gobos included
DMX IN / OUT with 3-pin plugs
POWER IN / OUT with Powercon
Silent ventilation
USB port for WTR-DMX (option)
Power supply: 100-240V/50-60Hz
Dimensions: 500 x 150 x 100 mm
Power consumption: 53 W
Finish: black
Weight: 3 kg

SCENOGRAPHY PROJECTORS

BT-NONABEAM

Exclusive effect for
the show



- ✓ Design created by service providers for service providers
- ✓ Light power in a compact format
- ✓ Rendering that surpasses traditional lamps
- ✓ The Glow effect for smooth transitions



**BT-NONABEAM -
BQ1 (FRANCE BE CH)**
9x60W WW/CW

Code : B05513



**BT-NONABEAM -
BQ2 (EXPORT)**
9x60W WW/CW beam/ RGB

Code : B05521



**CASE FOR
4x BT-NONABEAM**
Flight case pour 4 x BT-Nonabeam

Code : B03284



**BT-NONABEAM set 9
louvers GOLD**

Code : B05514



Mains supply input: 100 to 240 V AC,
50/60 Hz
Electrical connections: Neutrik® Pow-
erCON TRUE1
Power consumption (full speed): 730 W
Power factor: 0.95
Protection class: 1
Protection class: IP20
Fuse: 250 V 6 A thermal fuse
DMX connections: 3 and 5 pin XLR and
male/female XLR connections
Number of DMX channels used: 13 + 29
+ 45 channels
Beam lamps: 9 x LED WHITE, 60 W (30W
3000K / IRC: 91 + 30W 6000K)
Lamps for glow effect: 72 x RGB LED 1 W
LED refresh rate: 1.2 kHz
Beam angle: 4° to 4.5°
Ambient temperature: 40 ° C
Dimensions (W x H x D): 580 x 223 x
142 mm
Weight: 15 kg (16 kg with hook)

Mains supply input: 100 to 240 V AC,
50/60 Hz
Electrical connections: Neutrik® Pow-
erCON TRUE1
Power consumption (full speed): 730 W
Power factor: 0.95
Protection class: 1
Protection class: IP20
Fuse: 250 V 6 A thermal fuse
DMX connections: 3 and 5 pin XLR and
male/female XLR connections
Number of DMX channels used: 13 + 29
+ 45 channels
Beam lamps: 9 x LED WHITE, 60 W (30W
3000K / IRC: 91 + 30W 6000K)
Lamps for glow effect: 72 x RGB LED 1 W
LED refresh rate: 1.2 kHz
Beam angle: 4° to 4.5°
Ambient temperature: 40 ° C
Dimensions (W x H x D): 580 x 223 x
142 mm
Weight: 15 kg (16 kg with hook)



**PREMIUM CASE FOR
4x BT-NONABEAM**

Code : B03286



Crédit : Frank Lambrechts
Band : Racoön



FLAT PROJECTORS

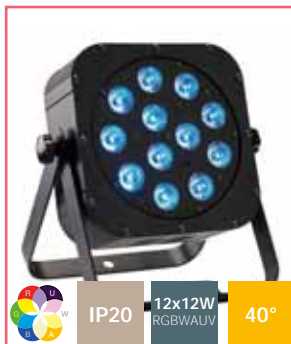

IP20
 12x12W RGBWAUV
 40°

irLDFLAT
12x12SIXb
 12x12W six-colour LEDs

Code : H10143

Contest

12x12W six-colour RGBWA + UV LEDs
 Beam opening: 40°
 Light intensity: 1400 Lux at 3 m
 Infrared remote control
 Digital display with drop-down menu
 Input and output on IEC plugs
 Modes of operation:
 2-9 channel DMX, fixed colours, Step or Fade programs, Auto mode with sound sensitivity, Slave Mode, Editing and playback of a 20-step program
 Power consumption: 160 W
 Power supply: AC 100/240V - 50/60Hz
 DMX input and output
 Dimensions: 275 x 310 x 110 mm
 Net weight: 3.4 kg



IP20
 7x12W RGBWAUV
 30°

PLANO LED 6in1
 7x12W RGBWA + UV LEDs

Code : B04961

JBSYSTEMS

7x12W six-colour RGBWA + UV LEDs
 Beam opening: 30°
 Infrared remote control
 Ready for a DMX wireless connection with the WTR-DMX option
 Digital display with drop-down menu
 Input and output on IEC plugs
 Modes of operation:
 Standalone, Master/slave mode, DMX mode, usable with LEDCON-XL controller
 DMX input and output
 Power consumption: 50 W
 Power supply: AC 100/240V - 50/60Hz
 Dimensions: 210 x 130 x 230 mm
 Net weight: 2.83 kg

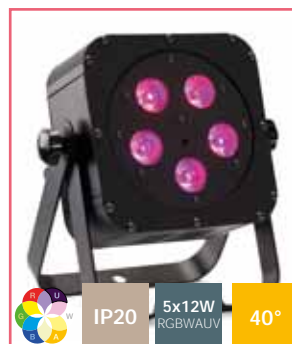

IP20
 5x12W RGBWAUV
 40°

irLEDFLAT-5x12SIXb
 Compact projector with six-colour LEDs, 5x12W LEDs

Code : H10142

Contest

5x12W six-colour RGBWA + UV LEDs
 Beam opening: 40°
 Light intensity: 580 Lux at 3 m
 Infrared remote control
 Digital display with drop-down menu
 Input and output on IEC plugs
 Modes of operation:
 2-9 channel DMX, fixed colours, Step or Fade programs, Auto mode with sound sensitivity, Slave Mode, Editing and playback of a 20-step program
 Power consumption: 80 W
 Power supply: AC 100/240V - 50/60Hz
 DMX input and output
 Dimensions: 240 x 265 x 110 mm
 Net weight: 2.8 kg



IP20
 5x12W RGBWAUV
 40°
 WiFi

irLDFLAT
5x12IfXb-Air
 5 DMX six-colour wireless LEDs

Code : H10525

Contest

5x12W six-colour RGBWA + UV LEDs
 Beam opening: 40°
 Light intensity: 580 Lux at 3 m
 Wireless airDMX embedded transmitter and receiver. 2.4-GHz frequency band
 Compatible with AirBox-ER1 housing
 Infrared remote control
 Digital display with drop-down menu
 Input and output on IEC plugs
 Modes of operation:
 2-9 channel DMX, fixed colours, Step or Fade programs, Auto mode with sound sensitivity, Slave Mode, Editing and playback of a 20-step program
 Power consumption: 80 W
 Power supply: AC 100/240V - 50/60Hz
 DMX input and output
 Dimensions: 240 x 265 x 110 mm
 Net weight: 2.8 kg



IP20
 7x8W RGBW
 30°

LED PLANO 7FC-BLACK
 7x8W RGBW LEDs

Code : B04958

JBSYSTEMS

7x8W RGBW LEDs
 Beam opening: 30°
 Infrared remote control
 Ready for a DMX wireless connection with the WTR-DMX option
 Digital display with drop-down menu
 Input and output on IEC plugs
 Modes of operation:
 Standalone, Master/slave mode, DMX mode, usable with LEDCON-02 or LEDCON-XL controllers
 DMX input and output
 Finish: black
 Power consumption: 38 W
 Power supply: AC 100/240V - 50/60Hz
 Dimensions: 210 x 120 x 220 mm
 Net weight: 2.35 kg



IP20
 7x8W RGBW
 30°

LED PLANO 7FC-WHITE
 7x8W RGBW LEDs

Code : B04959

JBSYSTEMS

7x8W RGBW LEDs
 Beam opening: 30°
 Infrared remote control
 Ready for a DMX wireless connection with the WTR-DMX option
 Digital display with drop-down menu
 Input and output on IEC plugs
 Modes of operation:
 Standalone, Master/slave mode, DMX mode, usable with LEDCON-02 or LEDCON-XL controllers
 DMX input and output
 Finish: white
 Power consumption: 38 W
 Power supply: AC 100/240V - 50/60Hz
 Dimensions: 210 x 120 x 220 mm
 Net weight: 2.35 kg





irLEDFLAT
5x5QCb 10°-Air
 5 10° 4-colour LEDs with wireless DMX

Code : H10527



5x5W RGBW LEDs
 Beam opening: 10°
 Light intensity: 640 Lux at 3 m
 Wireless airDMX embedded transmitter and receiver. 2.4-GHz frequency band
 Compatible with AirBox-ER1
 Infrared remote control
 Digital display with drop-down menu
 Input and output on IEC plugs
 Modes of operation:
 2-7 channel DMX, Fixed colours, Step or Fade programs, Auto mode with sound sensitivity, Slave Mode, Editing and playback of a 20-step program
 Power consumption: 30 W
 Power supply: AC 100/240V - 50/60Hz
 DMX input and output
 Dimensions: 240 x 265 x 110 mm
 Net weight: 2.8 kg



irLEDFLAT-5x5QCb-Air
 5x5W RGBW wireless DMX LEDs

Code : H10524



5x5W RGBW LEDs
 Beam opening: 40°
 Light intensity: 640 Lux at 3 m
 Wireless airDMX embedded transmitter and receiver. 2.4-GHz frequency band
 Compatible with AirBox-ER1 housing
 Infrared remote control
 Digital display with drop-down menu
 Input and output on IEC plugs
 Modes of operation:
 2-7 channel DMX, Fixed colours, Step or Fade programs, Auto mode with sound sensitivity, Slave Mode, Editing and playback of a 20-step program
 Power consumption: 30 W
 Power supply: AC 100/240V - 50/60Hz
 DMX input and output
 Dimensions: 240 x 265 x 110 mm
 Net weight: 2.8 kg



irLEDFLAT-5x5QCb 25°
 Compact projector with 5W RGBW LEDs Black finish - infrared remote control - 25°

Code : H9973



5x5W RGBW LEDs
 Beam opening: 25°
 Light intensity: 640 Lux at 3 m
 Infrared remote control
 Digital display with drop-down menu
 Input and output on IEC plugs
 Modes of operation:
 2-7 channel DMX, Fixed colours, Step or Fade programs, Auto mode with sound sensitivity, Slave mode
 Power consumption: 30 W
 Power supply: AC 100/240V - 50/60Hz
 DMX input and output
 Dimensions: 240 x 265 x 110 mm
 Net weight: 2.8 kg



RAVE SPOT
 3 effects in a single device. Wireless DMX

Code : B06201



3 effects in a single device!
 9 x4W RGB UV LEDs
 1 central 30W RGB COB LED.
 Strobe LED: 21x0.5 W white LEDs.
 Infrared remote control
 Ready for a DMX wireless connection with the WTR-DMX option
 Digital display with drop-down menu
 Input and output on IEC plugs
 Modes of operation: Standalone, Master/slave mode, 1-22 channel DMX mode
 DMX input and output
 Power consumption: 78 W
 Power supply: AC 100/240V - 50/60Hz
 Dimensions: 280 x 275 x 76 mm
 Net weight: 1.81 kg

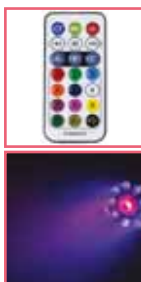

PARTY SPOT
 7x8W RGBW compact LEDs

Code : B04189



7x8W RGBW LEDs
 Digital display with drop-down menu
 Input and output on IEC plugs
 Modes of operation:
 Standalone, Master/slave mode, DMX mode, usable with LEDCON-02 or LED-CON-XL controllers
 DMX input and output
 Power consumption: 38 W
 Power supply: AC 100/240V - 50/60Hz
 Dimensions: 190 x 190 x 140 mm
 Net weight: 1.48 kg



COB SLIM100-RGB
 Energy efficient compact COB LED projector!

Code : B04415



1x100W RGB COB LED
 Beam opening: 15° or 70°
 Light intensity: 1165 Lux at 3 m at 15°
 Ready for a DMX wireless connection with the WTR-DMX option
 Infrared remote control
 Digital display with drop-down menu
 Mains input/output on Powercon plugs
 Modes of operation:
 Standalone, Master/slave, DMX mode, usable with LEDCON-02 MK2 controllers
 Power consumption: 120 W
 Power supply: AC 100/240V - 50/60Hz
 DMX input and output
 Dimensions: 245 x 280 x 140 mm
 Net weight: 3.46 kg



FLAT PROJECTORS



CASE for 4x COB-PLANO

4x COB-PLANO + 1x LEDCON-02 Mk2

Code : B03252



Lightweight and compact case designed for 4x COB-PLANO + LEDCON-02 Mk2
External dimensions: 550 x 315 x 250 mm



COB-PLANO

36W RGB COB, 100°+15°

Code : B04951



1x36W RGB COB LED
Beam opening: 15° or 100°
Infrared remote control
Digital display with drop-down menu
Input and output on IEC plugs
Modes of operation:
Standalone, Master/slave, DMX mode, usable with LEDCON-02 MK2 controllers
Power consumption: 40 W
Power supply: AC 100/240V - 50/60Hz
DMX input and output
Dimensions: 202 x 120 x 224 mm
Net weight: 2.14 kg

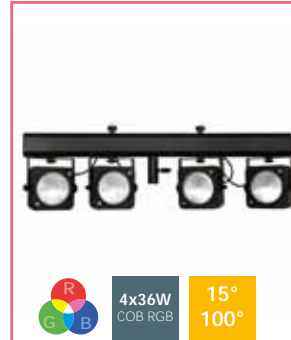

COB-4BAR

4xCOB RGB 36W + IR + Flight case

Code : B04952



4x1 36W RGB COB LED
Beam opening: 15° or 100°
Infrared remote control
Ready for a DMX wireless connection with the WTR-DMX option
Digital display with drop-down menu
Input and output on IEC plugs
Modes of operation:
Standalone, Master/slave, DMX mode, usable with LEDCON-02 MK2 or COB-4BAR FOOTCONTROL controllers
Power consumption: 120 W
Power supply: AC 100/240V - 50/60Hz
DMX input and output
Dimensions: 1000 x 82 x 320mm
Net weight: 11 kg



COB-4BAR FOOT-CONTROL

Pedal assembly for COB-4BAR

Code : B04953

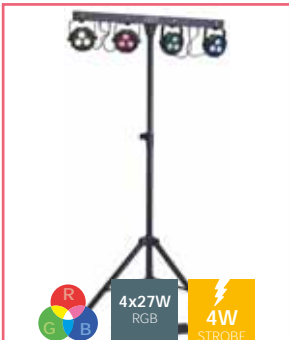

LIVESET

Bar with 4 projectors with 3x9W RGB LEDs and 4x1W white flash LEDs

Code : H10482



12x9W tricolour LEDs
4x1W white LEDs (strobe)
Beam opening: 15°
WiFi pedal assembly
Modes of operation: DMX, Standalone, Musical, Master/slave
1.5m-2m adjustable tripod
Transport bag for light bar+pedal assembly
Carrying case for the tripod supplied
Power supply: 100-240V 50/60Hz
Power consumption: 108W
Dimensions: 1032 x 70 x 235 mm
Net weight: 10.2 kg

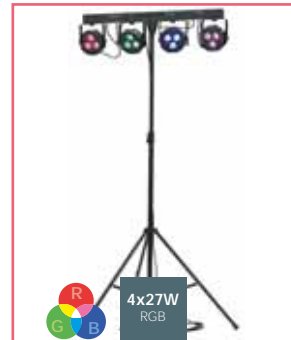

MINISET

Animation light bar with 4 projectors

Code : H10201



12x9W tricolour LEDs
Beam opening: 15°
Pedal assembly for Blackout and programs
Modes of operation: DMX, Standalone, Musical, Master/slave
1.5m-2m adjustable tripod
Transport bag for light bar+pedal assembly
Carrying case for the tripod supplied
Power supply: 100-240V 50/60Hz
Power consumption: 55W
Dimensions: 910 x 242 x 50 mm
Net weight: 10 kg





LIGHT EFFECT CASE 1

Solid flight case for the transport of light effects.

Code : B03216



CASE for COB-4BAR

Lightweight and compact case, specially designed to carry a COB-4BAR

Code : B03249



FLY8-irLEDFLAT

Flight case for 8x FLAT12SIX

Code : H10739



Solid flight case for transport
Divided into 5 compartments:
2x compartments (465x285x260mm)
1x compartment (190x69x260mm)
1x compartment (150x69x260mm)
1x compartment (95x69x260mm)

Lightweight and compact case, specially designed to carry a COB-4BAR
External dimensions: 105 x 34 x 16 cm

irLED64-18x12IfXsb-Air
PAR64 with 18 RGBWAUV LEDs - Wireless DMX

Code : H10532

18x12W six-colour RGBWA + UV LEDs
Beam opening: 40°
Light intensity: 3350 Lux at 3 m
Wireless airDMX embedded transmitter and receiver. 2.4-GHz frequency band
Compatible with AirBox-ER1
Infrared remote control
Digital display with drop-down menu
Input and output on IEC plugs
Modes of operation:
2-9 channel DMX, Fixed colours, Step or Fade programs, Auto mode with sound sensitivity, Slave Mode, Editing and playback of a 20-step program
Power consumption: 240 W
Power supply: AC 100/240V - 50/60Hz
DMX input and output
Black aluminium housing
Dimensions: 340 x 270 x 220 mm
Net weight: 5.4 kg

irLED64-18x12SIXsb
PAR64 with RGBWAUV LEDs - With infrared remote control

Code : H10138

18x12W six-colour RGBWA + UV LEDs
Beam opening: 40°
Light intensity: 3350 Lux at 3 m
Infrared remote control
Digital display with drop-down menu
Input and output on IEC plugs
Modes of operation:
2-9 channel DMX, Fixed colours, Step or Fade programs, Auto mode with sound sensitivity, Slave Mode, Editing and playback of a 20-step program
Power consumption: 240 W
Power supply: AC 100/240V - 50/60Hz
DMX input and output
Black aluminium housing
Dimensions: 340 x 270 x 220 mm
Net weight: 5.4 kg

irLED64-18x12SIXss
PAR64 with RGBWAUV LEDs - With infrared remote control - Aluminium

Code : H10137

18x12W six-colour RGBWA + UV LEDs
Beam opening: 40°
Light intensity: 3350 Lux at 3 m
Infrared remote control
Digital display with drop-down menu
Input and output on IEC plugs
Modes of operation:
2-9 channel DMX, Fixed colours, Step or Fade programs, Auto mode with sound sensitivity, Slave Mode, Editing and playback of a 20-step program
Power consumption: 240 W
Power supply: AC 100/240V - 50/60Hz
DMX input and output
Silver aluminium housing
Dimensions: 340 x 270 x 220 mm
Net weight: 5.4 kg

PAR PROJECTORS



irLED64-18x10FIVEsb
PAR64 with 18x10W 5-colour LEDs
Black finish

Code : H10072



18x10W RGB White + Amber LEDs
Beam opening: 40°
Light intensity: 2150 Lux at 3 m
Infrared remote control
Digital display with drop-down menu
Input and output on IEC plugs
Modes of operation:
2-8 channel DMX, Fixed colours, Step or Fade programs, Auto mode with sound sensitivity, Slave mode, Editing and playback of a 20-step program
Power consumption: 165 W
Power supply: AC 100/240V - 50/60Hz
DMX input and output
Black aluminium housing
Dimensions: 340 x 270 x 220 mm
Net weight: 4.6 kg





irLED64-18x10FIVEss
PAR64 with 18x10W 5-colour LEDs -
Aluminium finish

Code : H10073

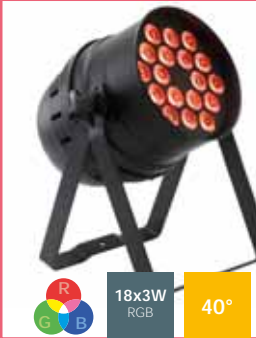

18x10W RGB White + Amber LEDs
Beam opening: 40°
Light intensity: 2150 Lux at 3 m
Infrared remote control
Digital display with drop-down menu
Input and output on IEC plugs
Modes of operation:
2-8 channel DMX, Fixed colours, Step or Fade programs, Auto mode with sound sensitivity, Slave mode, Editing and playback of a 20-step program
Power consumption: 165 W
Power supply: AC 100/240V - 50/60Hz
DMX input and output
Silver aluminium housing
Dimensions: 340 x 270 x 220 mm
Net weight: 4.6 kg





irLED64-18x3TCsb
PAR64 with 18x3W TRI LEDs Black finish

Code : H9876

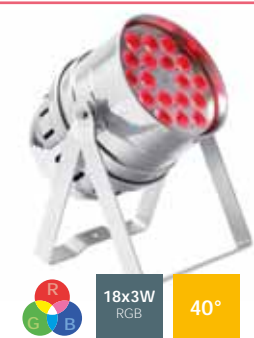

18x3W RGB LEDs
Beam opening: 40°
Light intensity: 1150 Lux at 3 m
Infrared remote control
Digital display with drop-down menu
Input and output on IEC plugs
Modes of operation:
2-6 channel DMX, Fixed colours, Step or Fade programs, Auto mode with sound sensitivity, Slave mode,
Power consumption: 60 W
Power supply: AC 100/240V - 50/60Hz
DMX input and output
Black aluminium housing
Dimensions: 340 x 270 x 220 mm
Net weight: 4.3 kg

irLED64-18x3TCss
PAR64 with 18x3W TRI LEDs Aluminium finish

Code : H9875



18x3W RGB LEDs
Beam opening: 40°
Light intensity: 1150 Lux at 3 m
Infrared remote control
Digital display with drop-down menu
Input and output on IEC plugs
Modes of operation:
2-6 channel DMX, Fixed colours, Step or Fade programs, Auto mode with sound sensitivity, Slave mode,
Power consumption: 60 W
Power supply: AC 100/240V - 50/60Hz
DMX input and output
Silver aluminium housing
Dimensions: 340 x 270 x 220 mm
Net weight: 4.3 kg





FLY-irLED64x6
Flight case for 6 PAR64

Code : H10338

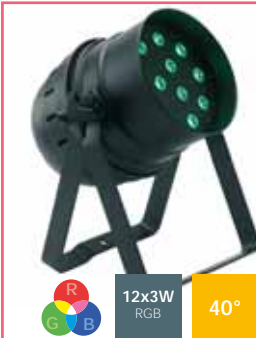

External dimensions - L x W x H:
850 x 580 x 585 mm
Compartment dimensions:
260 x 260 mm Depth: 440 mm
Hood thickness: 65 mm



irLED56-12x3TCsb
PAR56 with 12x3W TRI LEDs - Black finish

Code : H9872



12x3W RGB LEDs
Beam opening: 40°
Light intensity: 1030 Lux at 3 m
Infrared remote control
Digital display with drop-down menu
Input and output on IEC plugs
Modes of operation:
2-6 channel DMX, Fixed colours, Step or Fade programs, Auto mode with sound sensitivity, Slave mode,
Power consumption: 40 W
Power supply: AC 100/240V - 50/60Hz
DMX input and output
Black aluminium housing
Dimensions: 360 x 270 x 170 mm
Net weight: 2.8 kg





12x3W RGB 40°

irLED56-12x3TCss
PAR56 projector with 12 3W TRI LEDs Aluminium finish - Infrared remote control

Code : H9871



12x3W RGB LEDs
Beam opening: 40°
Light intensity: 1030 Lux at 3 m
Infrared remote control
Digital display with drop-down menu
Input and output on IEC plugs
Modes of operation:
2-6 channel DMX, Fixed colours, Step or Fade programs, Auto mode with sound sensitivity, Slave mode,
Power consumption: 40 W
Power supply: AC 100/240V - 50/60Hz
DMX input and output
Silver aluminium housing
Dimensions: 360 x 270 x 170 mm
Net weight: 2.8 kg



12x12W RGBWAUV 15°

BT-STAGEPAR 6in1
12x12W RGBWA projector + UV - 15°

Code : B04377



12x12W six-colour RGBWA + UV LEDs
Beam opening: 25°
Digital display with drop-down menu
Mains output on IEC plugs
Modes of operation:
1-9 channel DMX, Fixed colours, Step or Fade programs, Auto mode with sound sensitivity, Slave mode,
Mode: Halogen lamp or Diode
White balance
Remote setup: RDM
Power supply: AC 100/240V - 50/60Hz
DMX input and output
finish: black
Dimensions: 300 x 275 x 300 mm
Net weight: 3.5 kg



CW 100W 5600K 60°

SILVER COB PAR56-100CW
LED projector with parabolic reflector

Code : B04408



Optics: 1x100W 5600K COB LED
Opening angle: 60°
Digital display with drop-down menu
Mains output on IEC plugs
Modes of operation:
1-2 channel DMX, Fixed colours, Step or Fade programs, Auto mode with sound sensitivity, Slave mode,
Mode: Halogen lamp or Diode
Power supply: 100-240V/50-60Hz
DMX input and output
Finish: silver
Delivered with 25° lens, filter door
Dimensions: 417 x 286 x 260 mm
Weight: 2.8 kg



WW 100W 3200K 60°

BLACK COB PAR56-100WW
LED projector with parabolic reflector

Code : B04411



Optics: 1x100W 3200K COB LED
Opening angle: 60°
Digital display with drop-down menu
Mains output on IEC plugs
Modes of operation:
1-2 channel DMX, Fixed colours, Step or Fade programs, Auto mode with sound sensitivity, Slave mode,
Mode: Halogen lamp or Diode
Power supply: 100-240V/50-60Hz
DMX input and output
Finish: black
Delivered with 25° lens, filter door
Dimensions: 417 x 286 x 260 mm
Weight: 2.8 kg



WW 100W 3200K 60°

SILVER COB PAR56-100WW
LED projector with parabolic reflector

Code : B04410



Optics: 1x100W 3200K COB LED
Opening angle: 60°
Digital display with drop-down menu
Mains output on IEC plugs
Modes of operation:
1-2 channel DMX, Fixed colours, Step or Fade programs, Auto mode with sound sensitivity, Slave mode,
Mode: Halogen lamp or Diode
Power supply: 100-240V/50-60Hz
DMX input and output
Finish: silver
Delivered with 25° lens, filter door
Dimensions: 417 x 286 x 260 mm
Weight: 2.8 kg



RGB 100W COB RGB 50°

PAR56-RGB COB
100xW RGB COB LED

Code : B04403



Optics: 1x100W RGB COB LED
Opening angle: 50°
Digital display with drop-down menu
Mains output on IEC plugs
Modes of operation:
3-, 4- and 5-channel DMX, Fixed colours, Step or Fade programs, Auto mode with sound sensitivity, Slave mode,
Power supply: 100-240V/50-60Hz
DMX input and output
Finish: black
Delivered with 25° lens, filter door
Dimensions: 417 x 286 x 260 mm
Weight: 2.8 kg



PAR PROJECTORS



COB BARNDOOR/Black
Barndoor for COB PAR56

Code : B04413



COB BARNDOOR/Silver
Barndoor for COB PAR56

Code : B04414



PROJECTOR CASE
Flight case for carrying 4 projectors

Code : B03253



RETRO-PAR20 RGBW
15W RGBW RETRO-PAR20 LED IR Remote Control

Code : B05129



For:
BRITEQ COB-PAR
BRITEQ BT-Stagepar 6in1
BRITEQ BT-Theatre 1EZ
BRITEQ BT-Theatre 100EC

RETRO-PAR20 LED projector
1x15W RVBW LED.
Opening: 10°
Infrared remote control IR-3
16 fixed colours (with dimming).
"Fade", "soft transition" and "flash"
colour interlacing (with speed control).
Strobe function (with speed control).
Easy to use sound control mode.
Power supply: 100-240V/50-60Hz
finish: black
Dimensions: 198 x 112 x 100 mm
Weight: 0.65 kg



PIN15QC
4° beam projector with 15W 4-colour LEDs

Code : H10595



PIN15W
4° beam projector with 15W warm white LED

Code : H10709

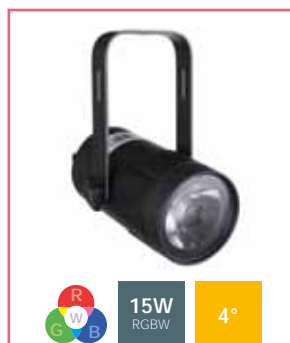

BEAMSPOT1-DMX FC
15W RGBW projector, equipped with a very narrow 4° lens

Code : B04957



1x15W RGBW LED
Openings: 4° | 10° | 45°
Power consumption: 17 W
Power supply: AC100V-240V. 60Hz-50Hz
IEC IN/OUT
DMX 3-pin IN/OUT
Automatic or music programs DMX
Control: 1,4,7,12 channels
Infrared remote control
Dimensions: 135 x 203 x 172 mm
Net weight: 1.4 kgs

1x15W warm white LED
Openings: 4° | 10° | 45°
Power consumption: 17 W
Power supply: AC100V-240V. 60Hz-50Hz
IEC IN/OUT
DMX 3-pin IN/OUT
Automatic or music programs DMX
Control: 1, 2 channels
Infrared remote control
Dimensions: 135 x 203 x 172 mm
Net weight: 1.4 kgs

1x15W RGBW LED
Openings: 4° | 10° | 45°
Power consumption: 17 W
Power supply: AC100V-240V. 60Hz-50Hz
Powercon IN/OUT
DMX 3-pin IN/OUT
DMX control: 4-7 channels
Dimensions: 125 x 196 x 172 mm
Net weight: 1.23 kgs







NW 15W 4°

BEAMSPOT1-DMX NW
15W WHITE projector equipped with a very narrow 4° lens.

Code : B04956



1x15W natural white 4500K LED
 Openings: 4° | 10° | 45°
 Power consumption: 17 W
 Power supply: AC100V-240V. 60Hz-50Hz
 Powercon IN/OUT
 DMX 3-pin IN/OUT
 DMX control: 1-2 channels
 Dimensions: 125 x 196 x 172 mm
 Net weight: 1.23 kgs



WW 15W 4°

BEAMSPOT1-DMX WW
15W WARM WHITE 4° lens

Code : B04960



1x15W warm white 3200K LED
 Openings: 4° | 10° | 45°
 Power consumption: 17 W
 Power supply: AC100V-240V. 60Hz-50Hz
 Powercon IN/OUT
 DMX 3-pin IN/OUT
 DMX control: 1-2 channels
 Dimensions: 125 x 196 x 172 mm
 Net weight: 1.23 kgs



NW 15W 4°

BEAMSPOT1-TRIAC NW
15W WHITE projector

Code : B04955



1x15W natural white 4500K LED
 Openings: 4° | 10° | 45°
 NO DMX: can be controlled using a traditional triac dimmer / triac light modulator or the dimmer located on the rear panel.
 Power consumption: 17 W
 Power supply: AC100V-240V. 60Hz-50Hz
 Fixed power cord with standard power outlet
 Dimensions: 125 x 196 x 172 mm
 Net weight: 1.23 kgs

WW 15W 4°

BEAMSPOT1-TRIAC WW
This 15W PINSPOT

Code : B04954



1x15W warm white 3200K LED
 Openings: 4° | 10° | 45°
 NO DMX: can be controlled using a traditional triac dimmer / triac light modulator or the dimmer located on the rear panel.
 Power consumption: 17 W
 Power supply: AC100V-240V. 60Hz-50Hz
 Fixed power cord with standard power outlet
 Dimensions: 125 x 196 x 172 mm
 Net weight: 1.23 kgs





LED PINSPOT
3W white LED projector, lenses incl. 6° + 11°

Code : B04918



1x3W LED
 Openings: 6° | 11°
 Power consumption: 8 W
 Power supply: AC100V-240V. 60Hz-50Hz
 Fixed power cord with standard power outlet
 Dimensions: 104 x 78 x 55 mm
 Net weight: 0.44 kgs



PAR46/black
PAR 46 with black E27 socket.

Code : B02066



Ideal for stores and showrooms!
 Power cord included
 E27 socket for PAR 38 lamp (lamp not included)
 Filter holder included
 Finish: black
 Total length without holder: 31cm barn-door option available

PAR PROJECTORS



PAR46/silver

PAR 46 with chrome-coloured E27 socket.

Code : B02053



PAR46-BARN/black

Barndoor for PAR46

Code : B02079



PAR46-BARN/silver

Barndoor for PAR46

Code : B02080



PINSPO/Black

Projector for PAR36 lamp

Code : B02034



Ideal for stores and showrooms!
Power cord included
E27 socket for PAR 38 lamp (lamp not included)
Filter holder included
Finish: silver
Total length without holder: 31cm barn-door option available

Projector for 30W/6V PAR 36 lamp
Equipped with a transformer, fuse holder and clips to fix the lamp
Finish: black
Without lamp



PAR30/black

Projector for PAR30 or PAR20 lamp

Code : B02088



PAR30/silver

Projector for PAR30 or PAR20 lamp

Code : B02087



PAR30-BARN/black

Barndoor for PAR30

Code : B02077



PAR30-BARN/silver

Barndoor for PAR30

Code : B02078



Projector for Par 30 or Par 20 lamp
Compatible with halogen lamps and E27 socket LED lamps
Power supply 230V AC
Finish: black
Total length without holder: 22 cm
Without lamp

Projector for Par 30 or Par 20 lamp
Compatible with halogen lamps and E27 socket LED lamps
Power supply 230V AC
Finish: silver
Total length without holder: 22 cm
Without lamp

PAR PROJECTORS



PAR20/black
Projector for PAR20 lamp

Code : B02086



Projector for PAR20 lamp
Finish: black
Total length without holder: 17cm
Without lamp



PAR20/silver
Projector for PAR20 lamp

Code : B02085



Projector for PAR20 lamp
Finish: silver
Total length without holder: 17cm
Without lamp



PAR20-BARN/black
Barndoor for PAR20

Code : B02075



PAR20-BARN/silver
Barndoor for PAR20

Code : B02076



PAR16/black GU10 socket
Projector for PAR16 lamp

Code : B02061



GU10 socket for the use of: LED lamps
(GU10) Halogen lamp (35W or 50W/230V)
Finish: black
No transformer necessary
Total length without holder: 14.5cm
Without lamp



PAR16/Silver GU10 socket
Projector for PAR16 lamp

Code : B02055



GU10 socket for the use of: LED lamps
(GU10) Halogen lamp (35W or 50W/230V)
Finish: silver
No transformer necessary
Total length without holder: 14.5cm
Without lamp



PAR16-BARN/black
Barndoor for PAR16

Code : B02073



PAR16-BARN/silver
Barndoor for PAR16

Code : B02074



TF36
Transformer for PAR36 lamp (30W/6V)

Code : B02045



PANELS, BLINDERS AND FLOOD



PIX44

16 30W TRI COB LED Flood Projector With LCD display

Code : H10016



16 COB LEDs
30W tri-colour LEDs
Beam opening: 60°
DMX 3- and 5-pin XLR input and output
Power input and output on PowerCON® (maximum 5 projectors connected to each other)
Power consumption: 500W
Power supply: AC 100/240V - 50/60Hz
Cooling by temperature regulated ventilation
Dimensions: 345 x 345 (365 with the moving head) x 180 mm
Net weight: 8.25 Kg



Powerpixel4-RGB

Bar with 4 30W TRI COB LEDs With LCD display

Code : B04400



4 COB LEDs
30W tri-colour LEDs
Beam opening: 60°
DMX 3- and 5-pin XLR input and output
Power input and output on PowerCON® (maximum 20 projectors connected to each other)
Power consumption: 120 W
Power supply: AC 100/240V - 50/60Hz
Cooling by temperature regulated ventilation
Dimensions: 440 x 150 x 180 mm
Net weight: 5 Kg



Powerpixel8-RGB

Bar with 8 30W TRI COB LEDs With LCD display

Code : B04401



8 COB LEDs
30W tri-colour LEDs
Beam opening: 60°
DMX 3- and 5-pin XLR input and output
Power input and output on PowerCON® (maximum 10 projectors connected to each other)
Power consumption: 240 W
Power supply: AC 100/240V - 50/60Hz
Cooling by temperature regulated ventilation
Dimensions: 880 x 60 x 170 mm
Net weight: 8 Kg



PROJECTOR CASE 2

Flight case for POWERPIXEL8-RGB, POWERPIXEL4-RGB, BEAMBAR10-RGBW, BEAMBAR5-RGBW

Code : B03257



BT-BLINDER2 IP

Ready for everything and in any weather conditions.

- ✓ Robustness and Weather-Resistant
- ✓ Red-Shift effect
- ✓ Professional "line array" rigging



BT-BLINDER2 IP

Code : B05520



Mains power input: 100 to 240 V AC, 50/60 Hz Internal fuse: 250 V AC/T2A
Electrical connections: Neutrik® PowerCON TRUE1 (input/output)
Power consumption (full power): 310 W
Power factor: → 0.95
Series connection: 5 units (at 240 V AC)
Protection class: 1
Protection class: IP65 - outdoor use
DMX connections: 5-pin male/female XLR (modification kit to 3-pin XLR available)
Number of DMX channels used: 4 + 6 + 10 channels
LED : 2 of 135 W (warm white and yellow) Color temperature (CCT) : 1 650 K 3 000 K (AMBER EFFECT effect)
IRC factor: → 97
LED refresh rate: 3.6 kHz
Strobe frequency: 0.5 30 Hz
Ambient temperature: 40 °C
Weight: 8.1 kg (8.8 kg with set of fixing elements)



BT-BLINDER2 IP RIGGING SET

Rigging set for BT-BLINDER2 IP

Code : B05522



CASE FOR 3x BT-BLINDER2 IP

Flightcase for 3 x BT-BLINDER2 IP

Code : B03290





COB Blinder 2x100W

LED BLINDER equipped with two white 100Watt LED projectors

Code : B04402



BEAM MATRIX5x5-RGBW

5x5 MATRIX effect, 25x 15W RGBW 4.5°beams + Artnet

Code : B04416



MATRIX5x5-CASE

Flight case for 6x MATRIX5x5

Code : B04422



LED BLINDER equipped with two white 100Watt 3200k LED projectors
Opening angle: 60°
The two projectors can be controlled independently
DMX mode: 1, 2 or 4 channels
Static mode: Stroboscopic effect dimmer Master/Slave Mode, Variable stroboscopic effect
Halogen (slow) or LED (fast) mode
Dimming 16 bit from 0% to 100%
DMX IN/OUT on XLR 3/5-pin plug
POWER IN/OUT with Powercon
Power: AC 100 - 240V, 50/60Hz
Power consumption: 235W
Dimensions: 440 x 144 x 355 mm
Weight: 4.46 kg

25 15W RGBW LEDs 5x5 Matrix
Lens opening: 4.5°
DMX mode: 4-150 channels
Ethernet input/output: Art-Net support
Internal programs in standalone mode or via DMX, Master/slave mode, static or fade colours, static or sound-triggered chasers.
Halogen (slow) or LED (fast) mode
Balancing of individual whites by Pixel
Four intensity variation curves
DMX IN/OUT on XLR 3/5-pin plug
POWER IN/OUT with Powercon
Power: AC 100 - 240V, 50/60Hz
Power consumption: 415W
Dimensions: 550 x 550 x 120 mm
Weight: 18 kg



PANELS, BLINDERS AND FLOOD



BEAMBAR5-RGBW
LED Narrow Beam Bar, 5x 15W RGBW
Osram + Artnet

Code : B04419



5 15W RGBW Osram LEDs
Lens opening: 4.5°
Frost filter: included
DMX mode: 3-30 channels
Ethernet input/output: Art-Net support
Internal programs in standalone mode or via DMX, Master/slave mode, static or fade colours, static or sound-triggered chasers.
Halogen (slow) or LED (fast) mode
Balancing of individual whites by Pixel
Four intensity variation curves
DMX IN/OUT on XLR 3/5-pin plug
POWER IN/OUT with Powercon
Power: AC 100 - 240V, 50/60Hz
Power consumption: 100W
Dimensions: 440 x 182 x 160 mm
Weight: 6.02 kg



PIX9W33
9 9W TRI LED Flood Projector

Code : H10133



9 9W RGB LEDs
Beam opening: 25°
Digital display with drop-down menu for control
DMX mode: 2-30 channels
Fixed colours, Step or Fade programmes
Auto mode, Audio mode with sound sensitivity, Slave mode
Multi-slave mode to chain patterns across multiple devices
DMX IN/OUT on XLR 3-pin plug
POWER IN/OUT by IEC plug
Power supply: AC 100/240V - 50/60Hz
Power consumption: 110W temperature regulated ventilation
Dimensions: 260 x 260 x 180 mm
Net weight: 4.9 Kg



PIX9W14
Bar with 4 9W TRI LEDs

Code : H10134



4 9W RGB LEDs
Beam opening: 25°
Digital display with drop-down menu for control
DMX mode: 2-15 channels
Fixed colours, Step or Fade programmes
Auto mode, Audio mode with sound sensitivity, Slave mode
Multi-slave mode to chain patterns across multiple devices
DMX IN/OUT on XLR 3-pin plug
POWER IN/OUT by IEC plug
Power supply: AC 100/240V - 50/60Hz
Power consumption: 48W temperature regulated ventilation
Dimensions: 340 x 140 x 140 mm
Net weight: 2.9 Kg



BT-GLOWPANEL BLACK
36 4° lens matrix with RGB effects

Code : B05503



36 3W 2800K LEDs 4° lens
144 SMD 5050 LEDs for RGB (glow) effects
LCD display: drop-down menu for control
5 DMX modes: 4-48 channels
Integral DMX control with different channel modes, from simple 4-channel mode to 48-channel mode for a complete RVB+dimmer control for each pixel and panel.
Automatic mode, Slave mode
DMX IN/OUT on XLR 3-pin plug
POWER IN/OUT with Powercon
Power supply: AC 100/240V - 50/60Hz
Power consumption: 190W
ventilation: natural convection
Dimensions: 500 x 500 x 84 mm
Net weight: 8.5 Kg
Optional suspension bracket:
BT-GLOWPANEL BRACKET



BT-GLOWPANEL BRACKET
Hanger for BT-GLOWPANEL.

Code : B04426



Suspension bracket for mounting BT-GLOWPANEL on a large-matrix structure.



CASE for 6x BT-GLOWPANEL
Flight case for 6x BT-GLOWPANEL

Code : B03269





BT-RETRO

A retro look for a modern scenography
The compact version of the BT-VINTAGE
with the same light quality and Glow
effects.

The design of the projector allows them
to be mechanically combined to form sets
according to your needs

The BT-RETRO has an integrated DMX
control to adjust the drive and RGB effects.
It is prepared for television studios with a
flicker-free LED refresh rate.



BT-RETRO

Projecteur vintage RGB

Code : B05518



BT-RETRO coupling adapter

Adaptateur pour BT-RETRO

Code : B05519



CASE FOR 2xBT-RETRO

Flightcase for 2 x BT-RETRO

Code : B03289



Mains power input: 100 to 240 V AC,
50/60 Hz
Halogen lamp (mains input 110 V AC):
G9,5 - HPL-575W 120 V
Halogen lamp (mains input 230 V AC):
G9,5 - HPL-575W 240 V
Maximum power consumption: 480 W
(halogen (limited to 320 W) + LED (120
W) fully lit)
Fuse: 250 V T 6.3A (20 mm glass)
DMX connections: 3 and 5-pin male/
female XLR XLR connections
Number of DMX channels used: 3
modes (5 + 6 + 7 channels)
RGB LED: 48 RGB units 3,5 W
LED refresh rate: 1,200 Hz
Weight: 8,66 kg
Lamp not supplied



HPL 575-X LL (code B02171)

230V halogen lamp for
BT-RETRO. For a warm and
pleasant light



FLOOD PROJECTORS

This attractive retro-style projector is perfect for many applications.

The combination of its golden reflector and an HPL-575 lamp creates a warm and pleasant light. The high-power RGB LEDs can illuminate the reflector to produce incredible additional effects.

The BT-VINTAGE has an integrated DMX control to adjust the dimmer and RGB effects. It is prepared for TV studios with a flicker-free LED refresh rate.



BT-VINTAGE

Retro-style projector with golden reflector, HPL-575 lamp and RGB LEDs to produce incredible warm colour effects.

Code : B04547



CASE for 2x BT-VINTAGE

Flight case for 2x BT-VINTAGE

Code : B03271



HPL 575-X LL (code B02171)

230V halogen lamp for BT-VINTAGE. For a warm and pleasant light



RGB LEDs (156 x 1W RVB)
Wireless DMX: USB port for WTR-DMX dongle (optional)
PowerCON input and output
XLR 3/5-pin input and output
Power supply: AC 100/240V - 50/60Hz
Power consumption: 980W
Ventilation: natural convection
Dimensions: 696 x 650 x 370 mm
Net weight: 14 Kg
Lamp not supplied

EFFECT PROJECTORS

The BT-LEDROTOR is a 70x70cm high power LED effect fan for TV studios, rental, etc.

Each of the 6 blades is equipped with 5 RGB LED sections that you can control individually.

In addition, a UV LED effect has been added

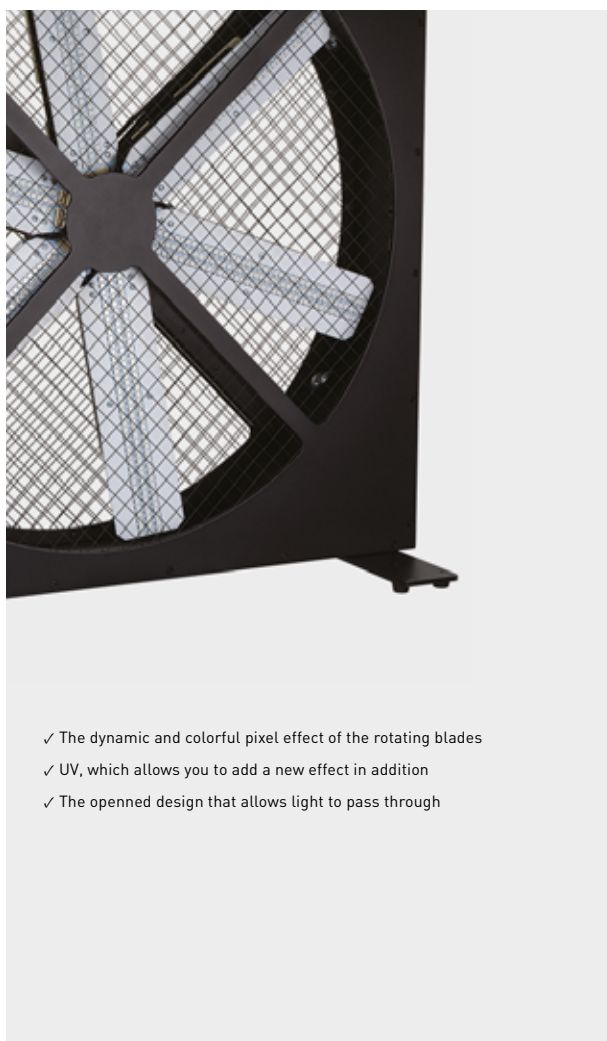
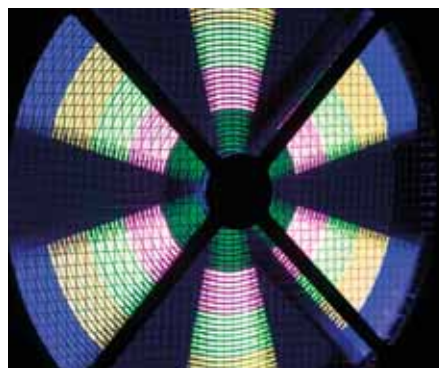
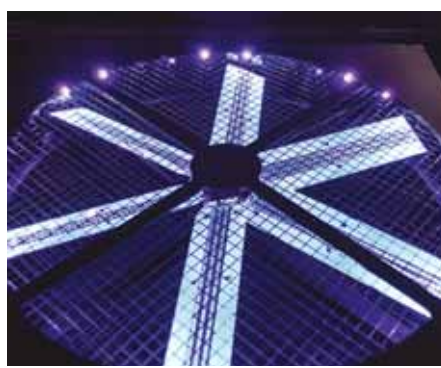

- ✓ The dynamic and colorful pixel effect of the rotating blades
- ✓ UV, which allows you to add a new effect in addition
- ✓ The opened design that allows light to pass through

NEW



UV
fonction

BT-LEDROTOR
DMX controlled RGB+UV LED ROTOR

Code : B05516

BriteQ
LIGHT RESEARCH

NEW



CASE FOR 4xBT-LEDROTOR
Flight case for 4 x BT-Ledrotor

Code : B03283

BriteQ
LIGHT RESEARCH

Mains Input: AC 100V – 240V, 50/60Hz
Power connections: Neutrik® PowerCON
Power consumption (full power): 240 W
Daisy chaining: 9pcs (@ 240Vac)
Power factor: →0.95
Protection class: 1
IP-rating: IP20
Fuse: 250V 3A thermal fuse [5 x 20mm]
DMX connections: 3pin + 5pin XLR male / female
DMX channels used: 5 + 12 + 33 channels
UV LEDs: 32pcs 3W (UV, 405nm)
RGB LEDs : 720pcs 0.2W RGB-leds
LED refresh rate: 0.6 kHz
Ambient temperature: 40°C
Weight: 18kg [20.3kg incl. 2x floor stand]



MOVING HEADS



- OSRAM SIRIUS HRI 280 (7800 K°) lamp
- BEAM: from 2.6° to 11°
- SPOT: from 5.2° to 23°
- 1 wheel with 13 colours
- 14 fixed gobos + open
- 9 replaceable rotating gobos
- 8-facet prism + linear with 6 facets
- Frost | Zoom + Focus



BTX-TITAN

BEAM + SPOT + WASH effects

Code : B04378



CASE FOR 2x BTX-TITAN

Flight case for 2x BTX-TITAN

Code : B03251



OSRAM SIRIUS HRI 280 source
Beam from 2.6° to 11°: 82,650 lux at 20 m
Spot from 5.2° to 23°: 25400 lux at 10 m
2 combinable prisms:
8-facet circular rotating prism
6-facet linear rotating prism
wheel with 9 rotating gobos + open
wheel with 14 fixed gobos + open
wheel with 13 dichroic colours (CTO-CTB)
Frost effect (WASH)
Stroboscopic effects
Motorised Focus + Zoom
Variable dimmer from 0 to 100%
DMX mode: 16, 24 or 25 channels
Drop-down menu display
Amplitude: 540° pan - 270° tilt
Power consumption: 400W
Power supply: AC 100/230V - 50/60Hz
Dimensions: 391x287x583 mm
Net weight: 22 Kg

MOVING HEADS



- 270W CW LED
- Linear zoom from 8 to 45°
- 3-facet prism
- Wheel with 7 rotating gobos + open
- Wheel with 9 colours including 2xCTO 1xCTB, UV + open
- Iris
- Frost
- Focus



- 3-in-1 beam, spot, wash moving head
- Powerful LED source
- 1 6-facet linear rotating prism
- 1 8-facet rotating circular prism
- Linear transition from Beam mode to Spot mode



BTX-SATURN

Moving head with 270 W LED

Code : B04428



MOVING HEAD CASE 3

Flight case for 4x BTX-SATURN

Code : B03273



FUSION180

Beam Spot and Wash moving head with 180W LED

Code : H10661



FLY2Fusion180

Flight case for 2x FUSION180

Code : H10737



270W CW LED source
 Linear zoom from 8 to 45°
 3-colour process with dichroic CMY filters
 3-facet circular rotating prism
 Wheel with 7 rotating gobos + open
 Wheel with 9 fixed gobos + 3 reducers
 Wheel with 9 colours including 2xCTO, 1xCTB, UV + open
 Variable iris
 Frost effect (WASH)
 Stroboscopic effects motorised focus
 Electronic dimmer variable from 0 to 100%
 DMX mode: 25 channels
 Drop-down menu display
 Amplitude: 540° pan - 270° tilt
 Power IN/OUT: Neutrik powerCON® TRUE-1
 DMX IN/OUT: XLR 3+5pin
 Power supply: AC 100/230V - 50/60Hz

180W CW LED source
 Linear zoom from 6 to 21° (Beam to Spot)
 Light power: 33000 lux at 5m (6°)
 8-facet circular rotating prism
 6-facet linear rotating prism
 wheel with 9 rotating gobos + open
 wheel with 12 fixed gobos + 3 reducers
 wheel with 10 dichroic colours + open
 Progressive Frost filter
 Wash function going from 34° to 60°
 Stroboscope from 1 to 25 flashes / second
 motorised focus
 Electronic dimmer variable from 0 to 100%
 DMX mode: 17,19 or 20 channels
 Drop-down menu display
 Amplitude: 540° or 630° pan - 270° tilt
 Power consumption: 305W
 Power supply: AC 100/230V - 50/60Hz
 Dimensions: 369x288x583 mm
 Net weight: 18 Kg



MOVING HEADS



BTX-CIRRUS

The power, the beam angle and perfect pixel effect



NEW



BTX-CIRRUS
Led Moving wash 19x30W FC pixel control
4-60°

Code : B05515



NEW



**MOVING HEAD CASE
4**
Flight case for 2x BTX-CIRRUS

Code : B03288



- LED moving head 19x30 OSRAM LEDs
- 19000 Lux@5m/4°
- Full pixel mapping
- Zoom from 4° to 60°.
- Three-phase motors Moons
- Noiseless operation

Mains Input: AC 100-240V, 50/60Hz
Power consumption: 650W

DMX connections: 3pin & 5pin XLR IN/
OUT

Movement: Pan: 540° Tilt: 210° (+ Pan/
Tilt lock for transport protection)

Beam angle: 4°→60°

DMX channels used: 20-29-48-77-86-96
Channels
Lamp: 19 Osram 30W RGBW LEDs

Weight: 16 kg

MOVING HEADS



BTX-BEAM 5R

Ultra powerful moving head based on the legendary Philips MSD Platinum 5R lamp!

Code : B04353



SWORD5R

BEAM moving head with Philips© MSD PLATINUM 5R lamp

Code : H10409



RAY1R

Beam moving head with HRI 100W OSRAM© Lamp

Code : H10410



BT-TRACKER

Super compact but very powerful moving head SIRIUS HRI-100 lamp from OSRAM!

Code : B04387



Philips MSD Platinum 5R source
Light power: 200000 lux at 10m
Beam opening: 1 to 3.5°
Stroboscopic effects
Motorised focus
Frost filter
8-facet rotating prism wheel with 17 gobos + open wheel with 14 dichroic colours + open wheel with 14 dichroic colours + open
Variable dimmer from 0 to 100%
DMX mode: 19 channels
Drop-down menu display to assign and select different modes
Amplitude: 540° pan - 270° tilt
Power consumption: 290 W maximum
Power supply: AC 100/230V - 50/60Hz
Dimensions: 415 x 343 x 487 mm
Net weight: 20 Kg

Philips MSD Platinum 5R source
Light power: 770000 lux at 5m
Beam opening: 3.5°
Strobe, pulse effect and random strobe
Motorised focus
Frost filter
8-facet rotating prism wheel with 17 gobos + open wheel with 14 dichroic colours + open wheel with 14 dichroic colours + open
Variable dimmer from 0 to 100%
DMX mode: 1, 12 and 16 channels
Synchronised shows (internal microphone)
Master / Slave mode
Drop-down menu display to assign and select different modes
Amplitude: 540° pan - 270° tilt
Power consumption: 270 W maximum
Power supply: AC 100/230V - 50/60Hz
Dimensions: 500 x 394 x 525 mm
Net weight: 18 Kg

Osram SIRIUS HRI 100W source
Light power: 307200 lux at 5m
Beam opening: 3°
Strobe, pulse effect and random strobe
8-facet rotating prism wheel with 15 gobos + open wheel with 14 dichroic colours + open
Variable dimmer from 0 to 100%
DMX mode: 1.10 and 14 channels
Synchronised shows (internal microphone)
Master / Slave mode
Drop-down menu display to assign and select different modes
Amplitude: 540° pan - 270° tilt
Power consumption: 194.5 W maximum
Power supply: AC 100/230V - 50/60Hz
Dimensions: 279 x 225 x 387 mm
Net weight: 9.2 Kg

Osram SIRIUS HRI 100W source
Light power: 307200 lux at 5m
Beam opening: 3°
Strobe, pulse effect and random strobe
8-facet rotating prism wheel with 10 gobos + 4 reducers + open wheel with 14 dichroic colours + open
Variable dimmer from 0 to 100%
DMX mode: 5 and 12 channels
Synchronised shows (internal microphone)
Master / Slave mode
Drop-down menu display to assign and select different modes
Amplitude: 540° pan - 270° tilt
Power consumption: 194.5 W maximum
Power supply: AC 100/230V - 50/60Hz
Dimensions: 279 x 225 x 401 mm
Net weight: 9.2 Kg



FLY-RAY1R-HE-Z0120Zx4

Flight case for 4 RAY1R or 4 HEZ0120Z

Code : H10610



CASE for 4x BT-TRACKER

Flight case for 4x BT-TRACKER.

Code : B03264



FLY2CLUB-S1

Flight case for Typhoon/Thunder/Cyclone/Wave

Code : H10247



CASE FOR 2x BTX-BEAM 5R

Flight case for 2 x Briteq BTX-BEAM 5R

Code : B03239



MOVING HEADS



BTX-HAWK

Very bright moving head controlled by a powerful 180 W LED module!

Code : B04398



180W CW LED source
 motorised focus
 Beam opening: 12°
 3-facet rotating prism + linear prism wheel with 7 rotating gobos + open wheel with 9 fixed gobos + open wheel with 7 dichroic colours + open Frost filter
 Electronic dimmer variable from 0 to 100%
 DMX mode: 11 or 13 channels
 Synchronised shows (internal microphone)
 Master / Slave mode
 Drop-down menu display to assign and select different modes
 Wireless DMX: WTR-DMX dongle (optional)
 Power consumption: 230W
 Power supply: AC 100/230V - 50/60Hz
 Dimensions: 393x558x288 mm
 Net weight: 16.5 Kg



Cyclone-120R

Spot moving head with 120 W LED and multi-effects

Code : H10402



120W CW LED source
 manual focus
 Beam opening: 15°
 Strobe, pulse effect and random strobe
 3-facet rotating prism
 wheel with 6 rotating gobos + open wheel with 8 dichroic colours + open Electronic dimmer variable from 0 to 100%
 DMX mode: 1-16 channels
 Synchronised shows (internal microphone)
 Simplified control (EASY-2 compatible)
 Master / Slave mode
 Drop-down menu display to assign and select different modes
 Amplitude: 540° pan - 270° tilt
 Power consumption: 200W max.
 Power supply: AC 100/230V - 50/60Hz
 Dimensions: 292x169x425mm
 Net weight: 8 Kg



BT-METEOR

Compact and extremely bright LED moving head

Code : B04384



100W CW LED source
 motorised focus
 Beam opening: from 12° to 16°
 Strobe, pulse effect and random strobe
 3-facet rotating prism
 wheel with 6 rotating gobos + open wheel with 8 dichroic colours + open Electronic dimmer variable from 0 to 100%
 DMX mode: 5, 11 or 14 channels
 Synchronised shows (internal microphone)
 Master / Slave mode
 Drop-down menu display to assign and select different modes
 Wireless DMX: WTR-DMX dongle (optional)
 Power consumption: 160W
 Power supply: AC 100/230V - 50/60Hz
 Dimensions: 290x180x435mm
 Net weight: 8.75 Kg



MOVING HEAD CASE 1

Flight case for 2x BT-METEOR, BT-70LS, BT-BEAM70

Code : B03255



CASE for 2x BTX-HAWK

Flight case for 2x Briteq BTX-HAWK

Code : B03263



LIGHT EFFECT CASE 4

Flight case for 2x LYNX, 2x BT-20LS, 2x BT-30FC or 2x BT-W12L10 ZOOM

Code : B03225



FLY4Hezo300ZR

Flight case for 4x HEZO300ZR

Code : H10736



BT-METEOR

100 W LED - AIR DMX



MOVING HEADS



HEZO120Z

Wash moving head 12 x 10 W RGBW OSRAM®

Code : H10408



BT-ORBIT

Big brother of the very popular BT-W19L10 ZOOM with output increased by 65%.

Code : B04423



MOVING HEAD CASE 2

Flight case for 4 BT-Orbit / BT-W19 moving head

Code : B03272



12 10W RGBW LED sources
Opening from 10° to 60° by motorised lighted zoom: 2600 LUX at 5m at 10°
Programmable white balance
Colour preset, Colour macro Strobe, pulse effect and random strobe
Electronic dimmer variable from 0 to 100%
Motorised zoom from 10° to 60°
DMX mode: 1-30 channels
Synchronised shows (internal microphone)
Master / Slave mode
Drop-down menu display to assign and select different modes
Amplitude: 540° pan - 270° tilt
DMX IN / OUT by XLR 3/5-pin plugs
POWER IN/OUT with Powercon plugs
Power consumption: 198W maximum
Power supply: AC 100/230V - 50/60Hz
Dimensions: 263 x 183 x 340 mm
Net weight: 7.5 Kg

19 15W RGBW LED sources
Opening from 10° to 60° by motorised lighted zoom: 8400 LUX at 5m at 10°
Programmable white balance
Colour preset, Colour macro Strobe, pulse effect and random strobe
Electronic dimmer variable from 0 to 100%
Wireless DMX: WTR-DMX dongle (optional)
Independent control of three colour zones (outer ring, inner ring and central point)
DMX mode: 14 or 27 channels
Drop-down menu display to assign and select different modes
Amplitude: 540° pan - 270° tilt
DMX IN / OUT by XLR 3/5-pin plugs
POWER IN / OUT by Powercon plugs
Power consumption: 290W maximum
Power supply: AC 100/230V - 50/60Hz
Dimensions: 395 x 325 x 225 mm
Net weight: 9 Kg



Blast-60

Spot moving head with 60W LED

Code : H10312



CLUBSPOT

Compact moving head with 35W LED

Code : B05506

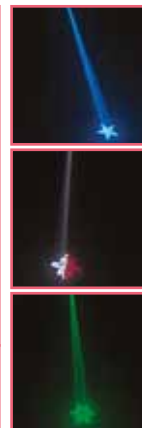

60W CW LED source
Manual focus
Beam opening from 14°
Strobe, pulse effect and random strobe
3-facet rotating prism
Wheel with 6 rotating gobos + open
Wheel with 8 dichroic colours + open
Electronic dimmer variable from 0 to 100%
DMX mode: 1, 8 or 12 channels
Synchronised shows (internal micro-

phone)
Simplified control (EASY-2 compatible)
Master / Slave mode
Drop-down menu display to assign and select different modes
Amplitude: 540° pan - 270° tilt
Power consumption: 70 W maximum
Power supply: AC 100/230V - 50/60Hz
Dimensions: 212 x 174 x 352 mm
Net weight: 5.3 Kg

35W CW LED source
Manual focus
12° opening
Stroboscopic effects
Wheel with 7 fixed gobos + open
Wheel with 7 dichroic colours + open
Electronic dimmer variable from 0 to 100%
DMX mode: 5, 9 or 11 channels
Wireless DMX: WTR-DMX dongle (optional)
Synchronised shows (internal microphone)

Master / Slave mode
Drop-down menu display to assign and select different modes
Amplitude: 540° pan - 270° tilt
DMX IN / OUT by XLR 3-pin plugs
POWER IN / OUT by IEC plugs
Power consumption: 60W maximum
Power supply: AC 100/230V - 50/60Hz
Dimensions: 284.5 x 205 x 149 mm
Net weight: 3.5 Kg



NINJA7i

Moving head with 7 4-colour 15W LEDs

Code : H10405



7 15W RGBW LED sources
 Opening from 10° to 20°
 Light: 4400 LUX at 5m at 10°
 Colour preset, Colour macro Strobe, pulse effect and random strobe
 Electronic dimmer variable from 0 to 100%
 Independent control of two colour zones (outer ring and central point)
 DMX mode: 16-25 channels
 Synchronised shows (internal microphone)
 Master / Slave mode
 Drop-down menu display to assign and select different modes
 Amplitude: 540° or 630° pan - 270° tilt
 Infinite PAN and TILT rotation
 DMX IN / OUT by XLR 3-pin plugs POWER IN / OUT by Powercon plugs
 Power consumption: 130W maximum
 Power supply: AC 100/230V - 50/60Hz
 Dimensions: 319 x 226 x 243 mm
 Net weight: 5 Kg



Ninja-7x15QC

Moving head with 7 4-colour 15W LEDs With diffuser filter and concentrator

Code : H10075



7 15W RGBW LED sources
 Source opening of 11° + Frost filter 20°
 Light: 4400 LUX at 5m at 10°
 Colour preset, Colour macro Strobe, pulse effect and random strobe
 Electronic dimmer variable from 0 to 100%
 Independent control of two colour zones (outer ring and central point)
 DMX mode: 15-21 channels
 Synchronised shows (internal microphone)
 Master / Slave mode
 Drop-down menu display to assign and select different modes
 Amplitude: 540° or 630° pan - 270° tilt
 DMX IN / OUT by XLR 3-pin plugs POWER IN / OUT by Powercon plugs
 Power consumption: 140W maximum
 Power supply: AC 100/230V - 50/60Hz
 Dimensions: 319 x 226 x 243 mm
 Net weight: 5.5 Kg



BT-W36L3

Wash moving head 36 x 3W (12R-12G-12B)

Code : B04344



36 3W LED sources (12 Red + 12 Green +12 Blue)
 12.5° opening
 Light: 5050 LUX at 5m at 12.5°
 Colour preset, Colour macro Strobe, pulse effect and random strobe
 Electronic dimmer variable from 0 to 100%
 DMX mode: 1-15 channels
 Synchronised shows (internal microphone)

Master / Slave mode
 Drop-down menu display to assign and select different modes
 Amplitude: 540° or 630° pan - 270° tilt
 DMX IN / OUT by XLR 3-pin plugs POWER IN / OUT by Powercon plugs
 Power consumption: 150W maximum
 Power supply: AC 100/230V - 50/60Hz
 Dimensions: 267 x 167 x 282 mm
 Net weight: 5.8 Kg



CASE FOR 4x BT-W36L3 / BT-W07L12

Flight case for 4x BT-W36L3 or BT-W07L12

Code : B03235



Fly4Ninja-S1

Flight case for 4 Ninja-7x15QC moving heads

Code : H10076



MOVING HEADS



TORNADO 7

Wash moving head 7 x 15W RGBW

Code : B04376



7 15W RGBW LED sources
6° opening
Light: 4400 LUX at 5m at 10°
Colour preset, Colour macro Strobe, pulse effect and random strobe
Electronic dimmer variable from 0 to 100%
Independent control of four zones
DMX mode: 17 and 34 channels
Synchronised shows (internal microphone)
Master / Slave mode
Drop-down menu display to assign and select different modes
Amplitude: 360° or 720° pan - 270° tilt
Infinite PAN and TILT rotation
DMX IN / OUT by XLR 3-pin plugs POWER IN by cord + 16A plug
Power consumption: 170W maximum
Power supply: AC 100/230V - 50/60Hz
Dimensions: 296 x 224 x 224 mm
Net weight: 4.7 Kg



STRIKER

LED spot (10°-30W-white) and wash (6 x 8W RVBW) moving head

Code : B04190



Spot 30W CW LED sources
Wash 6 8W RGBW LED sources
Beam opening 10° (Spot)
Motorised focus
wheel with 7 fixed gobos + open
wheel with 7 dichroic colours + open
Electronic dimmer variable from 0 to 100%
Stroboscopic effects
DMX mode: 5 or 19 channels
Wireless DMX: WTR-DMX dongle (optional)
Synchronised shows (internal microphone)
Master / Slave mode
Drop-down menu display to assign and select different modes
Amplitude: 540° pan - 270° tilt
DMX IN / OUT with 3-pin plugs
POWER IN by IEC plug + 16A plug
Power consumption: 95W max.
Power supply: AC 100/230V - 50/60Hz
Dimensions: 150x230x330mm
Net weight: 4.53 Kg



BT-W30FC Mk2

Wash moving head 3 x 10W RGBW

Code : B04371



3 10W RGBW LED sources
25° opening
Strobe, pulse effect and random strobe
Electronic dimmer variable from 0 to 100%
DMX mode: 9 or 16 channels
Synchronised shows (internal microphone)
Master / Slave mode
CA8 compatible (option)
Drop-down menu display to assign and select different modes
Amplitude: 540° pan - 270° tilt
DMX IN / OUT by XLR 3-pin plugs POWER IN by IEC plug + 16A plug
Power consumption: 57.4W maximum
Power supply: AC 100/230V - 50/60Hz
Dimensions: 272 x 231 x 248 mm
Net weight: 6 Kg



CLUBWASH

Wash moving head 7 x 12W RGBWAUV

Code : B05505



7 12W RGBWAUV LED sources
25° opening
Stroboscopic effects
Electronic dimmer variable from 0 to 100%
DMX mode: 5, 9 or 15 channels
Wireless DMX: WTR-DMX dongle (optional)
Synchronised shows (internal microphone)
Master / Slave mode
CA8 compatible (option)



CASE for 4x STRIKER

Flight case for 4x STRIKER

Code : B03267



Drop-down menu display to assign and select different modes
Amplitude: 160° pan - 90° tilt
DMX IN / OUT by XLR 3-pin plugs POWER IN / OUT by PowerCON plugs
Power consumption: 90W maximum
Power supply: AC 100/230V - 50/60Hz
Dimensions: 322.4 x 266.5 x 154 mm
Net weight: 3 Kg



FLAG25i

Moving head with 5x5 15W RGBW LEDs

Code : H10406



BEAM WIZARD5x5

Moving head with 5x5 15W RGBW LEDs

Code : B04417



ROTOR7i

Motorised bar with 7 15W RGBW LEDs

Code : H10407



25 15W RGBW (5 x 5) LED sources
4° opening per lens
Infinite PAN and TILT rotation
Light: 29700 LUX at 5m
Colour Preset and Macro
Patterns: letters, digits and figures with customisable colours
Automatic or musical programmes
Strobe, pulse effect and random strobe
Electronic dimmer variable from 0 to 100%
DMX mode: 16, 21 and 117 channels
Ethernet port: Art-NET/ KlingNET™
Drop-down menu display to assign and select different modes
Amplitude: 630° pan - 270° tilt
DMX IN / OUT by XLR 3/5-pin plugs
POWER IN / OUT by Powercon plugs
Ethernet IN/OUT by RJ45
Power consumption: 420W maximum
Power supply: AC 100/230V - 50/60Hz
Dimensions: 583 x 481 x 352 mm
Net weight: 18.6 Kg

25 15W RGBW (5 x 5) LED sources
4° opening per lens
Infinite PAN and TILT rotation
Light: 29700 LUX at 5m
Colour Preset and Macro
Patterns: letters, digits and figures with customisable colours
Automatic or musical programmes
Strobe, pulse effect and random strobe
Electronic dimmer variable from 0 to 100%
DMX mode: 12, 18, 110 and 116 channels
Ethernet port: Art-NET
Drop-down menu display to assign and select different modes
Amplitude: 630° pan - 270° tilt
DMX IN / OUT by XLR 3/5-pin plugs
POWER IN / OUT by Powercon plugs
Ethernet IN/OUT by RJ45
Power consumption: 420W maximum
Power supply: AC 100/230V - 50/60Hz
Dimensions: 583 x 481 x 352 mm
Net weight: 18.6 Kg

7 15W RGBW LED sources
4° opening per lens
Infinite PAN and TILT rotation
Light: 8100 LUX at 5m
Colour Preset and Macro
Patterns: letters, digits and figures with customisable colours
Automatic or musical programmes
Strobe, pulse effect and random strobe
Electronic dimmer variable from 0 to 100%
DMX mode: 15, 20 and 44 channels
Ethernet port: Art-NET/ KlingNET™
Drop-down menu display to assign and select different modes
Amplitude: 630° pan - 270° tilt
DMX IN / OUT by XLR 3/5-pin plugs
POWER IN / OUT by Powercon plugs
Ethernet IN/OUT by RJ45
Power consumption: 133W maximum
Power supply: AC 100/230V - 50/60Hz
Dimensions: 575 x 257 x 296 mm
Net weight: 9.6 Kg



FLY2FLAG25i

Flight case for 2 FLAG25i

Code : H10428



FLY2ROTOR7i

Flight case for 2 ROTOR7i

Code : H10429



CASE FOR BEAM WIZARD5x5

Flight case for 2x BT-BEAM WIZARD

Code : B03256



MOVING HEADS



DART90iZOOM
Moving head with 90W RGBW LED with zoom from 4° to 44° and continuous PAN and TILT movements

Code : H10594



90 W RGBW COB LED source
Opening from 4° to 44° by motorised zoom
Infinite PAN and TILT rotation
Light: 3800 LUX at 5m at 4°
Colour Preset and Macro
Automatic or musical programmes
Strobe, pulse effect and random strobe
Electronic dimmer variable from 0 to 100%
DMX mode: 13, 18 and 20 channels
Ethernet port: Art-NET/ KlingNET™
Drop-down menu display to assign and select different modes
Amplitude: 540° or 630° pan - 270° tilt
DMX IN / OUT by XLR 3-pin plugs POWER IN / OUT by Powercon plugs
Ethernet IN/OUT by RJ45
Power consumption: 120W maximum
Power supply: AC 100/230V - 50/60Hz
Dimensions: 304 x 236 x 186 mm
Net weight: 5.2 Kg



BEAM FURY-1
Moving head with 60W RGBW LED and continuous rotation

Code : B04394



60 W RGBW COB LED source
4° opening [10° and 45° filters included]
Infinite PAN and TILT rotation
Light: 5280 LUX at 5m at 4°
Colour Preset and Macro
Automatic or musical programmes
Strobe, pulse effect and random strobe
Electronic dimmer variable from 0 to 100%
DMX mode: 16 and 18 channels
Drop-down menu display to assign and select different modes
Amplitude: 540° or 630° pan - 270° tilt
DMX IN / OUT by XLR 3/5-pin plugs
POWER IN / OUT by Powercon plugs
Power consumption: 80W maximum
Power supply: AC 100/230V - 50/60Hz
Dimensions: 304 x 236 x 186 mm
Net weight: 5.3 Kg





DART60i
Moving head with 60W RGBW LED and continuous rotation

Code : H10490

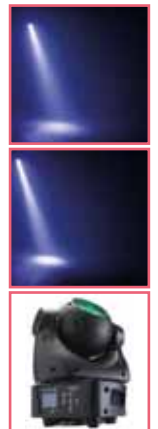

60 W RGBW COB LED source
4° opening [10° and 45° filters included]
Infinite PAN and TILT rotation
Light: 5280 LUX at 5m at 4°
Colour Preset and Macro
Automatic or musical programmes
Strobe, pulse effect and random strobe
Electronic dimmer variable from 0 to 100%
DMX mode: 16 and 18 channels
Drop-down menu display to assign and select different modes
Amplitude: 540° or 630° pan - 270° tilt
DMX IN / OUT by XLR 3/5-pin plugs
POWER IN / OUT by Powercon plugs
Power consumption: 80W maximum
Power supply: AC 100/230V - 50/60Hz
Dimensions: 304 x 236 x 186 mm
Net weight: 5.3 Kg



CASE for 6x BEAM FURY-1
Flight case for 6x BEAM FURY-1

Code : B03265



FLY-DARTx6
Flight case for 6 DART60i or DART60iZoom

Code : H10611



SCANNERS



VICTORYSCAN Mk2 LED

Scanner effect CREE 60 WATTS LED.

Code : B04054



60W CW LED source
 manual focus
 Beam opening: 17°
 wheel with 6 fixed gobos + open
 wheel with 8 dichroic colours + open
 Electronic dimmer variable from 0 to 100%
 DMX mode: 1, 7 or 8 channels
 Synchronised shows (internal microphone)
 Simplified control
 CA8 / RF-8SET compatible
 Master / Slave mode
 Drop-down menu display to assign and
 select different modes
 Power consumption: 105 W maximum
 Power supply: AC 100/230V - 50/60Hz
 Dimensions: 472 x 208 x 264 mm
 Net weight: 7.32 Kg



DYNABARREL

LED effect with rotating mirror

Code : B04187



10W RGBW LED source
 manual focus
 DMX mode: 1 or 9 channels
 Synchronised shows (internal microphone)
 Simplified control: CA8 compatible
 Master / Slave mode
 DMX IN / OUT by XLR 3-pin plugs POW-
 ER IN / OUT by IEC plugs
 Power supply: AC 100/230V - 50/60Hz
 Dimensions: 331 x 170 x 120 mm
 Net weight: 2.95 Kg



LIGHT EFFECT CASE 3

Flight case for 2x LED CLUBSCAN or 2x
 DYNAMO scan

Code : B03223



LIGHT EFFECT CASE 7

For The Winner II, Led Victoryscan Led
 Spinner....

Code : B03233



MOVING HEAD COMPARISON

Hybrid Beam/Spot/Wash moving heads

REF	NAME	Brand	Source	Auto Programme	CMY	Colour wheel	Rotating interchangeable gobos	Fixed gobos	Rotating circular prism
B04378	BTX-TITAN	Briteq	HRI280 280W	no	no	13 colours (CTO + CTB)	9 gobos	14 gobos	combinable 8 facets
B04428	BTX-Saturn	Briteq	270W LED	no	yes	9 colours (CTO + CTB + UV)	7 gobos	9 gobos	3 facets
H10661	FUSION180	Contest	180W LED	yes	-	10 colours	9 gobos	15 gobos	8 facets

Beam moving heads

REF	NAME	Brand	Source	Beam Opening	Auto Programme	PAN / TILT Macro	Colour wheel	Gobos	Rotating circular prism
B04353	BTX-BEAM 5R	Briteq	5R 189W	1° - 3.8°	no	yes	14 colours	17 gobos	8 facets
H10409	SWORD5R	Contest	5R 189W	3.5°	yes + sound	yes	14 colours	17 gobos	8 facets
H10410	RAY1R	Contest	HRI-100 100W	3°	yes + sound	yes	14 colours	15 gobos	8 facets
B04387	BT-TRACKER	Briteq	HRI-100 100W	3°	sound	-	14 colours	15 gobos	8 facets
H10176	Thunder-80	Contest	80W LED	6°	yes + sound	yes	8 colours	7 rotating gobos	-

Spot moving heads

REF	NAME	Brand	Source	Beam Opening	USB Port for B04645 WiFi dongle	Auto Programme	PAN / TILT Macro	Colour wheel	Rotating interchangeable gobos
B04398	BTX-HAWK	Briteq	180W LED	12°	yes	yes	-	7 colours	7 gobos
H10402	Cyclone120R	Contest	120W LED	15°	-	yes	yes	8 colours	6 gobos
B04384	BT-METEOR	Briteq	100W LED	12° to 16°	yes	yes	-	8 colours	6 gobos
H10175	Cyclone-80	Contest	80W LED	15°	-	yes	yes	8 colours	-
H10312	BLAST-60	Contest	60W LED	14°	-	yes	yes	8 colours	6 gobos
B05506	CLUBSPOT	JB Systems	35W LED	12°	yes	yes	-	7 colours	-

Wash / Beam LED moving heads

REF	NAME	Brand	LED source	Beam Opening	Continuous Pan/Tilt rotation	USB Port for B04645 WiFi dongle	Auto Programme	PAN / TILT Macro	Colour wheel
B04423	BT-ORBIT	Briteq	19x15W RGBW	10° to 60°	-	yes	-	-	-
B04359	BT-W19L10 ZOOM	Briteq	19x10W RGBW	10° to 60°	-	-	-	-	-
H10408	HEZ0120Z	Contest	12x10W RGBW	10° to 60°	-	-	yes	yes	-
H10405	Ninja7i	Contest	7x15W RGBW	11°-20°	yes	-	yes	-	-
H10075	Ninja-7x15QC	Contest	7x15W RGBW	9°-11°-20°	-	-	yes	-	-
B04344	BT-W36L3	Briteq	12xR-12xG-12xB 3W	12.5°	-	-	yes	yes	-
B04376	TORNADO 7	Briteq	7x15W RGBW	6°	yes	-	yes	-	-
B04371	BT-W30FC Mk2	Briteq	3x10W RGBW	25°	-	-	yes	yes	-
B05505	CLUBWASH	JB Systems	7x12W RGBWA+UV	25°	-	yes	yes	-	-
B04190	STRIKER	JB Systems	30W White 6x8W RGBW	10° spot	-	yes	yes	yes	7 colours

LED effect moving heads

REF	NAME	Brand	LED source	Beam Opening	Continuous Pan/Tilt rotation	Art-NET compatibility	Auto Programme	Multi zones pixel	Motorised zoom
H10406	FLAG25i	Contest	25x15W QC	25x 4.5°	yes	yes RJ45 IN/OUT	yes	25	-
B04417	BEAM WIZARD5x5	Briteq	25x15W QC	25x 4.5°	yes	yes RJ45 IN/OUT	yes	25	-
H10407	ROTOR7i	Contest	7x15W QC	7x 4°	yes	yes RJ45 IN/OUT	yes	7	-
H10594	DART90i ZOOM	Contest	90W	4° to 44°	yes	yes RJ45 IN/OUT	yes	-	yes
B04394	BEAM FURY-1	Briteq	60W	4°-10°45°	yes	-	-	-	-
H10490	DART60i	Contest	60W	4°-10°45°	yes	-	yes	-	-

Linear rotating prism	Iris	Frost	Zoom Beam - Spot	Focus	Number of DMX channels	Battery for adjusting with power off	DMX XLR	Power supply	Weight	Flight case compatible
combinable 6 facets	no	Linear	2.7° to 23°	yes	16-24-25	yes	3 and 5 pin	Powercon IN - OUT	22Kg	B03251
-	yes	Linear	8° to 45°	yes	25	no	3 and 5 pin	Powercon TRUE1 IN - OUT	22.7 kg	B03273
6 facets	-	Linear	6 to 21°	yes	17-19-20	yes	3 and 5 pin	Seetronic IN - OUT	18Kg	H10737

Trapezoidal rotating prism	Frost	Focus	Number of DMX channels	Battery for adjusting with power off	DMX XLR	Power supply	Weight	Flight case compatible
-	yes	yes	19	yes	3 and 5 pin	Powercon IN - OUT	20Kg	B03239
-	yes	yes	1-12-16	-	3 pin	Powercon IN - OUT	18Kg	B03239
-	-	-	1-10-14	-	3 pin	Powercon IN - OUT	9.2Kg	H10610
-	-	-	5-12	-	3 pin	Powercon IN - OUT	9.7Kg	B03264
-	-	-	1-8-11	-	3 pin	IEC IN - OUT	8Kg	H10247

Fixed gobos	Rotating circular prism	Linear Prism	Frost	Focus	Number of DMX channels	Battery for adjusting with power off	DMX XLR	Power supply	Weight	Flight case compatible
9 gobos	3 facets	yes	yes	motorised	5-13-15	yes	3 and 5 pin	Powercon IN - OUT	15.5Kg	B03263
-	3 facets	-	-	manual	1-10-16	-	3 pin	IEC IN - OUT	8Kg	H10247
-	3 facets	-	-	motorised	5-11-14	-	3 pin	Powercon IN - OUT	8.75Kg	B03255
7 gobos	3 facets	-	-	manual	1-9-15	-	3 pin	IEC IN - OUT	8Kg	H10247
-	-	-	-	manual	1-8-12	-	3 pin	IEC IN - OUT	5.3Kg	H10247
7 gobos	-	-	-	manual	5-8-11	-	3 pin	IEC IN	3.5Kg	Coming soon

Gobo Wheel	Multi zones pixel	Motorised Zoom / Focus	Number of DMX channels	Battery for adjusting with power off	DMX XLR	Power supply	Weight	Flight case compatible
-	3	Zoom	14a-14b-27	-	3 and 5 pin	Powercon IN - OUT	9.2Kg	B03272
-	-	Zoom	14a-14b	-	3 and 5 pin	Powercon IN - OUT	9.2Kg	B03272
-	-	Zoom	1-12-17	-	3 and 5 pin	Powercon IN - OUT	7.5Kg	H10610
-	2	-	16-20-25	yes	3 pin	Powercon IN - OUT	5.5Kg	H10076
-	2	-	15-17-21	yes	3 pin	Powercon IN - OUT	5.5Kg	H10076
-	-	-	1-4-8-12-15	-	3 pin	Powercon IN - OUT	5.8Kg	B03235
-	4	-	17-34	-	3 pin	Power cable	4.7Kg	B03247
-	-	-	1-4-1-9-16	-	3 pin	IEC IN - OUT	4.2Kg	B03225
-	-	-	5-9-15	-	3 pin	IEC IN	3 kg	Coming soon
7 gobos	Spot / Wash	Focus	5-19	-	3 pin	IEC IN	4.5Kg	B03267

Number of DMX channels	Battery for adjusting with power off	DMX XLR	Power supply	Weight	Flight case compatible
16-21-117	yes	3 and 5 pin	Powercon IN - OUT	20Kg	H10428
12-18-110-116	yes	3 and 5 pin	Powercon IN - OUT	20Kg	B03256
15-20-44	yes	3 and 5 pin	Powercon IN - OUT	9.6Kg	H10429
13-18-20	yes	3 and 5 pin	Powercon IN - OUT	5.3Kg	H10611
12-14	yes	3 and 5 pin	Powercon IN - OUT	6.2Kg	B03265
12-17-19	yes	3 and 5 pin	Powercon IN - OUT	5.3Kg	H10611



ANIMATION EFFECTS



Heliptic-9x10WH

Animation projector with 3x3 white beams and continuous PAN

Code : H10311



9 10W White LED sources
 Beam opening 6° per lens
 Strobe, pulse effect and random strobe
 Electronic dimmer variable from 0 to 100%
 DMX mode: 1, 11, 16 and 15 channels
 Synchronised shows (internal microphone)
 Simplified control (EASY-2 compatible)
 Master / Slave mode
 Drop-down menu display to assign and select different modes
 Independent rotation of each bar
 Bar rotation over 145°
 Continuous PAN rotation
 DMX IN / OUT by XLR 3-pin plugs POWER IN / OUT by IEC plugs
 Power consumption: 106W max.
 Power supply: AC 100/230V - 50/60Hz
 Dimensions: 429 x 347 x 208 mm
 Net weight: 9.6 Kg



Heliwave-8x10WH

Animation light bars with 2x4 white beams and continuous PAN

Code : H10293



8 10W White LED sources
 Beam opening 6° per lens
 Strobe, pulse effect and random strobe
 Electronic dimmer variable from 0 to 100%
 DMX mode: 1, 10, 14 and 18 channels
 Synchronised shows (internal microphone)
 Simplified control (EASY-2 compatible)
 Master / Slave mode
 Drop-down menu display to assign and select different modes
 Independent rotation of each bar
 Bar rotation over 145°
 Continuous PAN rotation
 DMX IN / OUT by XLR 3-pin plugs POWER IN / OUT by IEC plugs
 Power consumption: 106W max.
 Power supply: AC 100/230V - 50/60Hz
 Dimensions: 393 x 232 x 239 mm
 Net weight: 9.6 Kg



FLY-HELIWAVEx2

Flight case for 2 HELIWAWE

Code : H10340



Storm-8x10WH

Moving head with double animation ramp. The madness of the white multibeam

Code : H10173



8 10W White LED sources
 Beam opening 6° per lens
 Strobe, pulse effect and random strobe
 Electronic dimmer variable from 0 to 100%
 DMX mode: 1-13 channels
 Synchronised shows (internal microphone)
 Simplified control (EASY-2 compatible)
 Master / Slave mode
 Drop-down menu display to assign and select different modes
 Panoramic movement
 Independent rotation of each bar
 Amplitude: 540° pan - Bar rotation over 230°
 DMX IN / OUT by XLR 3-pin plugs POWER IN / OUT by IEC plugs
 Power consumption: 100W max.
 Power supply: AC 100/230V - 50/60Hz
 Dimensions: 414x153x376mm
 Net weight: 6.5 Kg

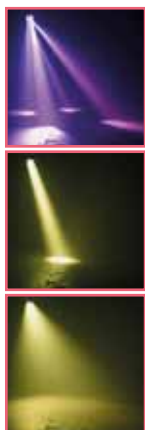

Kadeo460QC

DMX projector with 4 60W 4-in-1 RGBW LEDs with zoom and effect

Code : H10652



4 60W RGBW LED sources
 Rotating lens: Indexable, infinity and variable shake
 Beam opening in Par mode from 6° to 80° by motorised zoom
 RGBW setting and colour macros
 Electronic dimmer variable from 0 to 100%
 DMX mode: 1, 10 or 12 channels
 Synchronised shows (internal microphone)
 Simplified control (EASY-2 compatible)

Master / Slave mode
 Drop-down menu display to assign and select different modes
 Independent rotation of each bar over 145°
 DMX IN / OUT by XLR 3-pin plugs POWER IN by cord and 16A plugs
 Power consumption: 350W max.
 Power supply: AC 100/230V - 50/60Hz
 Dimensions: 342 x 320 x 305 mm
 Net weight: 6.3 Kg



CASE for 2x BT-DAZZLE

Flight case for 2x BT-DAZZLE.

Code : B03258



ANIMATION EFFECTS



BT-DAZZLE

Endless rotating multibeam effect: 4x 9W White L

Code : B04388



Mains power input: 100 - 240 V AC, 50/60 Hz
 Power consumption: 71 W
 Sound control: Internal microphone
 Panoramic/tilt: infinite/220°
 Beam angle: 3.5°
 DMX connections: XLR 3 male/female
 LED: 4 white LEDs 8 W
 Dimensions: 497 x 187 x 306 mm
 Weight: 9.6 kg



PIXEL PIPE

RGB LED tube 1m with DMX and IR remote

Code : B06204



Power supply: 100-240 V AC, 50/60 Hz
 Power consumption: 12 W

Power interconnection (IEC input/output)
 : maximum link load = 6 A
 Sound control: Internal microphone

DMX connections: 3-pin male/female
 XLR male to female
 DMX mode: 3, 7, 24 DMX channels
 LED light source: 32 RGB LED SMD5050
 Dimensions: 105 x 20 x 20 x 22 cm
 Weight: 1.24 kg

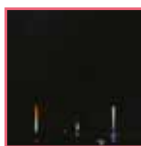

HEXAGON 3D

3D Hexagonal RGB wall mirror effect

Code : B06205



Power supply: 100 to 240 V AC, 50/60Hz
 Fuse: Slow fuse 250 V 2 A (glass 20 mm)
 Maximum power consumption: 50 W
 Sound control: Internal microphone
 DMX connections: XLR 3-pin male/female
 No. of DMX channels: 3 and 9 channels

LED: 72 x red-green-blue LED 1.5 W
 Dimensions: 404 x 352 x 97 mm
 Weight: 3.2 kg



LED GLOBE

Rotating effect with 98 beams. 5x 2W RGBW LED

Code : B06202



Power supply: 100 to 240 V AC, 50/60Hz
 Fuse: 250 V 1.6A slow-blow (20 mm glass)
 Total consumption: 60 w
 Sound control: Internal microphone
 DMX connections: XLR 3-pin male/female
 No. of DMX channels: 1, 3, 9 or 19 channels
 LED power: 5 RGB LEDs + White 8 W
 Dimensions: 397 x 397 x 397 x 510mm
 Weight: 4,23kg



LED HELICOPTER

Rotating effect with 6x RGBW projectors

Code : B06203



Power supply: 100 to 240 V AC, 50/60Hz
 Fuse: Slow fuse 250 V T1.6 A (20 mm glass) Total consumption: 60W
 Sound control: Internal microphone
 DMX connections: XLR 3-pin male/female
 No. of DMX channels: 3 or 11 channels
 PAR projector power: 6 projectors with 8 W RGBW LED
 Beam angle: 7°
 Dimensions: 390x360x360x240 mm
 Weight: 4,16kg



ANIMATION EFFECTS



Firestorm-4x10WH

Bar with 4 10W white LED projectors with Pan and Tilt Movements

Code : H10291



4 10W White LED sources
 Beam opening 6° per lens
 Strobe, pulse effect and random strobe
 Electronic dimmer variable from 0 to 100%
 DMX mode: 1, 11A, 11B and 15 channels
 Synchronised shows (internal microphone)
 Simplified control (EASY-2 compatible)
 Master / Slave mode
 Drop-down menu display to assign and select different modes
 TILT movement of the bar
 Independent PAN movement over 90° for each projector
 DMX IN / OUT by XLR 3-pin plugs POW-ER IN / OUT by IEC plugs
 Power consumption: 80W max.
 Power supply: AC 100/230V - 50/60Hz
 Dimensions: 791 x 152 x 232 mm
 Net weight: 10.2 Kg



Firestorm-4x10QC

Bar with 4 10W RGBW LED projectors with Pan and Tilt Movements

Code : H10292



4 10W RGBW LED sources
 Beam opening 6° per lens
 Strobe, pulse effect and random strobe
 Electronic dimmer variable from 0 to 100%
 DMX mode: 1, 11, 23 and 27 channels
 Synchronised shows (internal microphone)
 Simplified control (EASY-2 compatible)
 Master / Slave mode
 Drop-down menu display to assign and select different modes
 TILT movement of the bar
 Independent PAN movement over 90° for each projector
 DMX IN / OUT by XLR 3-pin plugs POW-ER IN / OUT by IEC plugs
 Power consumption: 78W max.
 Power supply: AC 100/230V - 50/60Hz
 Dimensions: 791 x 232 x 152 mm
 Net weight: 10.2 Kg



RADIUS-515

Beam effect with 5 15W 4-in-1 RGBW LEDs

Code : H10667



5 15W RGBW LED sources
 Beam opening 4° per lens
 Automatic or musical programmes
 DMX control: 1, 9, 12 or 28 channels
 Drop-down menu display to assign and select different modes
 Bar rotation over 240°
 DMX IN / OUT by XLR 3-pin plugs POW-ER IN / OUT by IEC plugs
 Power consumption: 80W max.
 Power supply: AC 100/230V - 50/60Hz
 Dimensions: 525 x 280 x 250 mm
 Net weight: 5.870 kg

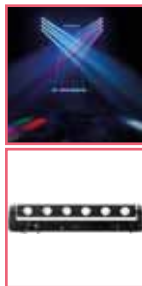

Swell-6x10WH

Rotating multibeam bar with 6 white 10 W LEDs

Code : H10260



6 10W White LED sources
 Beam opening 6° per lens
 Strobe, pulse effect and random strobe
 Electronic dimmer variable from 0 to 100%
 DMX mode: 1-13 channels
 Synchronised shows (internal microphone)
 Simplified control (EASY-2 compatible)
 Master / Slave mode
 Drop-down menu display to assign and select different modes
 Bar rotation over 240°
 DMX IN / OUT by XLR 3-pin plugs POW-ER IN / OUT by IEC plugs
 Power consumption: 64.5W max.
 Power supply: AC 100/230V - 50/60Hz
 Dimensions: 843 x 170 x 84 mm
 Net weight: 4.9 Kg



SUPER LED RAINBOW

Powerful multibeam LED effects

Code : B04171



6 10W RGBW LED sources
 Beam opening 9° per lens
 Synchronised shows (internal microphone)
 Automatic or musical programmes
 Master / Slave mode
 DMX control: 1, 8 or 28 channels
 Simplified control (CA-8 compatible)
 Drop-down menu display to assign and select different modes
 DMX IN / OUT by XLR 3-pin plugs POW-ER IN / OUT by IEC plugs
 Power consumption: 80.6W max.
 Power supply: AC 100/230V - 50/60Hz
 Dimensions: 418 x 233 x 122 mm
 Net weight: 4.18 kg



Beam-4x10QC

Multibeam coloured light bar 4x10W
 Compact multi-beam effect

Code : H10179



4 10W RGBW LED sources
 Beam opening 6° per lens
 Strobe, pulse effect and random strobe
 Electronic dimmer variable from 0 to 100%
 DMX mode: 1-18 channels
 Synchronised shows (internal microphone)
 Simplified control (EASY-2 compatible)
 Master / Slave mode
 Drop-down menu display to assign and select different modes
 DMX IN / OUT by XLR 3-pin plugs POW-ER IN / OUT by IEC plugs
 Power consumption: 45W max.
 Power supply: AC 100/230V - 50/60Hz
 Dimensions: 380x165x80mm
 Net weight: 2.7 Kg



FLASHBEAM

Double light bar with 8 9W TRI LEDs and 4 white Flash LEDs

Code : H10481



SUPER QUADRA BEAM

Extremely dynamic scanning LED

Code : B04180



SUPER ORION

Extremely dynamic scanning LED effect

Code : B04179



8 9W RGB LED sources
Beam opening 3° per lens + 4 White 1W LEDs (stroboscope)
Pre-programmed shows, Colour control and stroboscopic LEDs
Electronic dimmer variable from 0 to 100%
Master / Slave mode
DMX mode: 1, 4, 14 or 15 channels
DMX IN / OUT by XLR 3-pin plugs POWER IN / OUT by IEC plugs
Power consumption: 76W max.
Power supply: AC 100/230V - 50/60Hz
Dimensions: 605 x 184 x 268 mm
Net weight: 3.2 kg

4 groups of 9 pcs 1W LEDs (8 x red, 8 x green, 8 blue, 12 x white)
Synchronised shows (internal microphone)
Automatic or musical programmes
Master / Slave mode
DMX control: 1 or 3 channels
Simplified control (CA-8 compatible)
Drop-down menu display to assign and select different modes
DMX IN / OUT by XLR 3-pin plugs POWER IN / OUT by IEC plugs
Power consumption: 66 W max.
Power supply: AC 100/230V - 50/60Hz
Dimensions: 830 x 171 x 202 mm
Net weight: 5 kg

4 groups of 9 pcs 1W LEDs (8 x red, 8 x green, 8 blue, 12 x white)
Synchronised shows (internal microphone)
Automatic or musical programmes
Master / Slave mode
DMX control: 1 or 3 channels
Simplified control (CA-8 compatible)
Drop-down menu display to assign and select different modes
DMX IN / OUT by XLR 3-pin plugs POWER IN / OUT by IEC plugs
Power consumption: 67 W max.
Power supply: AC 100/230V - 50/60Hz
Dimensions: 430 x 256 x 172 mm
Net weight: 4.1 kg



ORION

LED effect

Code : B04143



ALIEN

LED effect + UV + stroboscope + laser

Code : B06200



BEAM TWISTER

Compact and innovative LED projector

Code : B04183



4 groups with a total of 224 LEDs (80 red, 60 green, 48 blue, 36 white)
Synchronised shows (internal microphone)
Automatic or musical programmes
Master / Slave mode
DMX control: 1, 4 and 7 channels
Simplified control (CA-8 compatible)
Drop-down menu display to assign and select different modes
DMX IN / OUT by XLR 3-pin plugs POWER IN / OUT by IEC plugs
Power consumption: 30 W max.
Power supply: AC 100/230V - 50/60Hz
Dimensions: 475 x 290 x 160 mm
Net weight: 5.3 kg

3 projectors with 9 8 W RGB+UV LEDs
Effect with 84 0.75 W RGBA LEDs
Stroboscopic: 12 0.5 W white LEDs
Laser: red (100 mW) and green (30 mW) laser motifs
IR remote control included
Synchronised shows (internal microphone)
Automatic or musical programmes
Master / Slave mode
DMX control: 3, 9, 11 or 28 channels
Drop-down menu display to assign and select different modes
DMX IN / OUT by XLR 3-pin plugs POWER IN / OUT by IEC plugs
Power consumption: 66 W max.
Power supply: AC 100/230V - 50/60Hz
Dimensions: 830 x 171 x 202 mm
Net weight: 5 kg

32W RGBW LED source
Synchronised shows (internal microphone)
Automatic or musical programmes
Master / Slave mode
DMX control: 1 or 4 channels
Simplified control (CA-8 compatible)
Drop-down menu display to assign and select different modes
DMX IN / OUT by XLR 3-pin plugs POWER IN / OUT by IEC plugs
Power consumption: 50W max.
Power supply: AC 100/230V - 50/60Hz
Dimensions: 350 x 352 x 203 mm
Net weight: 3.3 kg



ANIMATION EFFECTS



GOBOBEAM

Animation effect with 8 3W LEDs with projection of moving gobos

Code : H10662

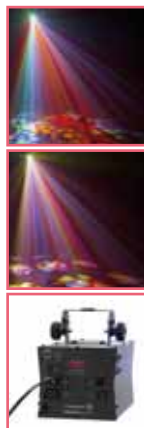

INVADER

Multieffect: 23W LED eff. + 200mW red+green laser

Code : B04176



LED-BEAMER

Derby with 2 3-colour 9W LEDs

Code : H10023



8 3W RGBA LED sources
Synchronised shows (internal microphone)
Automatic or musical programmes
Master / Slave mode
DMX control: 1, 8 or 12 channels
Simplified control (EASY-2 compatible)
Drop-down menu display to assign and select different modes
DMX IN / OUT by XLR 3-pin plugs POW-ER IN / OUT by IEC plugs
Power consumption: 40W max.
Power supply: AC 100/230V - 50/60Hz
Dimensions: 290 x 160 x 220 mm
Net weight: 3 kg

Effect with 5 3 W RGBWA LEDs
Stroboscopic: 8 1 W white LEDs
Laser: red (150 mW) and green (50 mW) laser motifs
Synchronised shows (internal microphone)
Automatic or musical programmes
Master / Slave mode
DMX control: 1 or 9 channels
Drop-down menu display to assign and select different modes
DMX IN / OUT by XLR 3-pin plugs POW-ER IN / OUT by IEC plugs
Power consumption: 66 W max.
Power supply: AC 100/230V - 50/60Hz
Dimensions: 240 x 220 x 110 mm
Net weight: 3.75 kg

2 9W RGB LED sources
Modes of operation:
- Independent
- Musical (internal microphone)
Power consumption: 20W
Power supply: AC 100/230V - 50/60Hz
Dimensions: 310 x 205 x 310 mm
Net weight: 3.4 kg



PARTY DERBY

Compact projector with 2 different led effects

Code : B04186



LED AQUA

25W LED water simulator

Code : B04545



LED VIRTUAL FLAME

Flame simulator 36cm diameter

Code : B04544



Derby LED effect
Stroboscopic: 16 white LEDs
IR remote control included
Synchronised shows (internal microphone)
Automatic or musical programmes
Master / Slave mode
DMX control: 1 or 5 channels
Drop-down menu display to assign and select different modes
DMX IN / OUT by XLR 3-pin plugs POW-ER IN / OUT by IEC plugs
Power consumption: 28 W max.
Power supply: AC 100/230V - 50/60Hz
Dimensions: 190 x 258 x 182 mm
Net weight: 1.72 kg

25W White LED source
6 progressively changing colours
The colour change can be blocked on 1 colour
Adjustable focus
Power consumption: 43.3W max.
Power supply: AC 100/230V - 50/60Hz
Dimensions: 255 x 245 x 196 mm
Net weight: 3.4 kg

Equipped with 5 1W LED light emitting diodes
The nearly silent fan allows a flame to be projected to a height of about 35 cm
Place it on a flat surface or hang it with the set of fine mesh chains provided.
Diameter of the fire cup: 36 cm
Power consumption: 16.5W max.
Power supply: AC 100/230V - 50/60Hz
Net weight: 3.55 kg

ANIMATION EFFECTS



NW

BEAMSPOT-4BAR NW

T-BAR with 4 BEAMSPOT NW 4500K

Code : B05508



4 white 15W 4500K LED sources
4° opening (10° and 45° filters included)
Electronic dimmer from 0 to 100%
2 Mode dimmer: Slow, Fast
4 Dimmer curves (LINEAR, SQUARE, INV.SQUARE, S-CURVE)
DMX mode: 1, 2, 4 or 5 channels
Wireless DMX: WTR-DMX dongle (optional)
Drop-down menu display
DMX IN / OUT by XLR 3/5-pin plugs
POWER IN / OUT by PowerCON plugs
Spigot support 28mm
Power supply: AC 100/230V - 50/60Hz
Dimensions: 552 x 85 x 315 mm
Net weight: 6.74 Kg



WW

BEAMSPOT-4BAR WW

T-BAR with 4 BEAMSPOT WW 3200K

Code : B05507



4 15W Warm white 3200K LED sources
4° opening per lens (10° and 45° filters included)
Electronic dimmer variable from 0 to 100%
2 Mode dimmer: Slow (halogen), Fast (LED)
4 Dimmer curves (LINEAR, SQUARE, INV.SQUARE, S-CURVE)
DMX mode: 1, 2, 4 or 5 channels
Wireless DMX: WTR-DMX dongle (optional)
Drop-down menu display to assign and select different modes
DMX IN / OUT by XLR 3/5-pin plugs
POWER IN / OUT by PowerCON plugs
Spigot support 28mm
Power consumption: 71W max.
Power supply: AC 100/230V - 50/60Hz
Dimensions: 552 x 85 x 315 mm
Net weight: 6.74 Kg



PARTY BAR

The PARTY BAR is a fabulous set of 4-in-1 lights for mobile DJs!

Code : B04184



2 Derby effects equipped with a 3 W RGB LED
2 projectors with 3 RGB 9 W LEDs
4 cool white LEDs to create stroboscopic effects
The bi-colour red/green laser
IR remote control included
Synchronised shows (internal microphone)
Automatic or musical programmes
Master / Slave mode
DMX control: 3, 5, 6, 9 or 27 channels
Wireless DMX: WTR-DMX dongle (optional)
Drop-down menu display to assign and select different modes
DMX IN / OUT by XLR 3-pin plugs POWER IN / OUT by IEC plugs
Power consumption: 48 W max.
Power supply: AC 100/230V - 50/60Hz
Dimensions: 1185 x 386 x 110 mm
Net weight: 8.35 kg



CASE FOR 4x BEAMSPOT-4BAR

Flight case for 4 x Beamspot-4Bar

Code : B03275



PARTY BEAMS

This extremely compact bar is equipped with two different light effects to create superb light effects

Code : B04185



8 9W RGB LED sources
Beam opening 7° per lens + 4 White 1W LEDs (stroboscope)
Pre-programmed shows, Colour control and stroboscopic LEDs
Electronic dimmer variable from 0 to 100%
Master / Slave mode

DMX mode: 3, 9 or 14 channels
DMX IN / OUT by XLR 3-pin plugs POWER IN / OUT by IEC plugs
Power consumption: 76W max.
Power supply: AC 100/230V - 50/60Hz
Dimensions: 605 x 184 x 268 mm
Net weight: 3.2 kg



ANIMATION EFFECTS



SUPER BOOGIE
Double Led Flower DMX

Code : B04178



SUPER ATLAS
Flower LED 9 x 1Watt

Code : B04177



LED MOON
Rotating Flower Effect with extremely compact LED

Code : B04174



Equipped with 2 sets of 9 1 Watt LEDs (4 x red, 4 x green, 4 blue, 6 x white)
Synchronised shows (internal microphone)
Automatic or musical programmes
Master / Slave mode
DMX control: 1 or 3 channels
Simplified control (CA-8 compatible)
Drop-down menu display to assign and select different modes
DMX IN / OUT by XLR 3-pin plugs POWER IN / OUT by IEC plugs
Power consumption: 35 W max.
Power supply: AC 100/230V - 50/60Hz
Dimensions: 246 x 230 x 164 mm
Net weight: 2.6 kg

Equipped with 9 1 Watt LEDs (2 x red, 2 x green, 2 blue, 3 x white)
Automatic programmes (internal microphone)
Consumption: 20 W max.
Power supply: AC 100/230V - 50/60Hz
Dimensions: 141 x 224 x 203 mm
Net weight: 1.4 kg

Rotating Flower effect equipped with one 3 Watt LED
Plug & play
3 operating modes: Static, automatic rotation, activated to the rhythm of the music.
Double reflector
Internal microphone
External power supply transformer
Consumption: 10 W max.
Power supply: AC 100/230V - 50/60Hz
Dimensions: 195 x 165 x 134 mm
Net weight: 0.64 kg



LED DIAMOND II
A LED projector controlled by very attractive and compact DMX

Code : B04188



NightBall
Half-sphere with 3 1W RGB LEDs with infrared remote control

Code : H10711

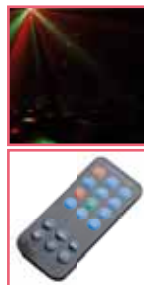

NightMotion
Mushroom type animation effect with 3 3W RGB LEDs With infrared remote control

Code : H10645



6 3W LED sources (1 red + 1 green + 1 blue + 1 white + 1 orange + 1 violet)
The various lenses project many beams of clean colour over more than 360 degrees
Synchronised shows (internal microphone)
Automatic or musical programmes
Master / Slave mode
DMX control: 1 or 6 channels
Drop-down menu display to assign and select different modes
DMX IN / OUT with 3-pin plugs
Power consumption: 24 W max.
Power supply: AC 100/230V - 50/60Hz
Dimensions: dia 190 x 175 mm
Net weight: 0.42 kg

3 RGB 1W LEDs
Automatic mode
Sound mode
Weight: 0.195 Kg
Power consumption: 5W
Dimensions: 125 x 105 x 120 mm
AC 240V - 50Hz / 5 V DC adaptor supplied

3 RGB 3W LEDs
Automatic mode
Sound mode
Weight: 0.950 Kg
Power consumption: 10W
Dimensions: 180 x 160 x 190 mm
AC 240V - 50Hz / 12 V DC adaptor supplied



NightFlower

Flower type animation effect with 9W RGB LED With infrared remote control

Code : H10646



13-in-1 RGB 9W LED
Automatic mode
Sound mode
Weight: 0.950 Kg
Power consumption: 10W
Dimensions: 180 x 160 x 190 mm
AC 240V - 50Hz / 12 V DC adaptor supplied



NightColor

Wash projector with 3 1W RGB LEDs With infrared remote control

Code : H10648



3x1W 1R 1G 1B LED
Automatic mode
Sound mode
Weight: 0.55 Kg
Power consumption: 5W
Dimensions: 190 x 60 x 110 mm
AC 240V - 50Hz / 12 V DC adaptor supplied

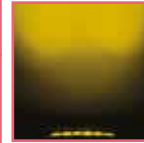

LED MARVEL LED Projector

Code : B04543



6 LED panels
216 LEDs (72 red, 72 green, 72 blue)
Static or sound-activated programmes (internal microphone)
IR remote control included
Control by DMX possible: 21 channels
Weight: 0.6 Kg
Power consumption: 12W
Dimensions: 68 x 39 x 434 mm
AC 240V - 50Hz / 12 V DC adaptor supplied



NightFluo

Bar with 5 UV 1W LEDs and 4 Flash LEDs With infrared remote control

Code : H10649



5 UV LEDs
4 Flash LEDs
Automatic mode
Sound mode
Weight: 0.245 Kg
Power consumption: 12W
Dimensions: 530 x 40 x 60 mm
AC 240V - 50Hz / 12 V DC adaptor supplied



LED POLICE LIGHT BLUE

Blue LED rotating beacon

Code : B04540



Rotating beacon with 108 extremely brilliant LEDs
Adjustable rotation speed
Weight: 0.86 Kg
Dimensions: dia 143 x 182 mm
AC 240V - 50Hz / 12 V DC adaptor supplied



LED POLICE LIGHT RED

Red LED rotating beacon

Code : B04541



Rotating beacon with 108 extremely brilliant LEDs
Adjustable rotation speed
Weight: 0.86 Kg
Dimensions: dia 143 x 182 mm
AC 240V - 50Hz / 12 V DC adaptor supplied



LED SIXLIGHT

6-channel chaser with integrated microphone

Code : B04538



6 channel chaser
Equipped with 282 LEDs (47 red, 47 green, 94 blue, 47 orange and 47 yellow)
Modular: possibility of changing the shape of the device
Integrated microphone
Adjustable speed and audio sensitivity
Weight: 2.1 Kg
Dimensions: 365 x 347 x 182 mm
AC 240V - 50Hz / 14 V DC adaptor supplied

LASERS



BT-LASER1500 RGB

1.5 W - R:500 mW - G:200 mW - B:800 mW

Code : B04235



Superb 1.5Watt Class IV laser
Incorporates 3 powerful coloured lasers (RVB):
Red laser 500 mW (638 nm)
Green laser 200 mW (532 nm)
Blue laser 800 mW (450 nm)
20Kpps scanners for clean, flawless RGB images!
100% ILDA compatible for maximum flexibility in use!
SD card reader to project your own motifs and logos.
6 user modes
CONTROLLED BY THE MUSIC
MASTER/SLAVE
AUTOMATIC
DMX mode: 1 or 13 channels
ILDA mode
SD CARD mode
Power consumption: 45W max.
Power supply: AC 100/230V - 50/60Hz
Dimensions: 300 x 240 x 160 mm
Net weight: 7.8 kg
Meets EN/IEC 60825-1 Ed2, 2007-03 safety standards with respect to lasers



MULTIBEAM LASER

850 mW - 2xR: 150 mW - G: 50 mW - B: 500 mW

Code : B04236



RGRB White Class 3B 850 mW laser equipped with 4 powerful temperature controlled lasers:
2 150 mW red lasers (650 nm)
1 50 mW green laser (532 nm)
1 500 mW blue laser (450 nm)
4 user modes:
Musical mode: 100% plug&play
MASTER/SLAVE mode
AUTOMATIC mode
DMX mode: 2 or 10 channels
Infrared remote control included
LED display to facilitate navigation in the configuration menu
Power consumption: 65W max.
Power supply: AC 100/230V - 50/60Hz
Dimensions: 537 x 268 x 170 mm
Net weight: 5 kg
Meets EN/IEC 60825-1 Ed2, 2007-03 safety standards with respect to lasers



RADIANT LASER

240 mW - G: 40 mW - B: 200 mW

Code : B04222



Class 3B Laser with one green 40mW 532nm laser and one blue 200mW 450nm laser.
Several modes are available:
DMX mode: 1 or 10 channels
Standalone mode: sound activated (via internal microphone) or automatic mode
Master/Slave mode
Simplified control (CA-8 compatible)
Compatible with RF-DMX Converter:
3-character LED screen for easy navigation through the menus.
Power consumption: 30W max.
Power supply: AC 100/230V - 50/60Hz
Dimensions: 250 x 240 x 190 mm
Net weight: 2.92 kg
Meets EN/IEC 60825-1 Ed2, 2007-03 safety standards with respect to lasers



SPECTRA-3D Laser

480 mW - R:100 mW - G:80 mW - B:300 mW

Code : B04230



RGB Class III 480mW laser
25Kpps scanners combined with 4 effect wheels, Motifs and 3D effect shows, 80 motifs and RGB beams, burst effects... ILDA compatible for maximum use flexibility!
User modes:
MASTER/SLAVE STANDALONE: automatic and sound DMX mode: 1, 2 or 19 channels ILDA mode
Power consumption: 40W max.
Power supply: AC 100/230V - 50/60Hz
Dimensions: 290 x 240 x 110 mm
Net weight: 4.16 kg
Meets EN/IEC 60825-1 Ed2, 2007-03 safety standards with respect to lasers



LOUNGE LASER DMX

190 mW R: 150 mW - G: 40 mW

Code : B04221



190mW laser with one green 40mW laser and one 150mW red laser + blue LED projector with waterwave style!
Several modes are available:
DMX mode: 1 or 7 channels
Standalone mode: sound activated (via internal microphone) or automatic mode
Master/Slave mode
3-digit LED display for simple navigation of the menus
Power consumption: 15W max.
Power supply: AC 100/230V - 50/60Hz
Dimensions: 233 x 165 x 200 mm
Net weight: 1.9 kg
Meets EN/IEC 60825-1 Ed2, 2007-03 safety standards with respect to lasers



SPACE-4 Laser

G: 40mW

Code : B04232



Green 40mW Class 3B compact laser
Several modes are available:
DMX mode: 1 or 8 channels
Standalone mode: sound activated (via internal microphone) or automatic mode
Infrared remote control included
Master/Slave mode
3-digit LED display for simple navigation of the menus
Power consumption: 12W max.
Power supply: AC 100/230V - 50/60Hz
Dimensions: 145 x 160 x 80 mm
Net weight: 1.48 kg
Meets EN/IEC 60825-1 Ed2, 2007-03 safety standards with respect to lasers

LASERS



SMOOTH SCAN-3 Laser

140 mW - G: 100 mW - V: 40 mW

Code : B04226



LASER INTERLOCK SWITCH

Emergency stop mushroom button for Laser

Code : B04210



µ-QUANTUM Laser

180 mW- R: 100 mW - B: 80 mW

Code : B04228



Class 3B Laser based on one green 40mW 532nm laser and one red 100mW 650nm laser.
Fluid movements, 80 motifs, numbers, designs, words, etc....
Several modes are available:
DMX mode: 1 or 17 channels
Standalone mode: sound activated (via internal microphone) or automatic mode
Infrared remote control included
Master/Slave mode
3-digit LED display for simple navigation of the menus
Power consumption: 13W max.
Power supply: AC 100/230V - 50/60Hz
Dimensions: 190 x 170 x 80 mm
Net weight: 1.61 kg
Meets EN/IEC 60825-1 Ed2, 2007-03 safety standards with respect to lasers

This emergency switch is additional safety for your laser projector.

Laser using one red 100mW 650nm laser and one blue 80mW 450nm laser
Plug-and-Play: no controller necessary!
Infrared remote control included
Standalone mode with integrated microphone or automatic shows mode.
Stroboscopic effect available
Adjustable support and AC adaptor included.
Power consumption: 5.7 W max.
Power supply: AC 100/230V - 50/60Hz
Dimensions: 117 x 92 x 46 mm
Net weight: 0.64 kg
Complies with EN/IEC 60825-1 Ed2, 2007-03 standards concerning Laser Safety



µ-PHOTON Laser

120 mW - G: 40 mW - B: 80 mW

Code : B04229



µ-QUASAR Laser

140 mW - G: 40 mW - R: 100 mW

Code : B04225

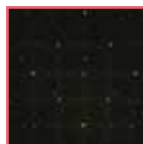

µ-STAR Laser

140 mW -G: 40 mW - R: 100 mW

Code : B04224



Laser using a green 40mW 532nm laser and a blue 80mW 450nm laser
Plug-and-Play: no controller necessary!
Infrared remote control included
Standalone mode with integrated microphone or automatic shows mode.
Stroboscopic effect available
Adjustable support and AC adaptor included.
Power consumption: 5.7 W max.
Power supply: AC 100/230V - 50/60Hz
Dimensions: 117 x 92 x 46 mm
Net weight: 0.64 kg
Complies with EN/IEC 60825-1 Ed2, 2007-03 standards concerning Laser Safety

Laser using one red 100mW 650nm laser and one green 40mW 532nm laser
Plug-and-Play: no controller necessary!
Infrared remote control included
Standalone mode with integrated microphone or automatic shows mode.
Stroboscopic effect available
Adjustable support and AC adaptor included.
Power consumption: 5.7 W max.
Power supply: AC 100/230V - 50/60Hz
Dimensions: 117 x 92 x 46 mm
Net weight: 0.64 kg
Complies with EN/IEC 60825-1 Ed2, 2007-03 standards concerning Laser Safety

Laser using one red 100mW 650nm laser and one green 40mW 532nm laser
Plug-and-Play: no controller necessary!
Infrared remote control included
Standalone mode with integrated microphone or automatic shows mode.
Stroboscopic effect available
Adjustable support and AC adaptor included.
Power consumption: 5.7 W max.
Power supply: AC 100/230V - 50/60Hz
Dimensions: 117 x 92 x 46 mm
Net weight: 0.64 kg
Complies with EN/IEC 60825-1 Ed2, 2007-03 standards concerning Laser Safety



STROBES



BT-GIGAFLASH RGB

Colour LED strobe with 3 separately controllable segments and 1260 RGB strobe LEDs

Code : B04716



BT-GIGAFLASH

Strobe LED with 9 separately controllable segments and a light output of +/- 100 000 lm.

Code : B04714



BT-MAGICFLASH RGB

Colour LED strobe with 3 separately controllable segments and 324 RGB strobe LEDs

Code : B04717



1260 RGB LEDs source
3 independent sections frequency from 0 to 30 Hz and Blinder mode
Flicker free
7 different DMX modes with 1 to 13 channels
LCD display with drop-down menu
Reflector shutters for more rendering
DMX 3 and 5 XLR
Powercon In and Out
Forced and regulated ventilation
Power supply: 240V/50Hz 800 W max
Dimensions: 471 x 195 x 274 mm
Weight: 8.5 kg

1260 4500°K LEDs source
9 independent sections frequency from 0 to 30 Hz and Blinder mode
Flicker free
7 different DMX modes with 1 to 13 channels
LCD display with drop-down menu
Reflector shutters for more rendering
DMX 3 and 5 XLR
Powercon In and Out
Forced and regulated ventilation
Power supply: 240V/50Hz 900 W max
Dimensions: 471 x 195 x 274 mm
Weight: 8.5 kg

324 RGB LEDs source
3 independent sections frequency from 0 to 30 Hz and Blinder mode
Flicker free
7 different DMX modes with 1 to 13 channels
LCD display with drop-down menu
DMX XLR 3
Powercon In and Out
Forced and regulated ventilation
Power supply: 240V/50Hz 140 W max
Dimensions: 336 x 126 x 212 mm
Weight: 4.0 kg



BT-MAGICFLASH

Powerful LED strobe with 9 separately controllable segments and a light output of +/- 35,000 lm.

Code : B04715



BT-STROBE 1500

A powerful 1,500 W professional strobe, 2 DMX channels with intense light output.

Code : B04713



LED MINI FLASH

Strobe, 20x 5mm white led, 1-20 FL/sec

Code : B04706



324 4500°K LEDs source
9 independent sections frequency from 0 to 30 Hz and Blinder mode
Flicker free
7 different DMX modes with 1 to 13 channels
LCD display with drop-down menu
DMX XLR 3
Powercon In and Out
Forced and regulated ventilation
Power supply: 240V/50Hz 250 W max
Dimensions: 336 x 126 x 212 mm
Weight: 4.0 kg

1500W Xenon lamp source
Variable frequency and effects
Adjustment of speed and dimmer by potentiometer
2 DMX channels (speed and dimmer)
DMX XLR 3
Input Jack for CA-8 controller
Power supply: 240V/50Hz
Dimensions: 458 x 147 x 116 mm
Weight: 3.58 kg

20 LEDs of 5mm source
Frequency variable from 0 to 20 Hz
Speed adjustment by potentiometer
Power supply: 240V/50Hz
Dimensions: 110 x 90 x 70 mm
Weight: 0.22 kg

BLACK LIGHT



UV 100W COB LED on individual reflector
 Beam angle: 100°
 DMX IN/OUT by XLR 3
 4-digit display with drop-down menu IR remote control for:
 Dimmer, Strobe, audio mode, Master/ Slave
 Regulated fan cooling
 Power supply: AC 100/240V - 50/60Hz
 Dimensions: 263 x 309 x 300 mm
 Net weight: 4.1 Kg

UV-GUN 100W LED
 UV projector with 100W "COB" LED

Code : B03807



UV-BAR LED

Reliable ultraviolet LED light bar with many advantages over a traditional UV lamp

Code : B03806



12 UV 3W LEDs on individual reflector
 Beam angle: 100°
 DMX IN/OUT by XLR 3
 4-digit display with drop-down menu IN/ OUT power supply via IEC plug
 IR remote control for:
 Dimmer, Strobe, audio mode, Master/ Slave
 Convection cooling without fan
 Power supply: AC 100/240V - 50/60Hz
 Dimensions: 1050 x 93 x 88 mm
 Net weight: 2.7 Kg

MIRROR BALLS



MIRROR BALL 20/50 cm
 Mirror ball 20"/50 cm

Code : B02026



MIRROR BALL 16/40 cm
 Mirror ball 16"/40 cm

Code : B02024



MIRROR BALL 12/30 cm
 Mirror ball 12"/30 cm

Code : B02023



MIRROR BALL 8/20 cm
 Mirror ball 8"/20 cm

Code : B02022



MIRROR BALL 4/10 cm
 Mirror ball 4"/10 cm

Code : B02027



MB ROTATOR Heavy duty
 Motor for mirror balls up to a weight of 10 kg

Code : B04123



MB ROTATOR STANDARD
 Mirror ball motor: 1.5 rpm.

Code : B02021



MB ROTATOR BATTERY
 Motor for mirror balls with a maximum diameter of 20 cm

Code : B02020



CONTROLLERS

Chromateq® offers innovative DMX lighting control solutions (lighting and multimedia) for professional architectural lighting and the entertainment world.

It is a solution adapted to all types of projects and for all sectors of activity: audio system, discos, theatres, concerts, live performances, LED installations, architectural lighting inside and outside, monuments, exhibitions and other services.

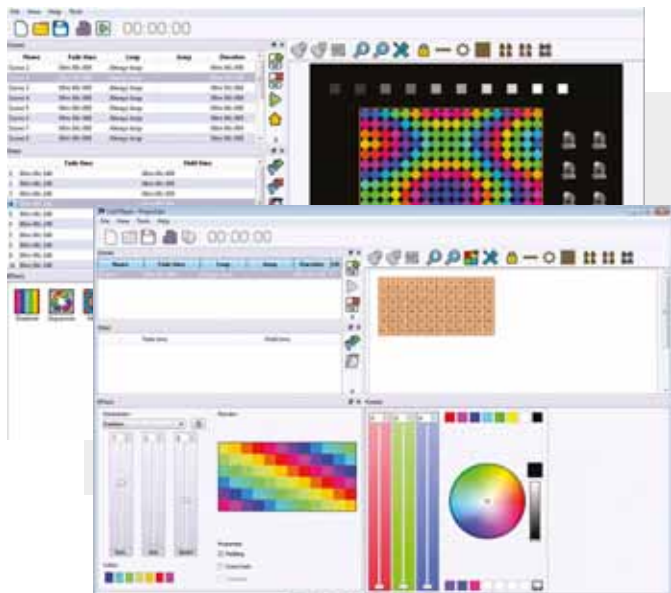

LED PLAYER

Led Player is ideal for all DMX (architectural and entertainment) applications and fixed installations. It can control all standard DMX devices and can record a show in the interfaces. The LED Player is the easiest and most economical solution for DMX lighting control.



LD-512WALL+
DMX wall controller.
For CHROMATEQ software.

Code : B05016



NEW



LD-1024WALL+
DMX Interface 1024ch/4MB, white, Chromateq softw.

Code : B05017





LD-512BOX
512-channel DMX interface with remote control IR
For CHROMATEQ software

Code : B05005



LD-1024BOX
DMX interface with 1024 DMX channels.
For CHROMATEQ software

Code : B05006



Wall interface compatible with "Chromateq Led Player" software (supplied)
512 DMX channels
Internal memory for max. 255 scenes
Activation by external contacts
Access to 10 scenes by buttons
Direct access to the interface:
Trigger, Speed, Dimmer
Calendar function
Merger mode
Operating system: Windows & MAC OSX & Linux
DMX outputs on terminal block
Power supply: By mini USB 5V or DC 9-36 V
Art-Net Universe available: 1

Wall interface compatible with «Chromateq Led Player» software (supplied)
1024 DMX channels
Internal memory for max. 512 scenes
5 programs can run simultaneously
Activation by external contacts
Access to 10 scenes by buttons
Direct access to the interface:
Trigger, Speed, Dimmer
Calendar function
Merger mode
Operating system: Windows & MAC OSX & Linux
DMX outputs on terminal block
Power supply: By mini USB 5V or DC 9-36 V
Art-Net Universe available: 1

Compact DMX interface
Wall interface compatible with "Chromateq Led Player" software (supplied)
IR remote control
512 DMX channels
256 channels in standalone
Internal memory for max. 255 scenes
IR remote control included for:
Choice of scenes, speed, dimmer, BO
Operating system: Windows & MAC OSX & Linux
DMX outputs on XLR connectors
Power supply: By mini USB 5V (cable supplied)
Art-Net Universe available: 1

Standalone compact DMX interface
Compatible with "Chromateq Led Player" and "Chromateq Pro DMX" software. (supplied)
1024 DMX channels (2x512)
132 channels in standalone
Internal memory for max. 255 scenes
IR receiver for optional remote control
Operating system: Windows & MAC OSX & Linux
DMX Inputs and Outputs on XLR and terminal block connectors.
Power supply: By mini USB 5V (cable supplied)
Art-Net Universe available: 2



WI-LIGHT

The application can be used as a WIFI remote control with the LED Player software and LD-512WIFI interface. It can control all Live Board mode and standalone mode controls through a local WIFI connection. For smartphones and tablets.



LD-512EASY+
512-channel DMX interface with 8 buttons.
For CHROMATEQ software.

Code : B05012



LD-1024EASY+
DMX Interface 1024ch/4MB, XLR, Chromateq softw.

Code : B05018



LD-512WIFI
DMX interface with 512 DMX channels.
For CHROMATEQ software and Wi-Light app

Code : B05009



LD-1024DIN
DMX interface 1024 channels in DIN rail format. For CHROMATEQ software

Code : B05013



Compact DMX interface "Chromateq Led Player" and "Chromateq Pro DMX". (supplied)
512 DMX channels
Internal memory for max. 255 scenes
SD card slot for more memory
Activation by external contacts
Access to 80 programs by 8 buttons
Direct access to the interface:
Trigger, Page, Colour, Speed, Dimmer
Calendar function
Splitter mode 2x512
Operating system: Windows & MAC OSX & Linux
DMX outputs on XLR connectors
Power supply: By mini USB 5V or DC 9-36 V
Art-Net Universe available: 1

Compact DMX interface "Chromateq Led Player" and "Chromateq Pro DMX". (supplied)
1024 DMX channels
Internal memory for max. 512 scenes
SD card slot for more memory
Activation by external contacts
Access to 80 programs by 8 buttons
Direct access to the interface:
Trigger, Page, Colour, Speed, Dimmer
Calendar function
Operating system: Windows & MAC OSX & Linux
DMX outputs on XLR connectors
Power supply: By mini USB 5V or DC 9-36 V
5 zones: activate up to 5 programs simultaneously
Art-Net Universe available: 1

Compact DMX interface compatible with Wi-Light application.
Compatible with "Chromateq Led Player" and "Chromateq Pro DMX" software. (supplied)
512 DMX channels
Internal memory for max. 3 x 255 scenes
The application allows you to manage colours, speed and channels.
Activation by external contacts
Calendar function
Operating system: Windows & MAC OSX & Linux
DMX outputs on XLR power connectors:
Supplied with external power supply (9 to 36 V) for use in standalone mode

Interface in DIN rail format
1024 DMX channels
Compatible with "Chromateq Led Player" and "Chromateq Pro DMX" software. (supplied)
Internal 4MB memory for storing programs.
Internal memory for max. 255 scenes
Activation by external contacts or optional remote control
Calendar function
Splitter mode 2x512
Merger mode
Chaining in Master/Slave possible
Operating system: Windows & MAC OSX & Linux
DMX inputs and outputs on connectors.
Power supply: By mini USB 5V or DC 9-36V
Art-Net Universe available: 1



LD-512KIT-IR
Infrared set for CHROMATEQ interfaces

Code : B05011



Infrared set including 2 wireless remotes and 1 IR receiver board that can be installed anywhere in the room. Remote controls can also be used with LD standalone interfaces already integrating an IR receiver.

PRO DMX

Professional software for experienced users and the production of quality shows. Thanks to the Timeline, it is the indispensable controller for Live performances and synchronizations in Audio, Video and lighting. Pro DMX will animate and embellish all your artistic creations easily.

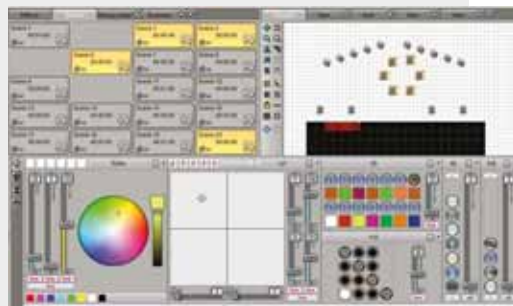

CONTROLLERS

NEW



BT-NODE24
[5pin XLR] - Artnet node: 2x Artnet / 4x DMX in+ou

Code : B05015



GIGABIT Ethernet I/O with internal switch
(link without latency)
ARTNET 4.0 Protocol, sACN
4x I/O DMX fully isolated: configurable as you wish!
MIDI I/O: MIDI control via Ethernet!
Configuration via the WEB interface
RDM compatible
NFC for use with smartphones
Dual redundant power supplies :
230Vac : TRUE-1 cascade sequence
PoE class 2: Power over Ethernet
Allowing to fix 2 units in 1U 19"

NEW



BT-NODE24
[3pin XLR] - Artnet node: 2x Artnet / 4x DMX in+ou

Code : B05014



GIGABIT Ethernet I/O with internal switch
(link without latency)
ARTNET 4.0 Protocol, sACN
4x I/O DMX fully isolated: configurable as you wish!
MIDI I/O: MIDI control via Ethernet!
Configuration via the WEB interface
RDM compatible
NFC for use with smartphones
Dual redundant power supplies :
230Vac : TRUE-1 cascade sequence
PoE class 2: Power over Ethernet
Allowing to fix 2 units in 1U 19"



BT-NODE24

Switch to speed of light



Responsive interface



The perfect all-in-one ArtNet NODE solution with 8 highly configurable XLR 3pin DMX ports.
The 8 DMX ports can all be configured as in or outputs:
Configured as input: normal or backup mode
Configured as output: single, LTP, HTP, RDM or zero mode
You can store all your personal settings and routing options to the different user memories.
Multiple pre-defined routing options available:
4 DMX inputs with 4 local clone outputs DMX and ArtNet output
8 DMX outputs from ArtNet input, with Backup line possibilities
Different merger combinations in both directions:
Combine DMX in + ArNet universe

to Artnet or a physical DMX output (LTP or HTP)
Combine 2 DMX inputs to ArtNet (LTP or HTP)
Multiple mode DMX splitter modes:
One 1 to 7 splitter: 1 DMX input to 7 isolated DMX outputs
Two individual 2 to 3 splitters: each with 1 DMX input to 3 isolated DMX outputs
100% electrical isolation between all in/outputs: problems on 1 port will not influence the other ports.
Easy setup with OLED LCD display
Frame rate of each port can be adapted from 10ms to 40ms to increase compatibility while connecting "slow" DMX-devices to "fast" DMX-controllers.
Fully RDM compatible!



The perfect all-in-one ArtNet NODE solution with 8 highly configurable DMX ports.
The 8 DMX ports can all be configured as in or outputs:
Configured as input: normal or backup mode
Configured as output: single, LTP, HTP, RDM or zero mode
Multiple pre-defined routing options (modes) available:
4 DMX inputs with 4 local clone outputs DMX and ArtNet output
8 DMX outputs from ArtNet input, with "Backup line" possibilities
Different merger combinations in both directions:
Combine DMX in + ArNet universe to Artnet or a physical DMX output (LTP or HTP)
Combine 2 DMX inputs to ArtNet (LTP or HTP)
Multiple mode DMX splitter modes:
One 1 to 7 splitter: 1 DMX input to 7 isolated DMX outputs

Two individual 1 to 3 splitters: each with 1 DMX input to 3 isolated DMX outputs
On top of the pre-defined modes you can also store all your personal settings and routing options to the different user memories.
100% electrical isolation between all in/outputs: problems on 1 port will not influence the other ports.
Easy setup with OLED display
Frame rate of each port can be adapted from 10ms to 40ms to increase compatibility while connecting "slow" DMX-devices to "fast" DMX-controllers.
RDM compatible!
All DMX ports are equipped with 5pin XLR-connectors (3pin XLR-version available)
Two 10/100Mbps Ethernet ports (Neutrik RJ45 Ethercon connectors)
To increase reliability the built-in Ethernet switch has an automatic bypass function to make sure that the network stays fully operational in case of hardware failure.

- Web interface accessible with smartphones via NFC
- 2 Gigabit ports without latency
- PoE
- MIDI I/O



CONTROLLERS

Software available in full French version

Windows
macOS

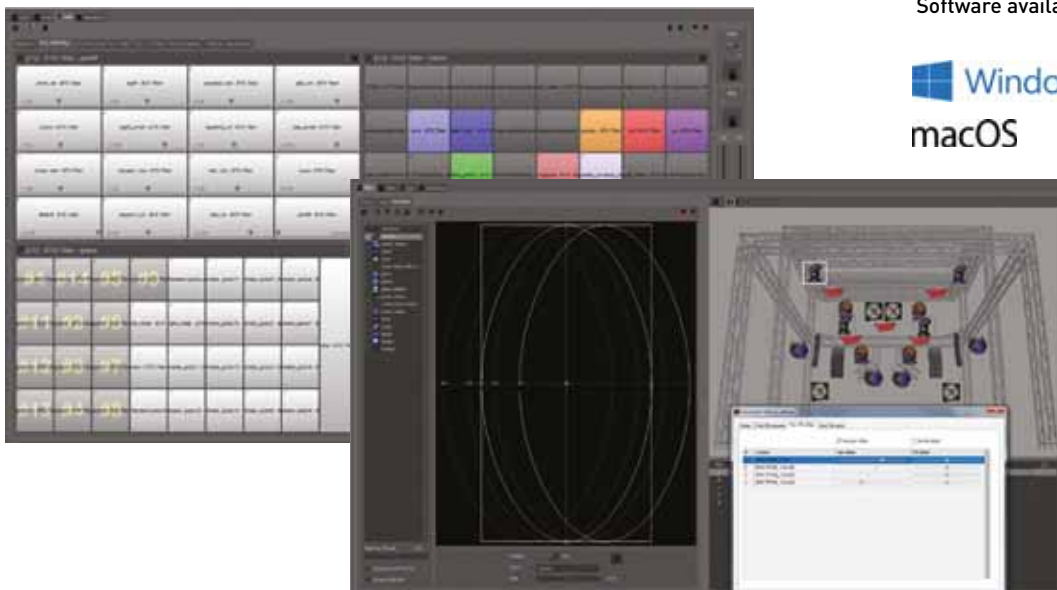

- New version V9
- New skin
- Lightshow creator
- 3DView - New 3D engine
- etc



SWEET D1024
Sweetlight 1024 channel box

Code : H10956

Contest



SWEET D512S
DMX sweetlight 512ch DMX controller

Code : H10957

Contest



SWEET NET512
Ethernet to dmx interface (Sweet light)

Code : H10958

Contest

Compact interface in a metallic box
512 DMX channels - Unlimited number of projectors
Access to 3D and DMX modes simultaneously
Thermal protection
USB powered - USB Cable supplied
Windows and MacOS compatible
Standalone rendering of a 512-channel scene



Lightshow Creator

1 - Lightshow Creator

Declare the fixtures and the groups of fixtures, and select the option « Lightshow Creator » in the main menu. The result is one tab per group of fixtures, with several buttons & pages for all channels, and master faders for dimmer and speed.

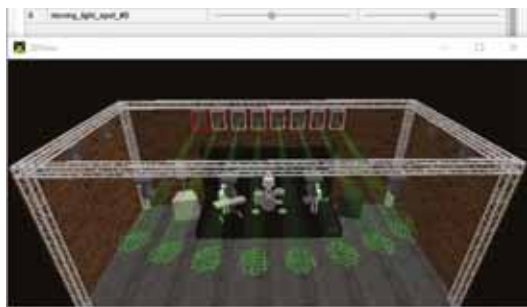

3DView – new 3D engine

2 - 3DView – new 3D engine

3DView is using the application programming interface OpenGL version 3.2+, and it is now able to fully use the GPU of the video cards.

3 - Multi pan/tilt management (from Steps/Generator to 3DView)

Declare the number of the head in the window « Edit fixture ». Manage the pan/tilt channels like with 'single pan/tilt' fixtures.

4 - Live – slider «shift »

For Generator scenes, adjust the shift of a channel for all fixtures, like we do in the tab Generator with the fader « shift ».



Generator – individual pan & tilt offsets & zoom

5 - Generator – individual pan&tilt offsets&zoom

Adjust the position & size of the curve of each fixture, in the window « Generator fixtures settings ».

6 - Generator – fan pan / tilt

Fan the pan or/and tilt of the fixtures, with only two sliders in the window « Generator fixtures settings »,

7 - Live – BPM and Beat

Clear representation and improvements of the functions BPM and Beat.

8 - Live – Virtual DJ

Switch on/off Buttons in Live with VDJ PADS. Get the VDJ music Beats in Live.



	D512S	D1024	NET512
WITH COMPUTER			
operating system	Win/Mac	Win/Mac	Win/Mac
communication	USB	USB	USB
nb dmx channels	512	2 x512	512
Artnet (via computer)	✓	✓	
dmx protection ESD	ESD + GROUND LOOP	ESD + OPTICAL ISOLATIONS	ESD + OPTICAL ISOLATIONS
power	USB POWERED	USB POWERED	9V ADAPTOR (SUPPLIED)
STAND-ALONE MODE			
nb dmx channels	512	512	512
nb (dynamic) scenes	1	1	9
nb zones	1	4	4
web server			✓
ethernet message			✓
calendar			✓

CONTROLLERS



MEMORY-24

24-channel DMX console for power blocks

Code : H9067



Organ playing with 2 courses of 12 circuits or 1 course of 24 circuits
4,600 memories and 48 programmable sequences
Crossfade
Adjustable speed and rise time of sequences
Backup memories internally
Possibility of mixing several sequences
Sound mode
Manual triggering by Tap synchro
Triggering scenes and sequences in MIDI
DMX 512 output on 3-pin XLR plug
External power supply (DC 9 V - 12 V, 500 mA)
Dimensions: 483 x 265 x 90mm
Weight: 4.6 kg



PILOT-192PRO

192-channel DMX controller with joystick

Code : H9073



192 channels (12 projectors of 16 channels)
30 banks of 8 programs each
12 chases (240 steps per chase)
Pan/Tilt
Fade Time
MIDI control of memories and blackout
Assignable joystick for Pan/Tilt movements
Connection for foot control and smoke machine
Sound mode
Dimensions: 483 x 82 x 135 m
Weight: 2.2 kg



SCM-1 SCENEMASTER

16 DMX channels with MIDI output

Code : B04624



64 channels (4 projectors of 16 channels)
16 scenes of 16 channels
MIDI control of faders and flashes
Midi In controls scenes with compatible software
16 buttons for flashes or scenes
Dimensions: 483 x 85 x 133 m
Weight: 2.5 kg



LEDCON-XL

LEDCON-XL controller

Code : B04661



64 channels (8 projectors with 8 channels each) patchable
Control of colours, fades and chases.
8 faders for other functions
4- or 8-channel modulators with speed control or sound mode
Choice of RGB, white RGB, amber white RGB modes, etc.
UV button for 6-in-1 LED projectors that include a UV LED.
Separate control for strobe and dimmer.
Instant access to 9 preprogrammed colour chasers
Static or audio chaser mode 32-colour spectral blend.
Dimensions: 483 x 75 x 133 m
Weight: 2.2 kg



CONTROLLER CASE 3U

Compact flight case for all kinds of small 19" controllers

Code : B03224



Compact flight case for controllers
19" up to 3U
Accessory compartment
Rubber feet





PILOT-8

Programmable 8x8 channels controller

Code : H10126



64 patchable channels (8 projectors with 8 channels each)
 8 colours recorded and 24 free
 8 pre-programmed colours and 24 free
 Assignable patch for RGBWA and dimmer functions
 2 assignable free channels
 Strobe function
 Adjustable sequence speed
 Connectors:
 - DMX output on XLR
 - RJ45 for DMX control of the Contest Architecture range using the PILOT
 - Jack for external controller Easy-2 for launching programs, choice of colours and Blackout
 - USB for the night light supplied
 Dimensions: 400 x 200 x 68 mm
 Weight: 2.3 kg



MANU-6X

DMX 6 channels + master controller

Code : H9064



6-channel DMX console
 6 faders + Master
 Operates on 9 V battery
 Supplied AC adapter
 Ideal for the control of architectural colour changers
 DMX output: 3-pin XLR
 Dimensions: 173 x 153 x 55 mm
 Weight: 0.8 kg



PARCONTROL34

RGB and RGBW compatible DMX controller

Code : H9913



Control of colour, prog, strobe.
 Direct access to 12 colours and 3 shades of whites
 RGBW colour graduation
 Audio mode
 Strobe speed
 2 control modes
 Mode 1: R,G,B, Dim/Strobe, White
 Mode 2: R,G,B,White
 Power supply: DC 9-12V 300mA
 Dimensions: 270 x 170 x 60 mm
 Weight: 1.1 Kg



PARCONTROL

DMX controller for RGB projector

Code : H9406



Control of colour, prog, strobe.
 Direct access to 9 colours
 RGB colour graduation
 Audio mode
 Strobe speed
 Fixed patch R, G, B, Dimmer/Strobe.
 Power supply: DC 9-12V 300mA
 Dimensions: 220 x 140 x 36 mm
 Weight: 1 Kg



LEDCON-02 Mk2

Small pre-programmed LED controller

Code : B04660



Control of colour, prog, strobe.
 Direct access to 9 colours
 Faders for chasers, speed and Dimmer
 Audio mode
 Fixed patch R,G,B, Dimmer/Strobe
 Works in 4 or 8 channel mode
 Power supply: DC 9-12V 300mA
 Dimensions: 210 x 140 x 46 mm
 Weight: 1 Kg



PARPILOT

DMX control box for PAR LEDs CONTEST and LED4STAGE

Code : H9658



Control of colour, prog, strobe.
 2 control modes: Fixed colour and running light
 Fixed patch R,G,B, Dimmer/Strobe
 Works in 4 or 16 DMX channels
 10 pre-memorized internal programs
 Musical Mode, Tap Tempo and Colour Variation
 Quick access to 8 fixed colours
 Management of scroll speed and intensity
 Strobe effect
 Net or progressive colour chaining
 Blackout
 Power supply: DC 12 V 100 mA (supplied)
 Dimensions: 70 x 110 x 33 mm
 Weight: 0.31 kg

CONTROLLERS



CA-8

Remote compatible with most lighting effects

Code : B04192



Colour/gobo control of programs and of Blackout.
Connectivity: 6.35 stereo jack
Cable length: 11 m



EASY-2

Universal remote control for Contest devices

Code : H8701



Colour/gobo control of programs and of Blackout.
Connectivity: 6.35 stereo jack
Cable length: 11 m



BT-STR4

4-channel controller for strobes.

Code : B04712



Strobe controller
Analog outputs and DMX (2-channel)
Manual or automatic operation 10 different programs
Single flash, Full on / Blinder, Blackout
Adjustable speed
Dimmer (only in DMX)
Audio mode
Compatible with analog strobes using 12V DC pulses such as: MEGA STROBE 1500, ...
Compatible with DMX strobes using 2 channels such as: MEGA STROBE 1500 DMX, BT-STROBE 3000, ...



DMS-26

The perfect all-in-one solution for securing your DMX installations: MERGER + SPLITTER + BOOSTER.

Code : B04625



SPLITTER:
100% electrical insulation
2 inputs and 6 DMX outputs
BOOSTER:
signal reconstruction
MERGER:
Mixer:
HTP: Priority to the highest value
Backup: if signal A is faulty then relay on signal B
Priority channel address per input.
DMX speed 23 ms to 45 ms.
Signal loss setting:
Null , Hold , Clear
4-character LED display.
Dimensions: 482 x150 x 44 mm
Weight: 2.9 kg



DS 12

PRO splitter DMX+IEC 1in/2out

Code : B04631



SPLITTER:
100% electrical insulation
1 input and 2 DMX outputs
BOOSTER:
signal reconstruction
Bidirectional RDM compatible
Inputs:
DMX 3 and 5 XLR
IEC 10A
Outputs:
2 DMX XLR3
2 IEC 10A
Dimensions: 130 x132 x 56 mm
Weight: 0.95 kg



SPLIT-2

DMX line splitter of 1 input 2 outputs

Code : H7546



SPLITTER:
100% electrical insulation
1 input and 2 DMX outputs
BOOSTER:
signal reconstruction
Inputs:
DMX 3 and 5 XLR
Outputs:
2 DMX 3 and 5 XLR
Overvoltage protection on each channel by fuse: 500 mA - 250 V
Signal presence indicators
Dimensions: 245 x 165 x 72 mm
Weight: 1.9 kg



MINI DMX-SPLITTER
Mini DMX splitter 1in/2out

Code : B04630



SPLITTER:
100% electrical insulation
1 input and 2 DMX outputs
BOOSTER:
signal reconstruction
Inputs:
DMX XLR 3
Outputs:
2 DMX XLR3
Dimensions: 102 x 72 x 40 mm
Weight: 0.24 kg



airBOX-ER1
Wireless DMX transmitter and receiver box of 512 DMX channels and 7 WiFi frequencies

Code : H9966



Transceiver operation in automatic transmitter and receiver
- ISM 2.400-2.483GHz frequency band
Channel selection button with tricolour LED
Choice of 7 different channels to make groups of projectors
Power supply:
- AC 100/240 V - 50/60 Hz
Input and output power
DMX input and output on XLR3
Maximum transmission power: 20 dBm/100 mW
Removable bracket for hanging on structures and wall attachment
Dimensions: 165 x 120 x 53 mm
Net weight: 0.5 kg



M-DMX TRANSCEIVER
Wireless DMX! Compatible with WTR-DMX DONGLE.

Code : B04646



Transceiver can operate in transmitter or receiver mode
- 2.4 GHz frequency band
Compatible with the "Wireless Solution" W-DMX™ Protocol
Works perfectly with Briteq WR-DMXG4 (4632) in WT-DMXG4 (4633)
5V DC power supply via micro USB or adapter included
DMX input and output on XLR3
Dimensions: 103 x 76 x 36 mm
Net weight: 0.250 kg



WTR-DMX DONGLE
The perfect solution for anyone looking for an extremely reliable wireless DMX!

Code : B04645



Transceiver can operate in transmitter or receiver mode
- 2.4 GHz frequency band
Compatible with the "Wireless Solution" W-DMX™ Protocol
Works perfectly with Briteq WR-DMXG4 (4632) in WT-DMXG4 (4633)
5V DC power supply via USB port
DMX connection via USB port
Dimensions: 71 x 42 x 11 mm
Net weight: 0.02 kg



FIRMWARE UPDATER
This device allows you to do firmware updates on DMX projectors and light effects.

Code : B04319



Firmware update box for compatible devices.
Works with the software that allows you to load the program via the USB port.
Possible to update multiple devices in one time.
Check the compatibility of your device.



FIRMWARE UPDATER 2
Standalone programmer that makes it easy to update the firmware of projectors on site.

Code : B04379



Firmware update box for compatible devices. The update is loaded on the micro-SD card
Possible to update multiple devices in one time.
Possible to store firmware files for different projectors.
Charging the internal battery via a mini USB input.
Output: 3-pin XLR
USB stick adapter/micro-SD card
Supplied with mini USB cable and micro-SD card
Check the compatibility of your device.



FIRMWARE UPDATER 3
Firmware update cable

Code : B04389



Firmware update cable for compatible devices.
Works with the software that allows you to load the program via the USB port.
Possible to update multiple devices in one time.
Check the compatibility of your device.



DMS-26

The perfect all-in-one solution to secure your installations.

ELECTRICAL DISTRIBUTION



DIM-6X16

6x16A DMX 6-channel block with faders

Code : H9058



BT-626/FRA

6-channel professional Dimmer/Switch pack for rack mounting 19".

Code : B04634



BT-626/GER

6-channel professional Dimmer/Switch pack for rack mounting 19".

Code : B04635



Power rating: 16 A (3500 W) per channel / 96 A max. resistive/inductive
Protection of each channel by bipolar circuit breaker
LEDs indicating charge presence on each channel
DMX addressing Dip Switch
6 linear potentiometers for manual dimming
Power supply: single-phase or three-phase on internal terminal blocks (230 V - 50 Hz)
6 16A French plug outputs on the back
DMX input and output: on 3-pin XLR connectors
Dimensions: 482 x 390 x 90
Weight: 7 kg

Power rating: 16 A (3500 W) per channel / 96 A max. resistive/inductive
Protection of each channel by circuit breaker
LEDs indicating charge presence on each channel
Independent addressing of each channel
6 linear potentiometers for manual dimming
Preheat control of lamps from 0 to 6%
LED display to monitor all functions, including internal temperature
Power supply: single-phase or three-phase on terminal blocks (230 V - 50 Hz)
6 16A French plug outputs on the back
DMX XLR 3 and RJ11 input and output
0/10V input on DB9
Dimensions: 482 x 312 x 90
Weight: 8 kg

Same as BT-626/FRA but with outputs on 6 standard German plugs.



DSP-4 Mk2 /F

Multifunctional dimmer/switch pack with 4 sockets (French Schuko).

Code : B04643



DSP-4 Mk2 /G

Multifunctional dimmer/switch pack with 4 sockets (German Schuko).

Code : B04644



Power rating: 8 A (1850 W) per channel / 15 A max. resistive/inductive
Protection of each channel by fuse
Independent addressing of each channel
LED display with drop-down menu
Power supply: 240V - 50Hz single phase
4 16A French plug outputs on the front
DMX XLR 3 input and output
Dimensions: 482 x 100 x 88
Weight: 2.9 kg

identical to the DSP-4 MK2 but with outputs on 4 standard German plugs.



DIM-1X10

1-channel 1x10A DMX block with PC output fader

Code : H9061



Power rating: 10 A (2200W) resistive/ inductive
 Linear potentiometers for manual dimming
 Cable length of the remote fader: 1.8 m
 LED display with drop-down menu
 DMX input/output on 3-pin XLR plugs
 Output on French plug
 Power supply: AC 230 V, 50 / 60 hz
 Dimensions: 150 x 125 x 82 mm
 Weight: 1.5 kg



DIM-4X5

4-channel 4 x 5A compact DMX block with faders

Code : H9057



Power rating: 5 A (1100 W) per channel / 16 A max. resistive/inductive
 16 internal chase programs with variable speed
 Individual fader per channel, with speed adjustment
 4 DMX channels with independent assignment in DMX 512
 Modes: Master/slave, program, DMX, sound via build-in microphone.
 Switch/dimmer pack
 Control of 4 DMX channels via faders
 Outputs on 4 French mains plugs
 Power supply: AC 120 V / 230 V - 50 / 60 Hz, 16 A maximum
 Dimensions: 250 x 208 x 68 mm
 Weight: 2.5 kg



RG8USB

1U rackable strip, 8 European plugs + 2xUSB

Code : H10840



1U rackable 19" strip with:
 8 sockets on the back
 2 USB ports (1A) on the front
 1 bipolar switch on the front panel to control the outlets
 Standard German plugs with child protection
 3G1.5mm² cable - length 2m
 Dimensions: 483 x 46 x 90 mm
 Power supply: 230V - 50 Hz
 Weight: 1 kg



PC-8 Mk2 FRA/BEL

8-channel dispatch with bipolar switches

Code : B02049



Outputs on 8 IP54 outlets
 Standard French plugs
 8 bipolar switches
 6.3 amp fuse for each channel
 the total charge cannot exceed 15 amps (3300 W)
 Rackable 19 inches / 2U
 Dimensions: 483 x 80 x 97 mm
 Power supply: 230V - 50 Hz
 Weight: 2 kg



PC-8 Mk2 GER

8-channel dispatch with bipolar switches

Code : B02059



Outputs on 8 IP54 outlets
 Standard German plugs
 8 bipolar switches
 6.3 amp fuse for each channel
 the total charge cannot exceed 15 amps (3300 W)
 Rackable 19 inches / 2U
 Dimensions: 483 x 80 x 97 mm
 Power supply: 230V - 50 Hz
 Weight: 2 kg



RG2x8

1U double-sided rackable strip, 2x8 European plugs

Code : H10837



1U rackable 19" strip with:
 8 sockets in front / 16A protection
 8 sockets at the rear / 16A protection
 2 front bipolar switches to control front outlets and rear outlets
 Standard German plugs with child protection
 3G1.5mm² cable - length 2m
 Dimensions: 483 x 46 x 90 mm
 Power supply: 230V - 50 Hz
 Weight: 1.33 kg

ELECTRICAL DISTRIBUTION



PD-63SH/FRA-BEL

Distributor 63A Tetra / 12x16A Mono + 2x 16PIN + 2x19PIN + 1 CEE 63A output.

Code : B04647



1 x 63A 4-pole circuit breaker (3P+N) for protection of all outputs, including 63A output
 1 x 30 mA 63A differential circuit breaker for the protection of persons
 12 x bipolar circuit breakers for 12 16A standard French outlets (4 outlets per phase)
 V-meters + A-meters per phase
 1.5 m mains input cable with CEE 63A plug
 1 x CEE 63A output connector
 2 x 16-pin harting type connector
 2 x 19 pin socapex type connector
 Dimensions: 482 x 266 x 326 mm
 Rackable 19" height 6U
 Power supply: 400V - 50 Hz (3P+N+E)
 Weight: 11.74 kg



PD-63SH/GERMAN

Distributor 63A Tetra / 12x16A Mono + 2x 16PIN + 2x19PIN + 1 CEE 63A output.

Code : B04648



1 x 63A 4-pole circuit breaker (3P+N) for protection of all outputs, including 63A output
 1 x 30 mA 63A differential circuit breaker for the protection of persons
 12 x bipolar circuit breakers for 12 16A standard German outlets (4 outlets per phase)
 V-meters + A-meters per phase
 1.5 m mains input cable with CEE 63A plug
 1 x CEE 63A output connector
 2 x 16-pin harting type connector
 2 x 19 pin socapex type connector
 Dimensions: 482 x 266 x 326 mm
 Rackable 19" height 6U
 Power supply: 400V - 50 Hz (3P+N+E)
 Weight: 11.74 kg



PD-63A Mk2/FRA-BEL

Distributor 63A Tetra / 2 x outputs CEE 32A + 3 x 16A Mono.

Code : B04639



1 x 30 mA 63A differential circuit breaker for the protection of persons
 2 x 32A 4-pole circuit breakers (3P+N) for the protection of two P17 32A outputs
 3 x bipolar circuit breakers for 3 16A standard French outlets (1 outlet per phase)
 V-meters + A-meters per phase
 1.5 m mains input cable with CEE 63A plug
 2 x CEE 32A output connectors
 Dimensions: 482 x 274 x 152 mm
 Rackable 19" height 3U
 Power supply: 400V - 50 Hz (3P+N+E)
 Weight: 11.74 kg



PD-63A Mk2/GER-NL

Distributor 63A Tetra / 2 x outputs CEE 32A + 3 x 16A Mono.

Code : B04640



1 x 30 mA 63A differential circuit breaker for the protection of persons
 2 x 32A 4-pole circuit breakers (3P+N) for the protection of two P17 32A outputs
 3 x bipolar circuit breakers for 3 16A standard German outlets (1 outlet per phase)
 V-meters + A-meters per phase
 1.5 m mains input cable with CEE 63A plug
 2 x CEE 32A output connectors
 Dimensions: 482 x 274 x 152 mm
 Rackable 19" height 3U
 Power supply: 400V - 50 Hz (3P+N+E)
 Weight: 11.74 kg



PD-32SH/FRA-BEL

Distributor 32A Tetra / 6 x 16A Mono + 1 x 16PIN + 1x19PIN + 1 x CEE 32A output.

Code : B04636



1 x 30 mA 32A differential circuit breaker for the protection of people
 1 x 32A 4-pole circuit breaker (3P+N) for protection of all outputs, including the 32A output
 6 x bipolar circuit breakers for 6 16A standard French outlets (2 outlets per phase)
 V-meters + A-meters per phase
 1.5 m mains input cable with CEE 32A plug
 1 x CEE 32A output connector
 2 x 16-pin harting type connector
 2 x 19 pin socapex type connector
 Dimensions: 482 x 258 x 152 mm
 Rackable 19" height 3U
 Power supply: 400V - 50 Hz (3P+N+E)
 Weight: 8.78 kg



PD-32SH/GERMAN

Distributor 32A Tetra / 6 x 16A Mono + 1 x 16PIN + 1x19PIN + 1 x CEE 32A output.

Code : B04637



1 x 30 mA 32A differential circuit breaker for the protection of people
 1 x 32A 4-pole circuit breaker (3P+N) for protection of all outputs, including the 32A output
 6 x bipolar circuit breakers for 6 16A standard German outlets (2 outlets per phase)
 V-meters + A-meters per phase
 1.5 m mains input cable with CEE 32A plug
 1 x CEE 32A output connector
 2 x 16-pin harting type connector
 2 x 19 pin socapex type connector
 Dimensions: 482 x 258 x 152 mm
 Rackable 19" height 3U
 Power supply: 400V - 50 Hz (3P+N+E)
 Weight: 8.78 kg



BREAK-3X16

3x16A power supply block on 6 outlets with vu-meter

Code : H9059



3 x bipolar circuit breakers for 6 16A standard French outlets (2 outlet per phase)
 V-meters + A-meters per phase
 1 x CEE 16A input connector
 1 x 16A socket in front on phase 1
 Dimensions: 482 x 260 x 152 mm
 Rackable 19" height 2U
 Power supply: 400V - 50 Hz (3P+N+E)
 Weight: 3.8 kg



ELECTRICAL DISTRIBUTION



DIST3x2F

TRI 1xC EE16A distributor - 3x2 French outlets

Code : H10838



Rackable distributor 19" height 1U
Power input cable in 5G1.5mm² with a length of 2 m + Tetra CEE 16A plug
6 16A standard French sockets on the front (2 outlets per phase)
Weight: 1.1 Kg



DIST3x2E

TRI 1xC EE16A distributor - 3x2 European outlets

Code : H10839



Rackable distributor 19" height 1U
Power input cable in 5G1.5mm² with a length of 2 m + Tetra CEE 16A plug
6 16A standard German sockets on the front (2 outlets per phase)
Weight: 1.1 Kg

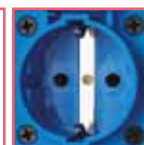

DIST-CUBE

Tri 1xC EE16A distributor / 3 x European outlets

Code : H10868



Cube format distributor
2 M10inserts
Tetra CEE 16A input plug
3 16A standard German plugs (1 outlet per phase)
Dimensions: 160 x 136 x 102 mm
Weight: 0.86 Kg



LIFTING CONTROL



RICO-V8

8-channel chain lift motor controllers with separate UP / DOWN buttons and master / slave function.

Code : B07000



Standalone controller for chain lift motors. Control up to 8 motors independently. Compatible with the RICO-V4 model. Multiple units can be connected as master/slave. Simultaneous control of the hoists using the UP/DOWN buttons on the master controller. Emergency stop. "Slave" LED indicator light. Manual phase inversion switch for each output. Choice of different outputs: 4 16 A outputs, 4 individual CEE poles. 2x 16-pin connectors, Harting® type. 2x 19-pin connectors, Socapex® type. 1x PowerCON 16 A power outlet. XLR input for the remote control [RICO-REMOTE] (optional). Phase indicators available. A 4-pole 32A circuit breaker protects ALL outlets, including the 32A output to the next unit in the chain. In case of emergency, all the phases AND the neutral are disconnected. 2x C16 bipolar automatic circuit breakers (16 A - 1P+N) for the protection of circuits + auxiliary output. AC input cable (3 x 32 A, 5 wires), equipped with CEE 32 A input socket (3P+N+T). Output connector bypass (3 x 32 A, 5 wires) of EEC type (3P+N+T) (19 inches)/4 U rugged metallic box. Designed and manufactured in Europe. Dimensions: 482 x 184 x 430 mm. Power supply: 400V - 50 Hz (3P+N+E). Weight: 13.5 kg.



RICO-V4

4-channel chain lift motor controllers with separate UP / DOWN buttons and master / slave function.

Code : B04649



Standalone controller for chain lift motors. Control up to 4 motors independently. Multiple units can be connected as master/slave. Simultaneous control of the hoists using the UP/DOWN buttons on the master controller. Emergency stop. "Slave" LED indicator light. Manual phase inversion switch for each output. Choice of different outputs: 4 16 A outputs, 4 individual CEE poles. 1x 16-pin connectors, Harting® type. 1x 19-pin connectors, Socapex® type. 1x PowerCON 16 A power outlet. XLR input for the remote control [RICO-REMOTE] (optional). Phase indicators available. A 4-pole 32A circuit breaker protects ALL outlets, including the 32A output to the next unit in the chain. In case of emergency, all the phases AND the neutral are disconnected. 2x C16 bipolar automatic circuit breakers (16 A - 1P+N) for the protection of circuits + auxiliary output. AC input cable (3 x 32 A, 5 wires), equipped with CEE 32 A input socket (3P+N+T). Output connector bypass (3 x 32 A, 5 wires) of EEC type (3P+N+T) (19 inches)/4 U rugged metallic box. Designed and manufactured in Europe. Dimensions: 482 x 184 x 430 mm. Power supply: 400V - 50 Hz (3P+N+E). Weight: 13.5 kg.



RICO-REMOTE

Remote control for RICO-V4 and RICO-V8

Code : B04650



Equipped with:
2 UP / DOWN buttons
1 backlit emergency stop button
1 6.5m cable (XLR 5pin male / female)

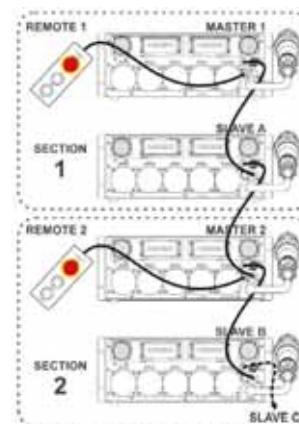



EFFECT MACHINES

SMOKE, FOG, BUBBLE AND SNOW
MACHINES
PERFUMES AND LIQUIDS



EFFECT MACHINES



BT-H2FOG

Low Fog machine without restriction

1500W Low Fog machine in flightcase producing heavy smoke thanks to ultrasonic technology that is much less restrictive than dry ice and just as efficient.

Easy to use: it only needs tap water (demineralized water is recommended) and smoke liquid.

The «Click-on» system allows quick assembly and disassembly of the diffuser.

NEW

BT-H2FOG
Machine fumée lourde à ultrasons

Code : B04898

Mains Input: AC 220-240V, 50/60Hz
Power consumption: 1750 W
DMX Channels: 2
Fuse: 10A
Warm up time: 3.5 min
Fog liquid tank: 2.5L
Max output: +/- 11000 cfm
Water tank: +/- 10 liters
Fog liquid consumption: 1-40 ml/min
Recommended Fluid: Standard fog fluid
Dimensions (L x W x H): 750 x 445 x 550 mm
Weight: 39 kg

NEW

HZ-1000
Machine à brouillard

Code : B04861

The maximum haze output is HZ-500's double.
Two operational modes: Single-Compressor or Twin-Compressor mode can be selected to create needed haze volume.
Equipped with TFT color Touch Panel provides simple control interface.
Flight case with wheels gives better protections for tours.
Internal turbo fan enables haze to go higher and farther; Wind diverter can be set to 3 different angles.
Dry haze with minimum residues.
6.4-liter large reservoir allows long time operation without frequent refills.
Clear liquid level indication window.
Operating time : 40 hrs max. output



F-7 Smaze
All-in-one solution: fog and mist modes

Code : B04844

Tank: 5 litres
Preheating time: 8 minutes
Output volume:
Fog mode: 650 m3 per minute
Faze mode: 170 m3 per minute
Max. consumption
Fog mode: 140 ml/min
Faze mode: 28 ml/min
Control panel: LCD screen, smoke volume and diffusion fan speed management
DMX mode: 3 channels
Integrated DMX wireless receiver:
Use liquid:
Power supply: 230V - 50Hz
Power consumption: 1650W max.
Dimensions: 710 x 412 x 710 mm
Net weight: 52,5 Kg





HZ-500

Hazer machine

Code : B04817



HZ-350

Hazer machine

Code : B04826

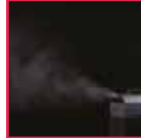

F-5D

Fazer machine trustworthy and efficient.

Code : B04846

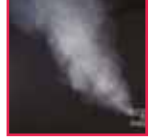

Tank: 2.5 litres
 Output volume: 85 m3 per minute
 Max. consumption: 1.1ml/min
 Control panel: LCD display
 Volume and Timer Mode
 DMX mode: 1 channel
 Noise level: lower than 70 dB from 10cm
 Use hazer liquid HZL-5
 Power supply: 230V - 50Hz
 Power consumption: 480W max.
 Dimensions: 490 x 351 x 338 mm
 Net weight: 31.5 Kg

Tank: 2.5 litres
 Output volume: 57 m3 per minute
 Max. consumption: 0.8 ml/min
 Control panel: LCD display
 Volume and Timer Mode
 DMX mode: 1 channel
 Wireless remote included
 Use hazer liquid HZL-5
 Power supply: 230V - 50Hz
 Power consumption: 390 W max.
 Dimensions: 492 x 273 x 314.5 mm
 Net weight: 14.2 Kg

Heating element: 800W
 Preheating time: 4 minutes
 Tank: 2.8 litres
 Output volume: 85 m3 per minute
 Max. consumption 3ml/min at 100%
 Control panel: LCD screen, smoke volume and diffusion fan speed management
 DMX mode: 2 channels
 Integrated DMX wireless receiver:
 Use liquid:
 Power supply: 230V - 50Hz
 Power consumption: 800W max.
 Dimensions: 535 x 465 x 225 mm
 Net weight: 22.9 Kg



HAZETEC

Smoke / Fazer machine

Code : H10487



FLY-HAZETEC

Flight case for HAZETEC

Code : H10510



BT-FAZE 7500

Machine à brouillard 1200W - 7500cuft DMX Prof.

Code : B04851



Heating element: 1400W (preheating), 90W (operation)
 Preheating time: 46 seconds
 Tank: 6 litres
 Output volume: 99m3 per minute
 Max. consumption 17ml/min at 100%
 Control panel with smoke volume and diffusion fan speed management
 2 DMX channels: Smoke volume and diffusion fan speed
 Use liquid:
 Power supply: 230V - 50Hz
 Power consumption: 900W max.
 Dimensions: 343 x 364 x 290 mm
 Net weight: 11.9 Kg

Mains Input: AC 230V, 50Hz
 Power consumption: 1200 Watt
 DMX Channels: 2
 Fuse: T8A/250V (slow blow 6x30mm)
 Output: +/- 7500 cubic ft/min (200m3)
 Warm up time: 2.5 min
 Tank size: 5L
 Recommended Fluid: Antari FLG-5
 Size: 490x225x330mm
 Weight: 12kg

EFFECT MACHINES



Z-380

Hazer machine

Code : B04847



Z-350

Fazer

Code : B04828



FAZE-700

Fazer

Code : B04891



Heating element: 1500W
 Preheating time: 1.5 minutes
 Tank: 1.2 litres
 Output volume: 170m3/min
 Max. consumption: 6 ml/min at 100%
 Control panel with smoke volume and fan management
 DMX mode: 1 or 2 channels
 Use liquid:
 Power supply: 230V - 50Hz
 Power consumption: 1500W
 Dimensions: 328 x 248 x 265 mm
 Net weight: 8.48 kg

Heating element: 700W
 Preheating time: 4 minutes
 Tank: 1.3 litres
 Output volume: 85m3/min
 Max. consumption: 3ml/min at 100%
 Control panel with smoke volume and fan management
 2 DMX channels: Smoke/fan
 Use liquid:
 Power supply: 230V - 50Hz
 Power consumption: 900W max.
 Dimensions: 320 x 153 x 391 mm
 Net weight: 8.8 kg

Heating element: 700W
 Preheating time: 3 minutes
 Tank: 1.2 litres
 Output volume: 39.65 m3/min
 Adjustable fog output:
 Via the integrated control panel.
 Via wired remote (included).
 Use liquid: FOG LIQUID HI-TECH or FOG LIQUID STD
 Power supply: 230V - 50Hz
 Power consumption: 700W
 Dimensions: 300 x 147 x 290 mm
 Net weight: 5 kg



Z-3

ANTARI wired remote Z-350

Code : B04829



CTL-FazeTec

Remote Volume/On/Off for FazeTEC

Code : H10246



Wired remote for Z-350
 Connector: stereo jack 6.35 mm
 Function: Volume, start/stop

Wired remote for FazeTEC
 Connector: stereo jack 6.35 mm
 Function: Volume, start/stop



FT-200

Smoke machine - 1600 W designed for fire training

Code : B04881



FT-100

Smoke machine - 1500 W designed for fire training

Code : B04880



FT-20

Portable smoke machine 600 W on batteries designed for fire training

Code : B04882



Heating element: 1600W
 Preheating time: 7 minutes
 Tank: 2.4 litres
 Max. consumption 270 ml/min at 100%
 Coverage: Height 8 metres
 Control panel: LCD display
 Volume and Timer Mode
 DMX mode: 1 channel
 Wireless W-2 remote included
 Z-3 remote optional
 Use liquid FLP-6
 Power supply: 230V - 50Hz
 Power consumption: 1600 W max.
 Dimensions: 301 x 194 x 414 mm
 Net weight: 16 Kg

Heating element: 1500W
 Preheating time: 7.5 minutes
 Tank: 6 litres
 Max. consumption 100 ml/min at 100%
 Output volume: 560 m3 per minute
 Control panel: LCD display
 Volume and Timer Mode
 DMX mode: 1 channel
 Wireless W-2 remote included
 Z-3 remote optional
 Use liquid FLP-6
 Power supply: 230V - 50Hz
 Power consumption: 1500 W max.
 Dimensions: 580 x 278 x 264 mm
 Net weight: 14.6 Kg

Heating element: 600W
 Battery: DC 12V
 Preheating time: 1 sec
 Tank: 0.4 litres
 Max. consumption 16 ml/min at 100%
 Control panel:
 Manual: on/off
 DMX mode: 1 channel
 WTR-20 optional
 Z-3 remote optional
 Use liquid FLP-6
 Charger: AC 230V - 50Hz / DC 12V
 Power consumption: 600 W max.
 Dimensions: 580 x 278 x 264 mm
 Net weight: 14.6 Kg



FT-20SE

Base de puissance pour machine à fumée FT-20

Code : B04884



EFFECT MACHINES



WTR-20

Wireless transmitter and receiver 433MHz

Code : B04883



1 x W-2 transmitter
1 x W-2 receiver
frequencies: 315MHz and 433MHz



W-515D

Smoke machine 1500W

Code : B04842



Heating element: 1500W
Preheating time: 10 minutes
Tank: 6 litres
Output volume: 566 m3/min
Max. consumption: 10 min/litre at 100%
Wireless remote included
Control panel: LCD display
Management: Volume, Timer
DMX mode: 1 channel
Integrated DMX wireless receiver
Use liquid: FLG-5
Power supply: 230V - 50Hz
Power consumption: 1500W max.
Dimensions: 561 x 278 x 186 mm
Net weight: 14 kg



W-530D

Smoke machine 3000 W

Code : B04843



Heating element: 3000W
Preheating time: 12 minutes
Tank: 6 litres
Output volume: 1132 m3/min
Max. consumption: 6 min/litre at 100%
Wireless remote included
Control panel: LCD display
Management: Volume, Timer
DMX mode: 1 channel
Integrated DMX wireless receiver
Use liquid: FLG-5
Power supply: 230V - 50Hz
Power consumption: 3000W max.
Dimensions: 581 x 278 x 186 mm
Net weight: 14 kg



Z-3000 II

Smoke machine 3000W + remote

Code : B04809



Heating element: 3000W
Preheating time: 12 minutes
Tank: 6 litres
Output volume: 1132 m3/min
Max. consumption: 200 ml/min at 100%
Detachable control panel:
Management: Volume, Timer, Manual
DMX mode: 1 channel
Use liquid: FLG-5
Power supply: 230V - 50Hz
Power consumption: 3000W max.
Dimensions: 581 x 278 x 186 mm
Net weight: 14 kg



Z-1500 II

Smoke machine 1500W + remote

Code : B04808



Heating element: 1500W
Preheating time: 9.5 minutes
Tank: 6 litres
Output volume: 566 m3/min
Max. consumption: 110 ml/min at 100%
Detachable control panel:
Management: Volume, Timer, Manual
DMX mode: 1 channel
Use liquid: FLG-5
Power supply: 230V - 50Hz
Power consumption: 1500W max.
Dimensions: 688 x 285 x 257 mm
Net weight: 14 kg



Z-30PRO-433

Wireless control module for Z-1500II / Z-3000II

Code : B04827



Z-1200 II

Smoke machine 1200W + remote

Code : B04807



Heating element: 1200W
Preheating time: 9.5 minutes
Tank: 2.5 litres
Output volume: 510 m3/min
Max. consumption: 90 ml/min at 100%
Control panel:
Management: Volume, Timer, Manual
DMX mode: 1 channel
Use liquid: FLG-5
Power supply: 230V - 50Hz
Power consumption: 1200W max.
Dimensions: 458 x 243 x 251 mm
Net weight: 10.9 kg



Smotec1500

Smoke machine DMX 1500W
With HF remote and control panel

Code : H9577



Heating element: 1500W
Preheating time: 8 minutes
Tank: 10 litres
Output volume: 566 m3/min
Max. consumption: 8.6 litres / hour
RF Remote control: on/off
Control panel: output interval + volume controls
DMX channel: 1
Use liquid:
Power supply: 230V - 50Hz
Power consumption: 1600W max.
Dimensions: 668 x 319 x 170 mm
Net weight: 15 kg





Smotec 1000
Smoke machine DMX 1000W
With HF remote and Timer

Code : H9576



Heating element: 1000W
Preheating time: 12 minutes
Tank: 2.8 litres
Output volume: 283m³ / minute
Max. consumption: 2.5 litres / hour
RF Remote control: on/off
Control panel: output interval + volume controls
DMX channel: 1
Use liquid:
Power supply: 230V - 50Hz
Power consumption: 1100W max.
Dimensions: 468 x 250 x 148 mm
Net weight: 11.4 kg



FX-1200
Smoke machine - 1200W

Code : B04895



Heating element: 1200W
Preheating time: 5 minutes
Tank: 2.5 litre
Output volume: 510 m³/minute
Wired and wireless remote included
Use liquid: FOG LIQUID HI-TECH or FOG LIQUID STD
Wireless FC-5 remote optional
Power supply: 230V - 50Hz
Power consumption: 1200W max.
Dimensions: 475 x 253 x 200 mm
Net weight: 6.55 kg



FX-700
Smoke machine - 700 W

Code : B04818



Heating element: 700W
Preheating time: 5 minutes
Tank: 0.8 litres
Output volume: 70 m³/minute
Wired remote included
Use liquid: FOG LIQUID HI-TECH or FOG LIQUID STD
Wireless FC-5 remote optional
Power supply: 230V - 50Hz
Power consumption: 700W max.
Dimensions: 330 x 160 x 130 mm
Net weight: 3.65 kg



FX-400
Petite machine à brouillard avec LEDs
Ambre

Code : B04897



Power supply: 220 to 240 V AC, 50 Hz
Power consumption: 400 W
Fuse (size: 5 x 20 mm) : 250 V/5 A
Preheating time: 2 to 3 min
Tank capacity: 0.5 l
Liquid to be used: JB Systems Standard or Hi-Tech fog liquid
Liquid consumption: 4 ml/min
LED: 3 x 3 W (amber)
Dimensions: 237 x 118 x 163 mm
Weight: 1.8 kg



FC-5
Wireless remote for FX-700

Code : B04819



Wireless remote for F-80Z, FX-700 and FX-100
The receiver's magnetic housing can be attached to the smoke machine
Range: ± 30m



MAGICAN
Fog in a tank

Code : B04833



Very original.
Fog in a tank!
For use in small rooms
Always ready for use
Non-toxic, non-irritating, does not damage ozone layer

EFFECT MACHINES



M-7 RGBA
Vertical smoke machine with an intense output to simulate CO2 effects.

Code : B04845



Light source: 22 3W LEDs
5 red, 6 green, 6 blue, 5 amber
Heating element: 1550W
Preheating time: 5 minutes
Tank: 2.5 litres
Max. consumption: 25 ml/ 10s at 100%
Functions with liquid FLC-5
HF remote with 4 programmable buttons
- Control panel with emission interval, smoke volume and LED management
DMX mode: 9 channels
Can operate in both vertical and horizontal position
Power supply: 230V - 50Hz
Power consumption: 1600W max.
Dimensions: 340 x 195 x 380 mm
Net weight: 10.9 kg



COLOR JET
Powerful vertical jet smoke machine with 6 3 W RGB LEDs

Code : B04892



Light source: 6x3W RGB LEDs
Heating element: 900W
Preheating time: 4 minutes
Tank: 2.5 litres
HF remote with 4 programmable buttons
DMX mode: 4 channels
Functions with liquid FLC-5
Power supply: 230V - 50Hz
Power consumption: 950W max.
Dimensions: 340 x 250 x 130 mm
Net weight: 5.5 kg



BUBBLE-01
Bubble machine

Code : B04893



This machine functions with a special ready to use liquid.
Use liquid: **BUBBLE LIQUID 5L**
Power supply: 230V - 50Hz
Power consumption: 30W max.
Dimensions: 200 x 240 x 210 mm
Net weight: 1.57 kg



S-500
Professional snow machine, controlled by DMX and set up in a flight case.

Code : B04848



DMX-controlled air volume and liquid flow
Tank: 20 litres
Max. consumption: 400 ml/min at 100%
Effect output equipped with a 10m air hose.
Control panel: LCD display
Volume and Timer Mode
Integrated DMX wireless receiver:
DMX mode: 2 channels
Horizontal movement motor PM-1 (120°) optional
Power supply: 230V - 50Hz
Power consumption: 890W max.
Dimensions: 592 x 551 x 651 mm
Net weight: 37.2 kg

NEW



YETI Mk2
Machine à neige avec contrôle DMX

Code : B04896



Mains power input: 230 V AC, 50 Hz
Power consumption: 1200 W
DMX connectors: 3-pin XLR input + output

Number of DMX channels: 1
Fuse: T 8 A/250 V (slow-blow 6 x 30 mm)

Tank capacity: 5l
Recommended liquid: JB Systems snow liquid
Dimensions: 530 x 260 x 320 mm (without suspension bracket)

Weight: 8.70 kg



PM-1
Horizontal movement motor for ANTARI S-500 snow machine.

Code : B04849



Horizontal movement motor (120°)
Compatible with S-500



BT-HURRICANE
DMX high power fan

Code : B04850



Studio and stage fan controlled by DMX
Power: up to 3500m³/h or 58m³/min (2060 cfm)
Sound level:
30 dB minimum speed - 72 dB maximum speed
Air flow direction adjustable over 180°
Continuous adjustment of air flow
Control options:
DMX 1 channel (XLR 3&5 pins)
Wireless DMX (WTR-DMX DONGLE option)
Manual operation (LED display)
Power supply: 230V - 50Hz
Power consumption: 200W max.
Dimensions: 584 x 476 x 397mm
Net weight: 16.5 kg

NEW



CASE FOR BT-HURRICANE
Flight case for BT-Hurricane

Code : B03277



PERFUMES AND LIQUIDS

SMOKE LIQUID		
Code	Name	Brand
B04837	HZL-5W - Water based Hazer Fluid - 5L	ANTARI
B04839	FLM-05 - Fog Liquid for FT-20 - 0.50L	BRITEQ
B04852	SL-5H - Super Dry Snow Fluid	ANTARI
B04836	FLP-6 - Fog Liquid for FT-100 (fire training) - 6L	ANTARI
B04838	FLG-5 - Heavy Fog Liquid - 5L (green)	ANTARI
H9656	HD5L - 5L high density smoke liquid drum SM CONTEST	CONTEST
B04835	FOG LIQUID HI-TECH 1L - Fogger liquid Hi-Tech, 1L	JB SYSTEMS
B04812	FOG LIQUID HI-TECH 5L - Fogger liquid Hi-Tech, 5L	JB SYSTEMS
B04810	FOG LIQUID STD 1L - Fogger liquid standard, 1L	JB SYSTEMS
B04811	FOG LIQUID STD 5L - Fogger liquid standard, 5L	JB SYSTEMS
B04834	FLC-5 - Superfast dissipating Fog for Jet Operation	ANTARI
H10491	MD6L - 6L medium density smoke liquid drum CONTEST	CONTEST
B04832	HZL-5 - Oil based Haze liquid, 5L	ANTARI
B04813	SNOW LIQUID 5L - Liquid for Snow machine 5L	JB SYSTEMS
B04831	FOAM LIQUID CC 20L - Concentrated foam liquid 20L	JB SYSTEMS
B04830	FOAM LIQUID CC 5L - Concentrated foam liquid 5L	JB SYSTEMS
B01911	BUBBLE LIQUID 5L - 5L liquid for bubble machine	JB SYSTEMS
PERFUMES		
H4748	FLAG/MINT - Smoke liquid perfume - Mint	CONTEST
H4749	FLAG/JASMINE - Smoke liquid perfume - Jasmine	CONTEST
H4750	FLAG/FLOWER - Smoke liquid perfume - Orange blossom	CONTEST
H4751	FLAG/APPLE - Smoke liquid perfume - Apple	CONTEST
H4752	FLAG/COCONUT - Smoke liquid perfume - Coconut	CONTEST
H4753	FLAG/VANILLA - Smoke liquid perfume - Vanilla	CONTEST
H4754	FLAG/TROPICAL - Smoke liquid perfume - Tropical	CONTEST
H4755	FLAG/LEMON - Smoke liquid perfume - Lemon	CONTEST
H4756	FLAG/LAVENDER - Smoke liquid perfume - Lavender	CONTEST
H4757	FLAG/STRAWBERRY - Smoke liquid perfume - Strawberry	CONTEST
B04822	Fragrance - Apple - Smoke liquid perfume	JB SYSTEMS
B04820	Fragrance - Coco - Smoke liquid perfume	JB SYSTEMS
B04823	Fragrance - Musk - Smoke liquid perfume	JB SYSTEMS
B04821	Fragrance - Strawberry - Smoke liquid perfume	JB SYSTEMS
B04825	Fragrance - Tutti Frutti - Smoke liquid perfume	JB SYSTEMS

WARNING

ONLY USE THE RECOMMENDED SMOKE LIQUIDS FOR YOUR MACHINES.

These liquids are compliant with the latest health and environmental regulations.

These liquids have been specially tested for your machine and guarantee the best possible results.

These are the only liquids that guarantee long term operation, use of other liquids will damage your machine by clogging the heating element and wearing out the pump.

Repairs for clogged heating elements will only be covered after expert evaluation. The warranty will only be valid if the recommended liquid was used.



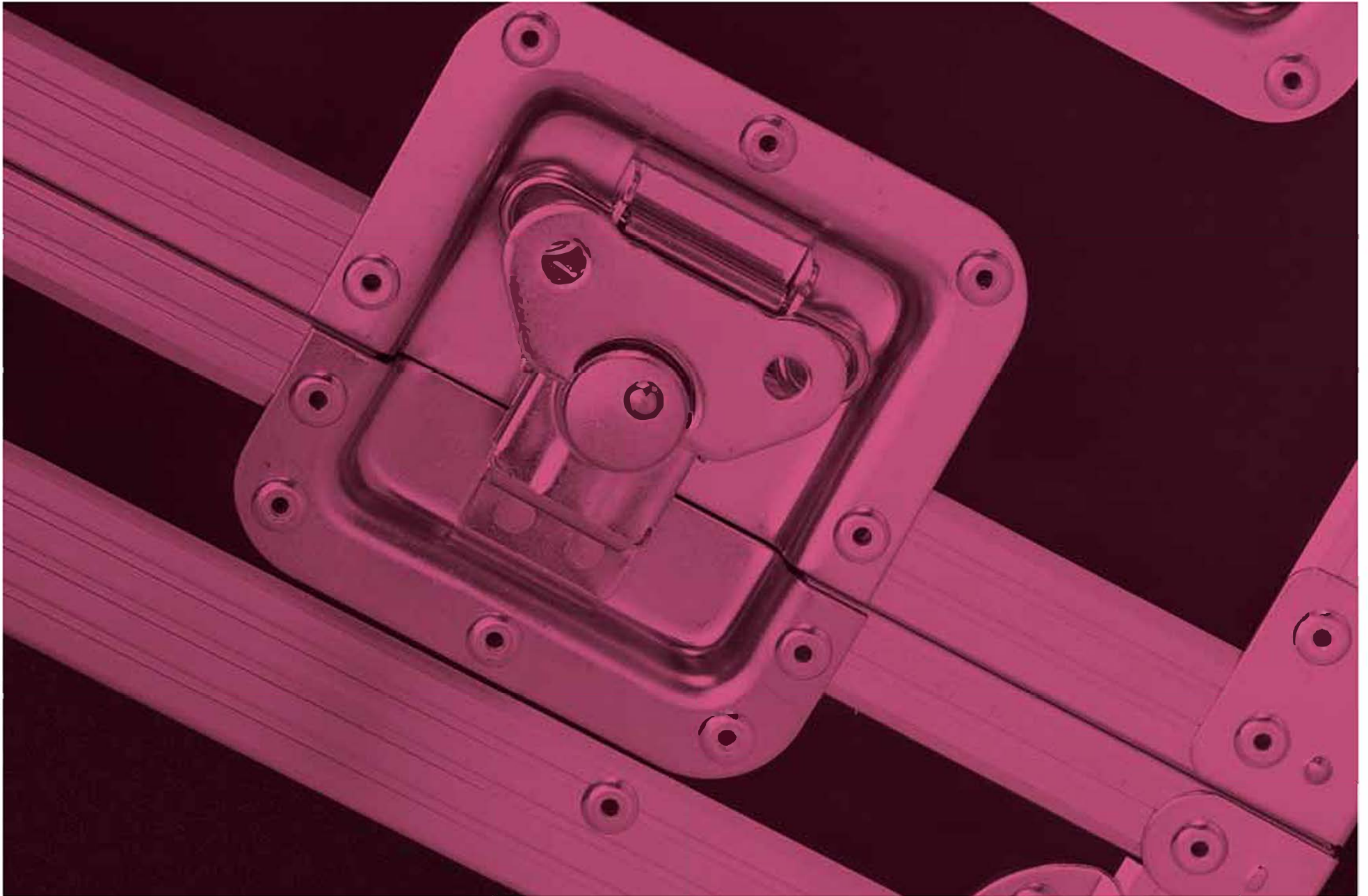

FLIGHT-CASES

AUDIO FLIGHT-CASES
FLIGHT-CASES FOR LIGHTS
19" RACKS

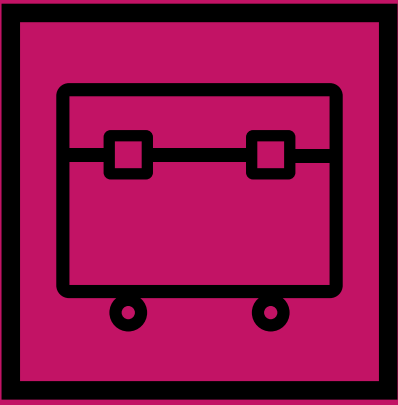

AUDIO FLIGHT-CASES



CASE FOR 2x SC-15
Flight-case for 2x SC-15.

Code : B03262



CASE FOR 2x SC-12
Flight-case for 2x SC-12.

Code : B03261



CASE FOR 4x SC-08
Flight-case for 4x SC-08

Code : B03260



CASE FOR 8x SC-05
Flight-case for 8x SC-05

Code : B03259



RACK CASE 10/18U
Convenient and versatile Flight-case.

Code : B03240



**CARPET DJ MIXER
CASE 5U+11U**
Carpeted DJ Flight-case.

Code : B03200



TT-CASE
High-quality modern flight-case for DJ
turntables (T2, T3, X-TRM1, SL1200, etc.).

Code : B03206



FLIGHT-CASES FOR LIGHTS

NEW



MOVING HEAD CASE 4
Flight case for 2x BTX-CIRRUS

Code : B03288



NEW



MOVING HEAD CASE 5
Flight case for 2x BTX-SATURN

Code : B03291



NEW



WHEELSET FOR WHEEL BOARD
Wheelset with 2 wheels with brake

Code : B03287



NEW



WHEEL BOARD 60x60CM
Wheel plate 60x60cm

Code : B03281



NEW



WHEEL BOARD 80x60CM
Wheel plate 60x80cm

Code : B03282



NEW



CASE FOR 4xACCU DECOLITE
Flight case for 4x Accu Decolite.

Code : B03279



NEW



CASE-3
Flight case for 6x BT-AKKULITE IP / ACCUCOLOR

Code : B03274



NEW



MULTIPURPOSE CASE 1
Flight case 60x80cm with dividers

Code : B03278



NEW



CASE FOR 2xBT-RETRO
Flightcase for 2 x BT-RETRO

Code : B03289



NEW



CASE FOR 3xBT-BLINDER2 IP
Flightcase for 3 x BT-BLINDER2 I

Code : B03290



NEW



PROJECTOR CASE 5
Flight case for 6 x BT-Theatre 50WW-60FC

Code : B03276



FLIGHT-CASES FOR LIGHTS



PROJECTOR CASE 4

Case for 4x BT-Theatre 250EZ & 100 EC Mk2.

Code : B03285

JVCase



PROJECTOR CASE 3

Case for BT-Coloray/Stage-Pro Beamer/Smar

Code : B03280

JVCase



CASE FOR 4x BT-NONABEAM

Flight case for 4 x BT-Nonabeam

Code : B03284

JVCase



CASE FOR 4x BT-LEDROTOR

Flight case for 4 x BT-Ledrotor

Code : B03283

JVCase



PREMIUM CASE FOR 4x BT-NONABEAM

Code : B03286

JVCase



FLY-Beam-Flex15Rx2

Flight-case for 2 Evora-Beam/Flex15R

Code : H10343

Contest



CASE FOR 2x BTX-TITAN

Flight-case for 2x BTX-TITAN

Code : B03251

JVCase



FLY2Fusion180

Flight-case for 2x FUSION180

Code : H10737

Contest



CASE FOR 2x BTX-BEAM 5R

Flight-case for 2x BTX-BEAM 5R.

Code : B03239

JVCase



FLY-RAY1R-HEZ0120x4

Flight-case for 4 RAY1R or 4 HEZ0120Z

Code : H10610

Contest



CASE FOR 4x BT-TRACKER

Flight-case for 4x BT-TRACKER.

Code : B03264

JVCase



CASE FOR 6x BEAM FURY-1

Flight-case for 6x BEAM FURY-1

Code : B03265

JVCase



FLY-DARTx6
Flight-case for 6x DART60 or DART60i ZOOM

Code : H10611



**CASE FOR
BEAM WIZARD5x5**
Flight-case for 2x BT-BEAM WIZARD

Code : B03256



FLY2FLAG25i
Flight-case for 2 x FLAG25i

Code : H10428



FLY2ROT0R7i
Flight-case for 2 x ROT0R7i

Code : H10429



**CASE FOR
2x BT-DAZZLE**
Flight-case for 2 x BT-DAZZLE.

Code : B03258



MOVING HEAD CASE 3
Flight-case for 4x BTX-SATURN

Code : B03273



FLY4Hezo300ZR
Flight-case for 4 x HEZO300ZR

Code : H10736



**CASE FOR 4x BT-
W36L3 / BT-W07L12**
For 4xBT-W36L3 / 4xBT-W07L12

Code : B03235



FLIGHT-CASES FOR LIGHTS



MOVING HEAD CASE2

Flight-case for 4x BT-Orbit/BT-W19L10 ZOOM

Code : B03272



CASE FOR 4x STRIKER

Flight-case for 4x STRIKER

Code : B03267



CASE FOR 4x TORNADO 7

Flight case for 4pcs TORNADO 7

Code : B03247



Fly4Ninja-S1

Flight-case for 4 x Ninja-7x15QC

Code : H10076



CASE FOR 2x BTX-HAWK

Flight-case for 2x Briteq BTX-HAWK

Code : B03263



FLY2CLUB-S1

Flight-case for Typhoon/Thunder/Cyclone/Wave

Code : H10247



MOVING HEAD CASE1

Flight-case for 2x BT-METEOR, BT-70LS, BT-BEAM70

Code : B03255



LIGHT EFFECT CASE 4

Flight-case for 2x LYNX, 2x BT-20LS, 2x BT-30FC or 2x BT-W12L10 ZOOM

Code : B03225



LIGHT EFFECT CASE 1

Flight-case for light effects.

Code : B03216



LIGHT EFFECT CASE 3

Flight-case for light effects (e.g. 2x LED CLUBSCAN OR 2x DYNAMO scan)

Code : B03223



LIGHT EFFECT CASE 7

Flight-case for The Winner II, Led Victoryscan, Led Spinner

Code : B03233



FLY4FRESNEL

For 4 Fresnel 150-250 projectors

Code : H10888





PROJECTOR CASE
Flight-case for 4x projectors with clamps

Code : B03253



PROJECTOR CASE 2

Flight-case for POWERPIXEL8-RGB
POWERPIXEL4-RGB, BEAMBAR10-RGBW,
BEAMBAR5-RGBW

Code : B03257



CASE FOR COB-4BAR

Lightweight and compact case, specially
designed to carry a COB-4BAR

Code : B03249



FLY4Sunbar103

Flight-case for 4x SUNBAR103W

Code : H10738



FLY-HELIWAVEx2

Flight-case for 2x HELIWAVE

Code : H10340



FLY-irLED64x6

Flight-case for 6x PAR64

Code : H10338



FLY8-irLEDFLAT

Flight-case for 8x FLAT12SIX

Code : H10739



FLIGHT-CASES FOR LIGHTS



**CASE for
4x COB-PLANO**
4x COB-PLANO + LEDCON-02 Mk2

Code : B03252



FLY-IPairx6
Flight-case for 6x IPair5x125ix

Code : H10464



FLY4IPANEL
Flight-case for 4 IPANEL24x100C

Code : H10866



**CASE for
2x BT-VINTAGE**
Flight-case for 2x BT-VINTAGE

Code : B03271



MATRIX5x5-CASE
Flight-case for 6x MATRIX5x5

Code : B04422



**CASE for
6x BT-GLOWPANEL**
Flight-case for 6x BT-GLOWPANEL

Code : B03269



FLY-HAZETEC
Flight-case for HAZETEC

Code : H10510



CABLE CASE
Extra solid Flight-case specially designed
to carry cables and other heavy objects.

Code : B03244

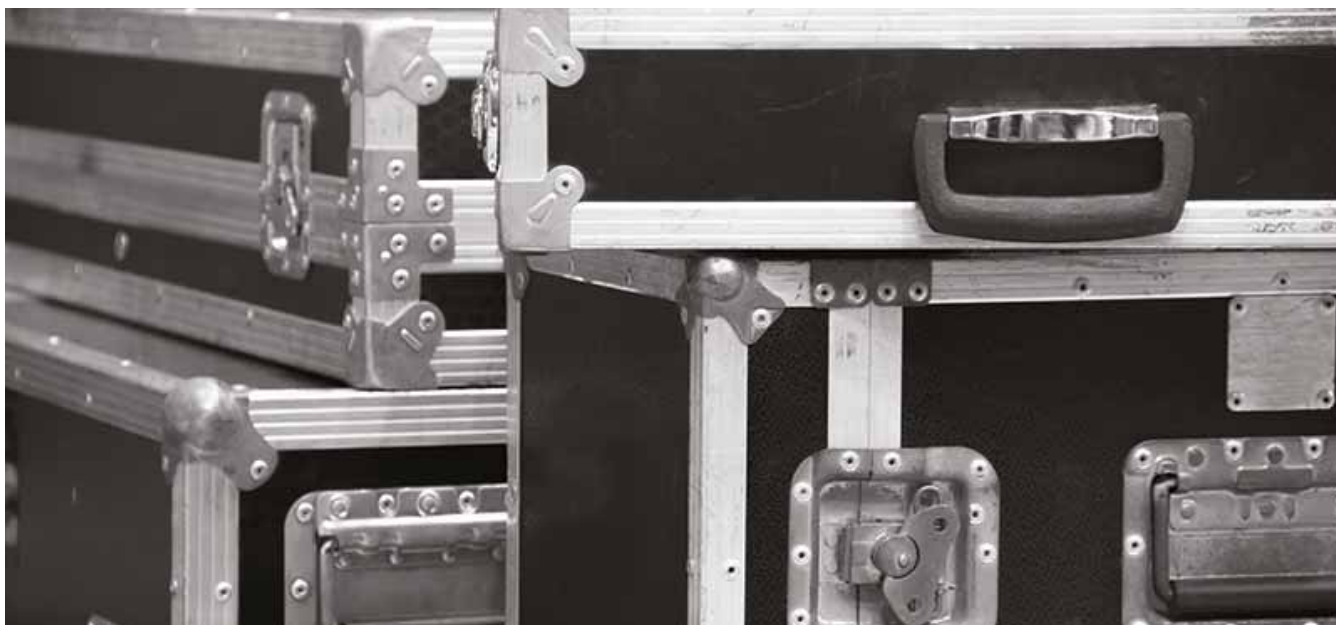

19" RACK



RACK CASE 16U
Standard 19" Flight-case 16U height,
castors included

Code : B03211



RACK CASE 12U
Standard 19" Flight-case 12U height,
castors included

Code : B03210



DJ CASE 10/6U
Standard 19" Flight-case 6U height +
10U top

Code : B03227



PRO 445-4U
Standard 19" Flight-case 4U height+
10U top

Code : B03222



RACK CASE 8U
Standard 19" Flight-case 8U height

Code : B03209



RACK CASE 6U
Standard 19" Flight-case 6U height

Code : B03219



RACK CASE 4U
Standard 19" Flight-case 4U height

Code : B03208



RACK CASE 2U
Standard 19" Flight-case 2U height

Code : B03212



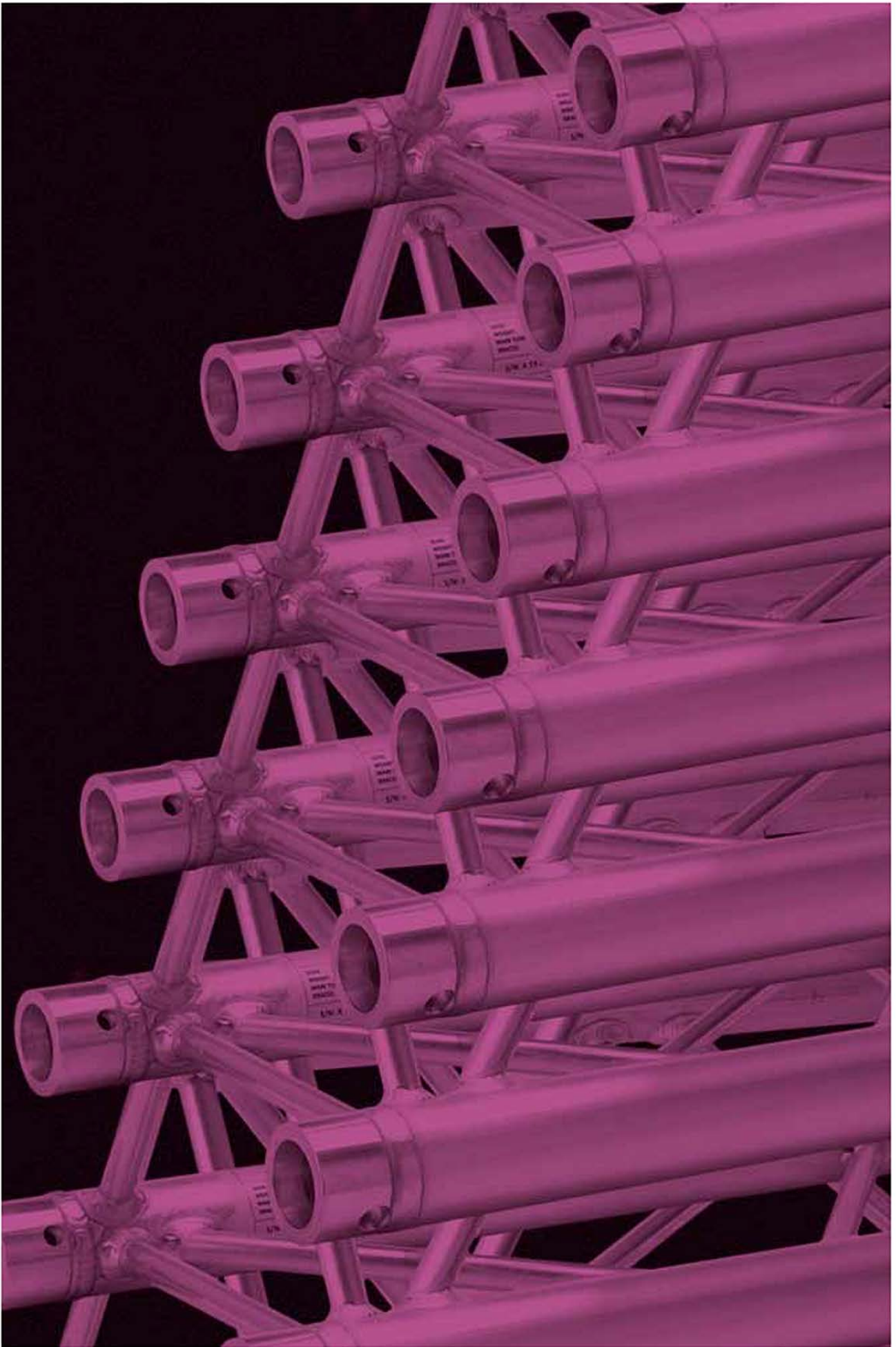

TRUSSS

QUATRO 290 TRUSS

QUATRO 220 TRUSS

TRIO 290 TRUSS

TRIO 220 TRUSS

TRIO 200 TRUSS

DUO 290 TRUSS

UNO TRUSS

DECO TRUSS

TOTEMS

RIGGING

WINCH STANDS

CABLE CHANNEL

PLATFORMS

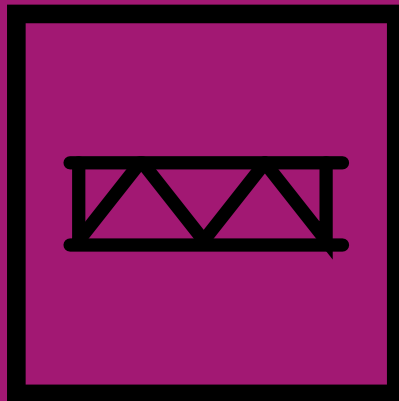

QUATRO 290 TRUSS



Manufacture according to DIN ISO 4113 and TÜV standards.
Aluminium alloy truss (EN AW 6082 T6) 50 mm in diameter and 2 mm thick

50 mm tubes
16 mm braces
Square section with 240 mm spacing between each tube (290 mm exterior)

Assembly with conical coupler, spigot pin and Safety R-springs
Section: 290 mm

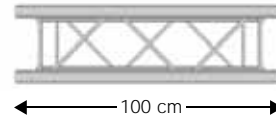
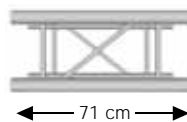
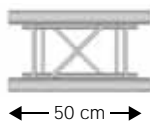
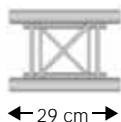

QUA29-029

Square aluminium truss - 290 mm
Length 29 cm

Code : H10118



QUA29-050

Square aluminium truss - 290 mm
Length 50 cm

Code : H10049



QUA29-071

Quatro aluminium truss - 290 mm
Length 71 cm

Code : H10593



QUA29-100

Square aluminium truss - 290 mm
Length 100 cm

Code : H10050



QUA29-200

Square aluminium truss - 290 mm
Length 200 cm

Code : H10051

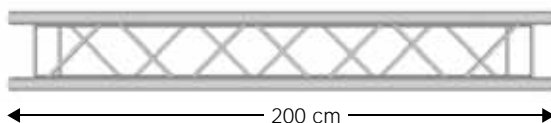

QUA29-300

Square aluminium truss - 290 mm
Length 300 cm

Code : H10052

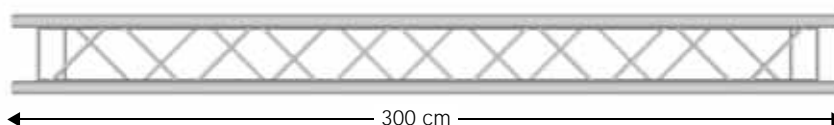

The CONTEST® truss comes with :
• 1 connection kit per bar

LENGTH (M)	↔	4	6	8	10	12	14	16
Max centred load (kg)	▼	1177	776.8	574.2	450.8	366.9	305.6	258.5
Deformation (mm)	⤵	12.3	27.9	49.8	78.4	113.8	156.4	206.6
Max distributed load (kg/m)	▼▼▼	449.5	258.9	143.6	90.2	61.2	43.7	32.3
Deformation (mm)	⤵	11.8	34.7	61.7	96.6	139.5	190.4	249.5

The load tables show the weight limits supported between two fixed hook points.
Centred or distributed loads cannot be added together. Consult a qualified technician.



Manufacture according to DIN ISO 4113 and TÜV standards.
Aluminium alloy truss (EN AW 6082 T6) 50 mm in diameter and 2 mm thick

50 mm tubes
16 mm braces
Square section with 240 mm spacing between each tube (290 mm exterior)

Assembly with conical coupler, spigot pin and Safety R-springs
Section: 290 mm

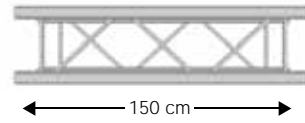
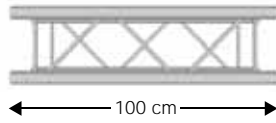
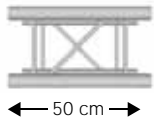

BT-TRUSS QUAT 29050

Square aluminium truss - 290 mm
Length 50 cm

Code : B03650



BT-TRUSS QUAT 29100

Square aluminium truss - 290 mm
Length 100 cm

Code : B03651



BT-TRUSS QUAT 29150

Square aluminium truss - 290 mm
Length 150 cm

Code : B03654



BT-TRUSS QUAT 29200

Square aluminium truss - 290 mm
Length 200 cm

Code : B03652

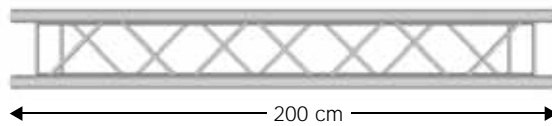

BT-TRUSS QUAT 29250

Square aluminium truss - 290 mm
Length 250 cm

Code : B03657

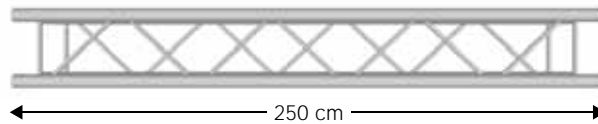

BT-TRUSS QUAT 29300

Square aluminium truss - 290 mm
Length 300 cm

Code : B03653

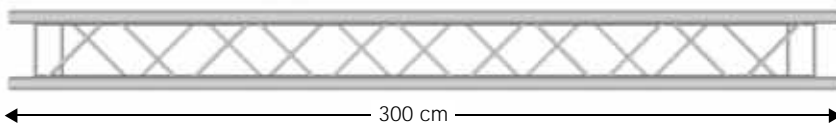

The BRITEQ® truss is delivered WITHOUT the connection kit

LENGTH (M)	↔	4	6	8	10	12	14	16
Max centred load (kg)	▼	1177	776.8	574.2	450.8	366.9	305.6	258.5
Deformation (mm)	⌒	12.3	27.9	49.8	78.4	113.8	156.4	206.6
Max distributed load (kg/m)	▼▼▼	449.5	258.9	143.6	90.2	61.2	43.7	32.3
Deformation (mm)	⌒	11.8	34.7	61.7	96.6	139.5	190.4	249.5

The load tables show the weight limits supported between two fixed hook points.
Centred or distributed loads cannot be added together. Consult a qualified technician.



QUATRO 290

STRUCTUREZ VOTRE ESPACE

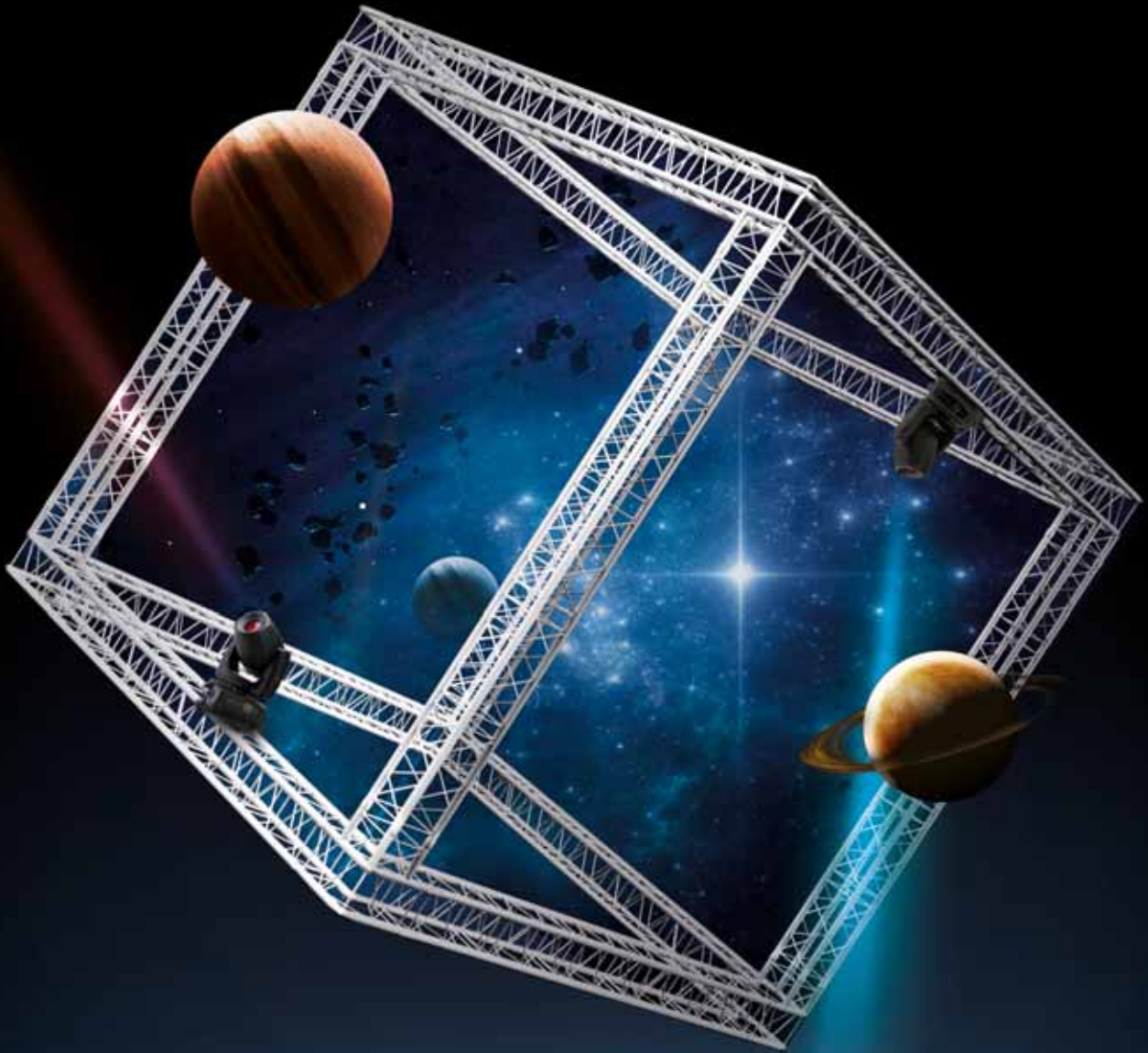

by  **Contestage**

QUATRO 290 TRUSS

- The CONTEST® truss comes with :
- 1 x connection kit, angle – 2 directions
 - 2 x connection kits, angle – 3, 4 and 5 directions



AGQUA-01
Quatro angle - 80 cm 60° - 2 directions

Code : H10053

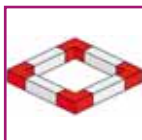

AGQUA-02
Quatro angle - 50 cm 90° - 2 directions

Code : H10054



AGQUA-03
Quatro angle - 50 cm 120° - 2 directions

Code : H10055



AGQUA-04
Quatro angle - 50 cm 135° - 2 directions

Code : H10056

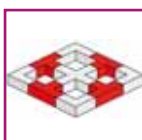
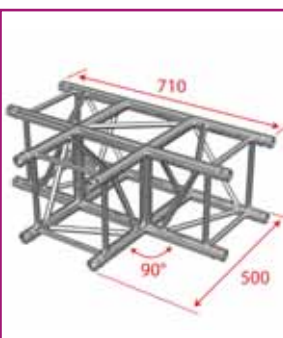

AGQUA-05
Quatro angle - 90° - 3 directions

Code : H10057



AGQUA-06
Quatro angle - 90° - 4 directions

Code : H10058

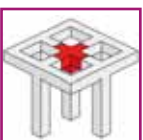

AGQUA-07
Quatro angle - 90° - 5 directions

Code : H10059

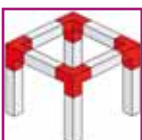

AGQUA-09
Quatro side piece - 3 directions

Code : H10061

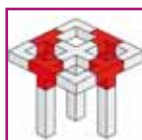

AGQUA-10
Quatro side piece - 4 directions

Code : H10062



The BRITEQ® truss is delivered WITHOUT the connection kit

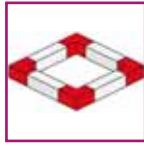

BT-TRUSS QUAT 29 - A003
Quatro angle - 90° - 2 directions

Code : B03660

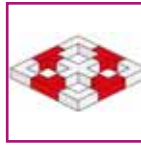

BT-TRUSS QUAT 29 - A017
Quatro angle - 90° - 3 directions

Code : B03666



BT-TRUSS QUAT 29 - A016
Quatro angle - 90° - 4 directions

Code : B03667

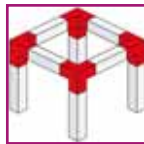

BT-TRUSS QUAT 29 - A012
Quatro side piece - 3 directions

Code : B03665

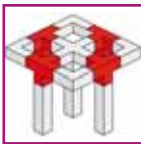

BT-TRUSS QUAT 29 - A020
Quatro side piece - 4 directions

Code : B03668

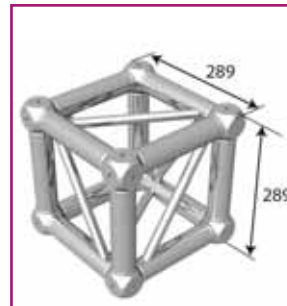

AGCUB290
Connection cube for 290 mm square truss

Code : H10433

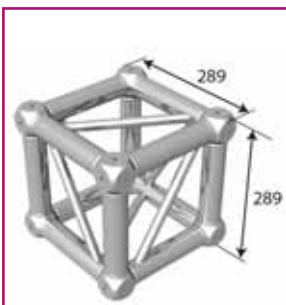

BT-TRUSS QUAT 29 - BOX CORNER
Connection cube for 290 mm square truss

Code : B03670



BT-TRUSS QUAT 29 - BOX Coupler Set (4 pcs)
4 sets of couplers for BT-TRUSS QUAT 29 - BOX CORNER.

Code : B03671



QUATRO 290 TRUSS



BT-TRUSS 29-TROLLEY-BASE

Trolley + wheels for 290 mm truss

Code : B03495



BT-TRUSS 29-TROLLEY-STACK

Stacking support for 290 mm

Code : B03496



BT-TRUSS 29-TROLLEY-TOP

Trolley beams for 290 mm

Code : B03497



EMQUA-B1

Quatro aluminium baseplate with couplers, keys and pins. 290x290 mm

Code : H10064



BT-TRUSS QUAT 29 - BASEPLATE

Quatro baseplate + half-couplers

Code : B03680



BT-TRUSS Q/T 29 BASE80

41 Kg heavy baseplate for Trio/Quat 290 with half-couplers, 800 x 800 mm

Code : B03684

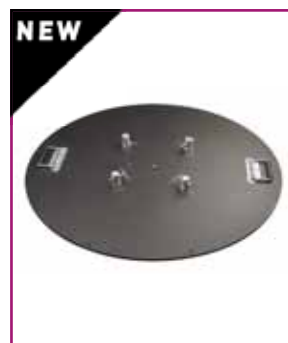

EM29BLOU40D90

40 kg heavy baseplate for TRIO/QUATRO 290 of 90 cm diam

Code : H10835



EM29BLOU29D74

40 kg heavy baseplate for TRIO/QUATRO 290 of 74 cm diam - 29kg

Code : H10463



MCQUA-KIT

Set of 4 conical couplers, 8 spigot pins and 8 Safety R-springs

Code : H10063



BT-TRUSS QUAT 29 - COUPLER SET

ALU TRUSS Quatro 290 coupler set (4pcs)

Code : B03681



BT-TRUSS QUAT/TRIO 29 - SPIGOT + THREAD

Quatro/Trio 290 Spigot with thread (1pc)

Code : B03682



TRIO 290 TRUSS



Manufacture according to DIN ISO 4113 and TÜV standards.
Aluminium alloy truss (EN AW 6082 T6) 50 mm in diameter and 2 mm thick.

50 mm tubes
16 mm braces
Triangular section with 240 mm spacing between each tube (290 mm exterior)

Assembly with conical coupler, spigot pin and Safety R-springs
Average weight per metre: 4.5 kg
Section: 290 mm

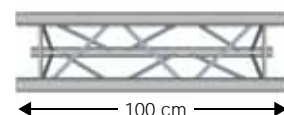
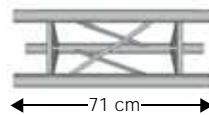
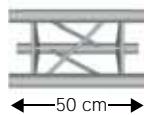
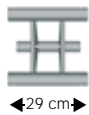

PT29-029

Aluminium truss - 290 mm
Length 29 cm

Code : H4213



PT29-050

Aluminium truss - 290 mm
Length 50 cm

Code : H3247



PT29-071

Trio aluminium truss - 290 mm
Length 71 cm

Code : H10592



PT29-100

Aluminium truss - 290 mm
Length 100 cm

Code : H3248



PT29-200

Aluminium truss - 290 mm
Length 200 cm

Code : H3249

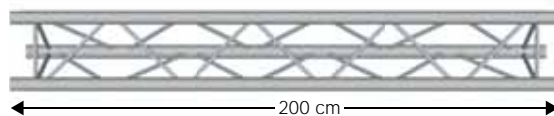

PT29-300

Aluminium truss - 290 mm
Length 300 cm

Code : H3250

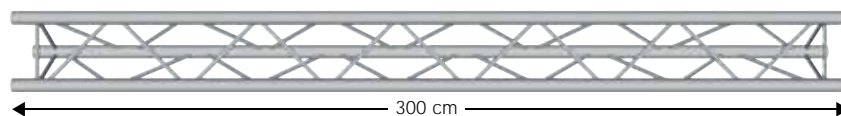

The CONTEST® truss comes with :
• 1 connection kit per bar

LENGTH (M)	↔	2	4	6	8	10	12
Max centred load (kg)	⏚	1023.9	506.4	331.5	242.2	187.2	149.2
Deformation (mm)	⏚	2.6	10.6	24	43.1	68.2	99.6
Max distributed load (kg/m)	⏚	783.1	253.2	110.5	60.6	37.4	24.9
Deformation (mm)	⏚	2.5	13.2	29.8	53	83.2	120.3

The load tables show the weight limits supported between two fixed hook points.
Centred or distributed loads cannot be added together. Consult a qualified technician.

50 mm tubes
16 mm braces
Triangular section with
240 mm spacing between each
tube (290 mm exterior)

Assembly with conical coupler,
spigot pin and Safety R-springs
Average weight per metre:
4.5 kg
Section: 290 mm



Manufacture according to DIN ISO 4113 and TÜV standards.
 Aluminium alloy truss (EN AW 6082 T6) 50 mm in diameter and 2 mm thick.

BT-TRUSS TRIO 29050

Aluminium truss - 290 mm
 Length 50 cm

Code : B03600

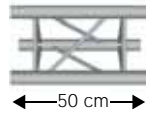

BT-TRUSS TRIO 29100

Aluminium truss - 290 mm
 Length 100 cm

Code : B03601

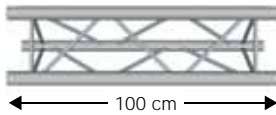

BT-TRUSS TRIO 29200

Aluminium truss - 290 mm
 Length 200 cm

Code : B03602

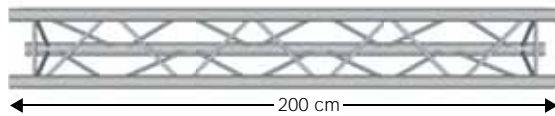

The BRITEQ® truss is delivered WITHOUT the connection kit

BT-TRUSS TRIO 29300

Aluminium truss - 290 mm
 Length 300 cm

Code : B03603

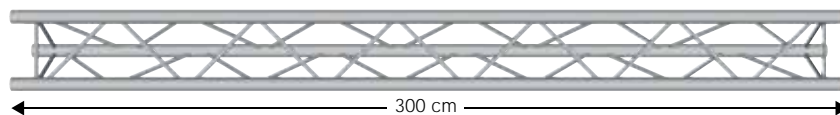

LENGTH (M)		2	4	6	8	10	12
Max centred load (kg)		1023.9	506.4	331.5	242.2	187.2	149.2
Deformation (mm)		2.6	10.6	24	43.1	68.2	99.6
Max distributed load (kg/m)		783.1	253.2	110.5	60.6	37.4	24.9
Deformation (mm)		2.5	13.2	29.8	53	83.2	120.3

The load tables show the weight limits supported between two fixed hook points.
 Centred or distributed loads cannot be added together. Consult a qualified technician.



TRIO 290 TRUSS

- The CONTEST® truss comes with :
- 1 x connection kit, angle – 2 directions
 - 2 x connection kits, angle – 3, 4 and 5 directions

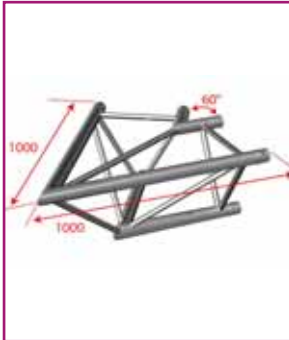

AG29-020

Angle - 290 mm 60° - 2 directions -

Code : H7015



AG29-021

Angle - 290 mm 90° - 2 directions -

Code : H3251

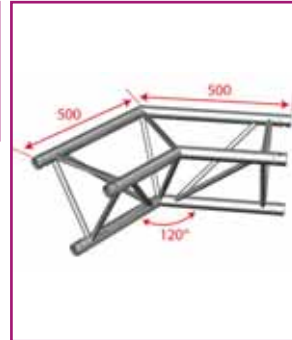

AG29-022

Angle - 290 mm 120° - 2 directions -

Code : H7016

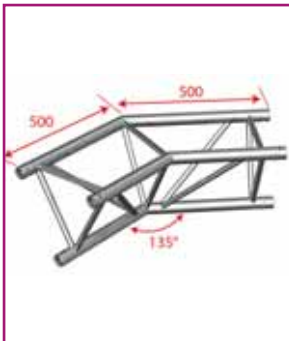

AG29-023

Angle - 290 mm 135° - 2 directions -

Code : H3252

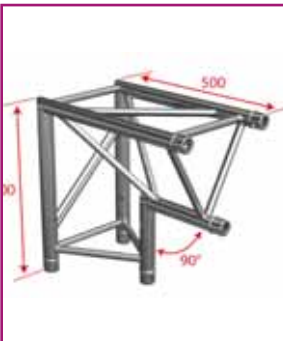

AG29-025

Angle - 290 mm 90° - 2 directions -
Inner vertex

Code : H3253



AG29-033

Angle - 290 mm 90° - 3 directions - Lower
upright vertex

Code : H3254



AG29-034

Angle - 290 mm 90° - 3 directions -
Lower left-hand vertex

Code : H3255

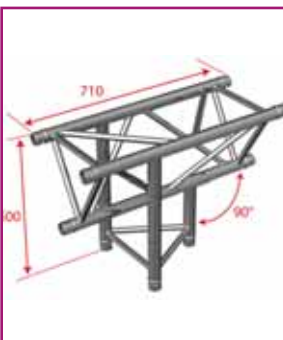

AG29-035

Vertical tee - 290 mm - 3 directions - Lower
vertex

Code : H3256

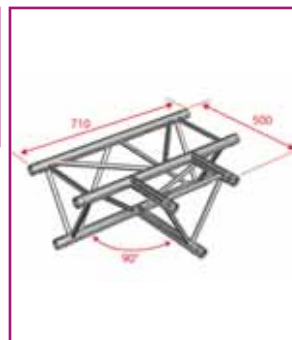

AG29-036

Horizontal tee - 290 mm 90° - 3 directions

Code : H3257



The BRITEQ® truss is delivered WITHOUT the connection kit

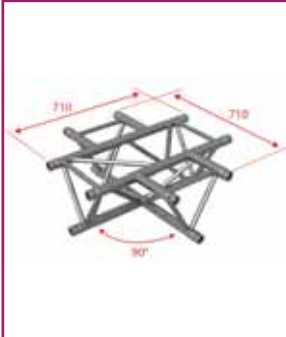

AG29-041

Cross - 290 mm - 4 directions

Code : H3258

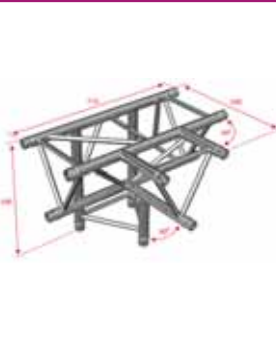

AG29-042

Tee - 290 mm - 4 directions - Apex down

Code : H3259

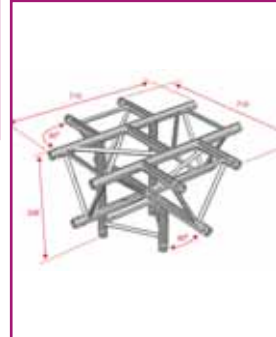

AG29-053

Cross - 290 mm - 4 directions plus base

Code : H4212



BT-TRUSS TRIO 29 - A003

Angle - 290 mm 90° - 2 directions -

Code : B03610



BT-TRUSS TRIO 29 - A007

Angle - 290 mm 90° - 2 directions - Apex down

Code : B03611

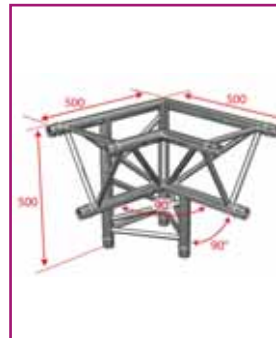

BT-TRUSS TRIO 29 - A013

Angle - 290 mm 90° - 3 directions - Apex down, right

Code : B03616



BT-TRUSS TRIO 29 - A012

Angle - 290 mm 90° - 3 directions - Apex down, left

Code : B03615



BT-TRUSS TRIO 29 - A018

Vertical tee - 290 mm - 3 directions - Apex down

Code : B03618

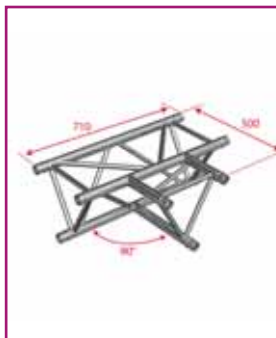

BT-TRUSS TRIO 29 - A017

Horizontal tee - 290 mm 90° - 3 directions

Code : B03617



TRIO 290 TRUSS

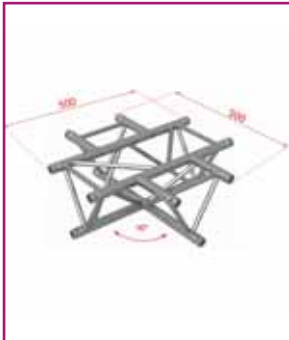

BT-TRUSS TRIO 29 - A016

Cross - 290 mm - 4 directions

Code : B03619



BT-TRUSS TRIO 29 - A020

Tee - 290 mm - 4 directions - Apex down

Code : B03620

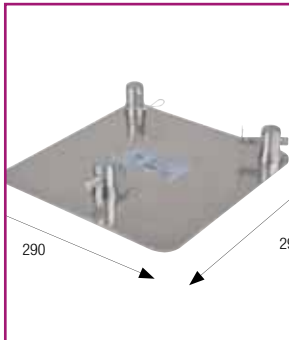

EM29-B3

Triangular truss baseplate - 290 mm with conical couplers, spigot pins and Safety R-springs

Code : H8884



EM29-B3T

Light triangular baseplate for PT29

Code : H10833



MC29-KIT

Set of 3 conical couplers, 6 spigot pins and 6 Safety R-springs

Code : H3261

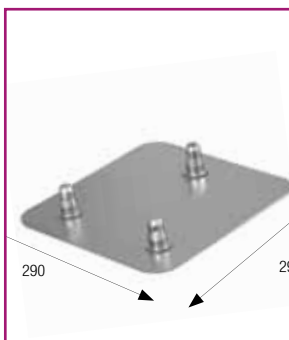

BT-TRUSS TRIO 29 - BASEPLATE

290 mm baseplate with half-couplers

Code : B03630



BT-TRUSS TRIO 29 - COUPLER SET

Set of 3 conical couplers, 6 spigot pins and 6 Safety R-springs

Code : B03631



EM29BLOU40D90

40 kg heavy baseplate for TRIO/QUATRO 290 of 74 cm diam - 29kg

Code : H10835



EM29BLOU29D74

40 kg heavy baseplate for TRIO/QUATRO 290 of 74 cm diam - 29kg

Code: H10463



TRIO 220 TRUSS



Manufacture according to DIN ISO 4113 and TÜV standards.
Aluminium alloy truss (EN AW 6082 T6)
50 mm in diameter and 2 mm thick.

35 mm tubes
8 mm braces
Triangular section with
185 mm spacing between each
tube (220 mm exterior)

Assembly with conical coupler,
spigot pin and Safety R-springs
Section: 220 mm

DEC022T-PT50

Triangular aluminium truss - 20 mm
Length 50 cm

Code : H10229

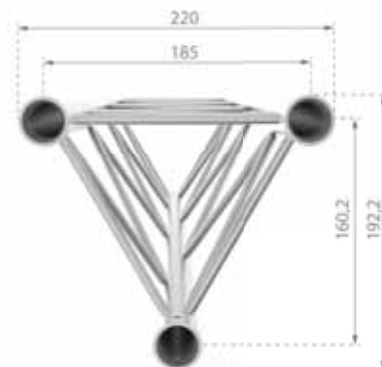
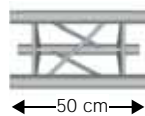

DEC022T-PT100

Triangular aluminium truss - 220 mm
Length 100 cm

Code : H10230

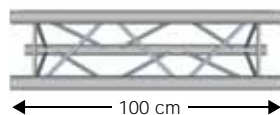

DEC022T-PT200

Triangular aluminium truss - 220 mm
Length 200 cm

Code : H10231

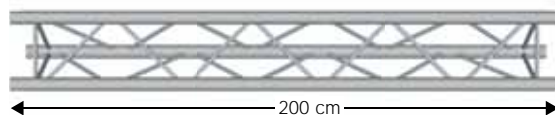

The CONTEST® truss comes with :

- **1 connection kit per bar**
- **1 x connection kit, angle - 2 directions**
- **2 x connection kits, angle - 3 and 4 directions**

LENGTH (M)		2	3	4	5	6
Max centred load (kg)		217.7	143.2	105.4	82.3	66.4
Deformation (mm)		1.9	4.2	7.5	11.9	17.3
Max distributed load (kg/m)		190.2	95.5	52.7	32.9	22.1
Deformation (mm)		2	5.2	9.3	14.6	21.1

The load tables show the weight limits supported between two fixed hook points.
Centred or distributed loads cannot be added together. Consult a qualified technician.



TRIO 220 TRUSS



**35 mm tubes
8 mm braces
Triangular section with
185 mm spacing between each
tube (220 mm exterior)**

**Assembly with conical coupler,
spigot pin and Safety R-springs
Section: 220 mm**

BT-TRUSS TRIO 22050

Triangular aluminium truss - 220 mm
Length 50 cm

Code : B03500

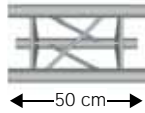

Manufacture according to DIN ISO 4113 and TÜV standards.
Aluminium alloy truss (EN AW 6082 T6) 50 mm in diameter and 2 mm thick.

BT-TRUSS TRIO 22100

Triangular aluminium truss - 220 mm
Length 100 cm

Code : B03501

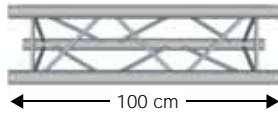

The BRITEQ® truss is delivered WITHOUT the connection kit

BT-TRUSS TRIO 22200

Triangular aluminium truss - 220 mm
Length 200 cm

Code : B03502

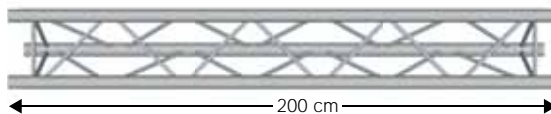

BT-TRUSS TRIO 22300

Triangular aluminium truss - 220 mm
Length 300 cm

Code : B03503

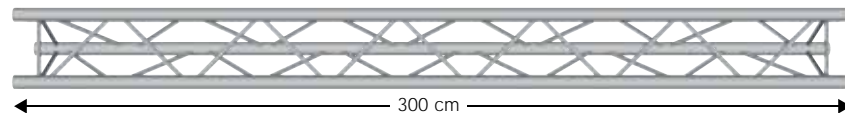

LENGTH (M)		2	3	4	5	6
Max centred load (kg)		217.7	143.2	105.4	82.3	66.4
Deformation (mm)		1.9	4.2	7.5	11.9	17.3
Max distributed load (kg/m)		190.2	95.5	52.7	32.9	22.1
Deformation (mm)		2	5.2	9.3	14.6	21.1

The load tables show the weight limits supported between two fixed hook points.
Centred or distributed loads cannot be added together. Consult a qualified technician.

TRIO 220 TRUSS

- The CONTEST® truss comes with :
- 1 x connection kit, angle – 2 directions
 - 2 x connection kits – 3, 4 directions



DEC022T-AG01

Triangular angle 220
2 directions - 50 cm 90°

Code : H10232



DEC022T-AG02

Triangular angle 220
3 directions - 50 cm 90° - upright

Code : H10233



DEC022T-AG03

Triangular angle 220
3 directions - 50 cm 90° - left-hand

Code : H10234



DEC022T-AG04

Triangular angle 220
3 directions - 90° - flat

Code : H10235

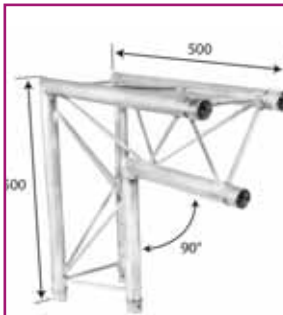

DEC022T-AG05

Triangular angle 220
2 directions - 50 cm 90° - right

Code : H10331

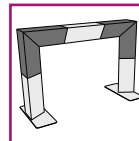

BT-TRUSS TRIO 22 - A003

Triangular angle 220
2 directions - 50 cm 90°

Code : B03510



BT-TRUSS TRIO 22 - A012

Triangular angle 220
3 directions - 50 cm 90° - upright

Code : B03515



BT-TRUSS TRIO 22 - A013

Triangular angle 220
3 directions - 50 cm 90° - left-hand

Code : B03516



BT-TRUSS TRIO 22 - A017

Triangular angle 220
3 directions - 90° - flat

Code : B03517



TRIO 220 TRUSS

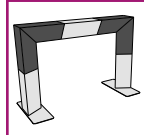

BT-TRUSS TRIO 22 - A007

Triangular angle 220
2 directions - 50 cm 90° - vertical

Code : B03511



BT-TRUSS TRIO 22 - A016

Triangular angle 220
4 directions

Code : B03519

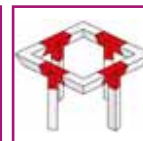

BT-TRUSS TRIO 22 - A018

Triangular angle 220
3 directions

Code : B03518



BT-TRUSS TRIO 22 - A020

Triangular angle 220
4 directions

Code : B03520



The BRITEQ® truss is delivered WITHOUT the connection kit

TRIO 220 TRUSS



DEC022T-EM-B1

Trio 220 baseplate with conical couplers, spigot pins and Safety R-springs

Code : H10237



BT-TRUSS TRIO/ QUAT 22 - BASEPLATE

Trio/Quatro 220 baseplate + half-couplers

Code : B03530



DEC022-EMB2

Rectangular baseplate for Deco arch for tube of 35. 620 x 240 mm

Code : H10333



DEC022-MANCH

Conical coupler for Deco series aluminium truss

Code : H10226



DEC022-1/2MANCH

1/2 conical coupler and M8 screw for tube of 35

Code : H10332



DEC022-CLAV

Spigot pin for conical coupler DEC022 series by unit

Code : H10227



DEC022-GOUP

Safety R-spring for spigot pin

Code : H10228



DEC022T-MC-KIT

Set of 3 conical couplers, 6 spigot pins and 6 Safety R-springs

Code : H10236



BT-TRUSS TRIO 22 - COUPLER SET

Set of 3 conical couplers, 6 spigot pins and 6 Safety R-springs

Code : B03531



DUO 290 TRUSS



Manufacture according to DIN ISO 4113 and TÜV standards.
Aluminium alloy truss (EN AW 6082 T6) 50 mm in diameter and 2 mm thick.

50 mm tubes
16 mm braces
Ladder with 240 mm spacing between each tube (290 mm exterior)

Assembly with conical coupler, spigot pin and Safety R-spring
Section: 290 mm

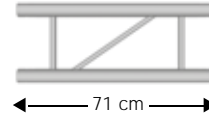
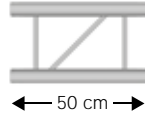
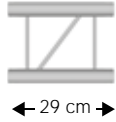

DU029-029

290 mm aluminium ladder - Length 29 cm

Code : H10036



DU029-050

290 mm aluminium ladder
Length 50 cm

Code : H10037



DU029-071

290 mm aluminium ladder
Length 71 cm

Code : H10607



DU029-100

290 mm aluminium ladder
Length 100 cm

Code : H10038

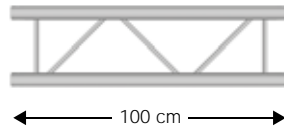

The CONTEST® truss comes with :
• 1 connection kit per bar

The DU0290 Contest series and the BT-TRUSS DU0 Briteq series are not compatible with each other (trusses and angles)

DU029-200

290 mm aluminium ladder
Length 200 cm

Code : H10039

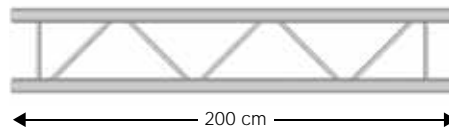

DU029-300

290 mm aluminium ladder
Length 300 cm

Code : H10040

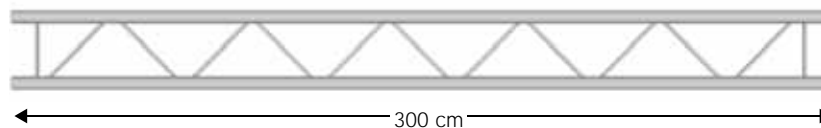

LENGTH (M)		2	3	4	5	6
Max centred load (kg)		904.3	787.9	589.1	469.4	389.2
Deformation (mm)		2.4	6.9	12.3	19.3	27.8
Max distributed load (kg/m)		452.2	300.7	225.0	179.6	129.7
Deformation (mm)		1.5	5.0	11.8	23.0	34.6

The load tables show the weight limits supported between two fixed hook points.

Centred or distributed loads cannot be added together. Consult a qualified technician.



Manufacture according to DIN ISO 4113 and TÜV standards.
Aluminium alloy truss (EN AW 6082 T6) 50 mm in diameter and 2 mm thick.

50 mm tubes
16 mm braces
Ladder with 240 mm spacing
between each tube (290 mm exterior)

Assembly with conical coupler, spigot pin and Safety R-spring
Section: 290 mm

BT-TRUSS DUO 29050
290 mm aluminium ladder
Length 50 cm

Code : B03449

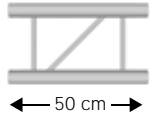

BT-TRUSS DUO 29100
290 mm aluminium ladder
Length 100 cm

Code : B03450

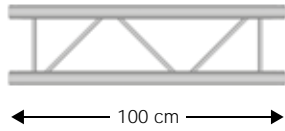

BT-TRUSS DUO 29200
290 mm aluminium ladder
Length 200 cm

Code : B03451

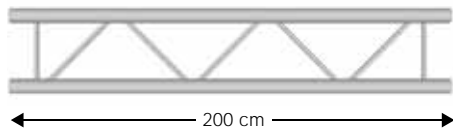

BT-TRUSS DUO 29300
290 mm aluminium ladder
Length 300 cm

Code : B03452

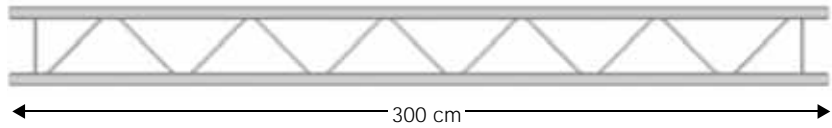

The BRITEQ® truss is delivered WITHOUT the connection kit
The DU0290 Contest series and the BT-TRUSS DUO Briteq series are not compatible (trusses and angles)

LENGTH (M)		2	3	4	5	6
Max centred load (kg)		904.3	787.9	589.1	469.4	389.2
Deformation (mm)		2.4	6.9	12.3	19.3	27.8
Max distributed load (kg/m)		452.2	300.7	225.0	179.6	129.7
Deformation (mm)		1.5	5.0	11.8	23.0	34.6

The load tables show the weight limits supported between two fixed hook points.
Centred or distributed loads cannot be added together. Consult a qualified technician.



DUO 290 TRUSS

The CONTEST® truss comes with :

- 1 x connection kit, angle - 2 directions
- 2 x connection kits, angle - 2, 3, 4 directions

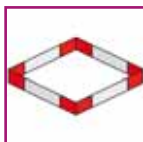

AGDU029-01

Corner joint - 2 directions - 90° - upright

Code : H10041

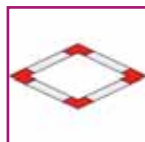

AGDU029-02

Corner joint - 2 directions - 90° - flat

Code : H10042



AGDU029-03

Corner joint - 3 directions - 90° - flat

Code : H10043

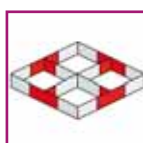

AGDU029-04

Corner joint - 3 directions - 90° - upright

Code : H10044

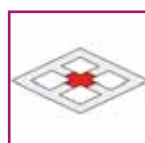

AGDU029-05

Corner joint - 4 directions - 90° - flat

Code : H10045

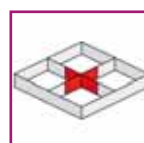
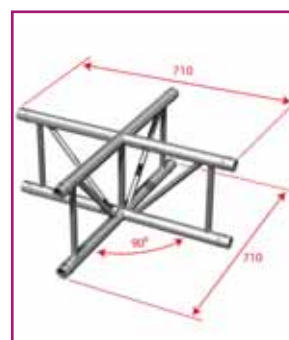

AGDU029-06

Corner joint - 4 directions - 90° - upright

Code : H10046



AGDU0-07

Corner joint - 3 directions - 45° - upright

Code : H10863



AGDU0-08

Corner joint - 3 directions - 90° - upright

Code : H10864



AGDU0-09

Corner joint - 3 directions - 45° - flat

Code : H10865



The BRITEQ® truss is delivered WITHOUT the connection kit

Attention: we provide the circles on demand. 60 days lead time.



BT-TRUSS DUO 29-A007

Aluminium ladder truss. Angle 90°.

Code : B03457



BT-TRUSS DUO 29-A003

Aluminium ladder truss. Angle 90°.

Code : B03456



EMDUO-B1

DUO baseplate 290 mm with conical couplers, spigot pins and Safety R-springs

Code : H10048



MCDUO-KIT

With 2 conical couplers, 4 spigot pins and 4 Safety R-springs

Code : H10047



SSL-Duo

Support for DU029 ladder on 35 mm base

Code : H10609



UNO TRUSS

The CONTEST® truss comes with :

- 1x coupler per tube
- 2x coupler per angle



UNO-50

Aluminium tube Diameter 50 mm
length 50 cm

Code : H10238



UNO-100

Aluminium tube Diameter 50 mm
length 100 cm

Code : H10239



UNO-150

Aluminium tube Diameter 50 mm
length 150 cm

Code : H10240



UNO-200

Aluminium tube Diameter 50 mm
length 200 cm

Code : H10241



UNO-50B

Aluminium tube Diameter 50 mm
length 50 cm-Black

Code : H10417



UNO-100B

Aluminium tube Diameter 50 mm
length 100 cm-Black

Code : H10418



UNO-150B

Aluminium tube Diameter 50 mm
length 150 cm-Black

Code : H10419



UNO-200B

Aluminium tube Diameter 50 mm
length 200 cm-Black

Code : H10420





BT-TRUSS Tube BLK 250
Extension for 'T' DROP ARM or 'H' FRAME.

Code : B03485



BT-TRUSS Tube BLK 500
Extension for 'T' DROP ARM or 'H' FRAME.

Code : B03486



BT-TRUSS Tube BLK 1000
Extension for 'T' DROP ARM or 'H' FRAME.

Code : B03487



BT-TRUSS Tube BLK 2000
Extension for 'T' DROP ARM or 'H' FRAME.

Code : B03488



UNO-AG01v2
Angle for tube Diameter 50 mm UNO + 2 x 1/2 coupler + spigot pin

Code : H10612



UNO-1/2MANCH
Additional half coupler for angle UNO-AG01

Code : H10254



UNO-T
Suspension T for hanging projectors 50 mm tube

Code : H10334



UNO-H
H-Frame for hanging projectors 50 mm tube

Code : H10335



UNO-A
Suspension bracket for projector for 50 mm tube. L 188 mm H 240 mm

Code : H10336

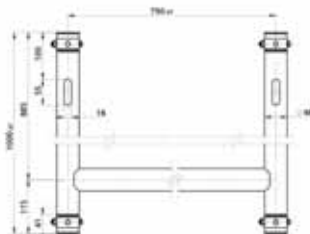
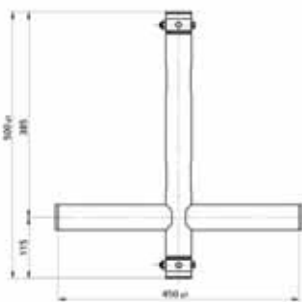

UNO TRUSS



**BT-TRUSS T-Drop arm
BLK 450x195**
Suspension T for hanging projectors

Code : B03483



**BT-TRUSS T-Drop arm
BLK 450x445**
Suspension T for hanging projectors

Code : B03482



**BT-TRUSS T-Drop arm Thru
BLK 450x500**
Suspension T for hanging projectors

Code : B03484



**BT-TRUSS H-Frame
BLK 750x1000**
H-Frame to hang projectors

Code : B03481



**BT-TRUSS H-Frame
BLK 750x415**
H-Frame to hang projectors

Code : B03480



BT-TRUSS Stirrup BLK
Projector suspension bracket for 50 mm tube.
L 188 mm H 240 mm

Code : B03489

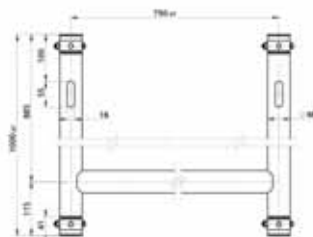
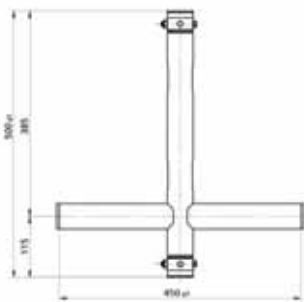

WINCH STANDS



Self-locking gear winch, combined with quality components and workmanship for high stability.

Transport and installation are facilitated by three articulated legs.

Ergonomic clamping wheel to eliminate play in the mast.



ELV-400PRO

Self-braking winch stand with 3 sections
4 metres - 80 kg

Code : H9996



Material: Treated steel
Electro-galvanized finish and black epoxy paint
Top mast: Ø 35 mm
Winch: Self-braking anti-return gear
Cable: Galvanized steel, diameter 5 mm
Max height: : 4,00 m
Max load: : 80 kg
Folded length: 1.59 m
Weight: 23 kg
TÜV approved



ALT 400

Pro stand w. winch 4,00m / 80kg

Code : B02601



Lifting stand with winch 4m load 80 kg
Anti-reverse winch equipped with a friction brake.
Masts with clearance adjustment system and lockable safety pin.
Legs with double crossbars and adjustable ground wheelbase.
New all-black finish.
Number of masts: 2
Max. load at 4m: 80 kg
Max. height: 4m
Minimum height: 1m75
Base: 1m15 / 1m85
Folded dimensions: 1m73
Section of the last mast: 35 mm square



ELV-270PRO

Self-braking winch stand with 2 sections
2.7 metres - 60 kg

Code : H9995



Material: Treated steel
Electro-galvanized finish and black epoxy paint
Top mast: Ø 35 mm
Winch: Self-braking anti-return gear
Cable: Galvanized steel, diameter 3 mm
Max height: : 2.70 m
Max load: : 60 kg
Folded length: 1.60 m
Weight: 12 kg
TÜV approved



LS-290

Self-braking winch stand - 3,00m / 60 kg

Code : B00747



Winch stand with automatic brake and lockable safety
Max height: : 3,00 m
Baseplate: 1,20 m
Section of the last mat: 35 mm
Maximum load: 60 kg
Folded length: 1,55 m
Weight: 12 kg
Made in France
TÜV, GS approved



LS-270

Economical self-braking 2,70m winch stand

Code : B00738



Winch stand with automatic brake and lockable safety
Max height: : 2,70 m
Section of the last mat: 35 mm
Weight: 11 kg
TÜV, GS approved



TOTEMS



TOTEM CONTEST® is delivered with:

- 4x Tubes
- 2x Baseplates
- 2x Connection kits
- 1x Spandex textile



TOT-100

Totem height 100 cm
With baseplates and fabrics

Code : H10243



TOT-150

Totem height 150 cm
With baseplates and fabrics

Code : H10244



TOT-200

Totem height 200 cm
With baseplates and fabrics

Code : H10245



TOTEM BRITEQ® is delivered with:

- 4x Tubes
- 2x Baseplates
- 2x Connection kits
- 1x Spandex textile



BT-TRUSS STAND 100

Totem height 100 cm
With baseplates and fabrics

Code : B03490



BT-TRUSS STAND 150

Totem height 150 cm
With baseplates and fabrics

Code : B03491



BT-TRUSS STAND 200

Totem height 200 cm
With baseplates and fabrics

Code : B03492





**BT-TRUSS STAND
100 TUBES**
Tubes for 100 cm TOTEM

Code : B03470



**BT-TRUSS STAND
150 TUBES**
Tubes for 150 cm TOTEM

Code : B03471



**BT-TRUSS STAND
150 TUBES**
Tubes for 200 cm TOTEM

Code : B03472



TOT-BASEground
Floor baseplate for Totem with 4 half-couplers

Code : H10255



TOT-BASEtop
Upper baseplate for Totem with 4 half-couplers

Code : H10256



TOT-CIRCLE
Circle in tube of 50 of 96 cm diam. for Totem

Code : H10834



**BT-TRUSS STAND
BASEPLATE ASSY**

Code : B03473



TOT-CIRCLE is the only circle held in stock



TOT-Spandex1
Elastic fire-resistant textile for 1m Totem

Code : H10257



TOT-Spandex1.5
Elastic fire-resistant textile for 1.5m Totem

Code : H10258



TOT-Spandex2
Elastic fire-resistant textile for 2m Totem

Code : H10259



TOT-Spandex1No
Elastic textile for 1m Totem - Black

Code : H10740



TOT-Spandex1.5No
Elastic textile for 1.5m Totem - Black

Code : H10741



TOT-Spandex2No
Elastic textile for 2m Totem - Black

Code : H10742



HOOK ACCESSORIES

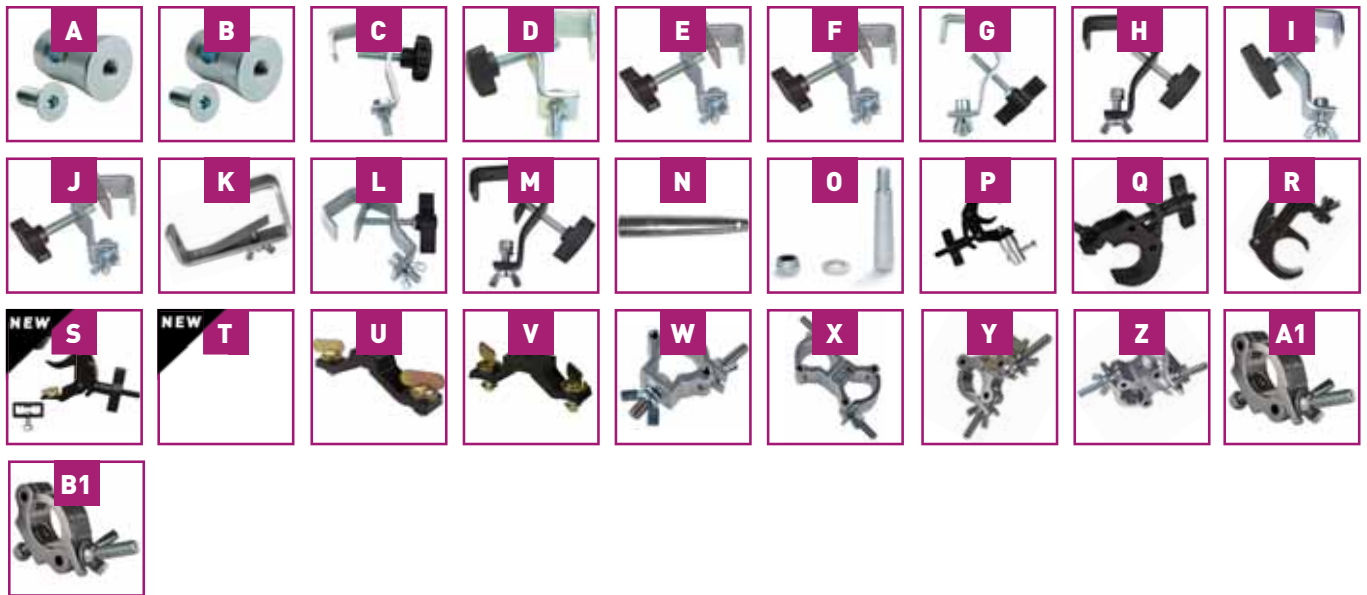

A	1/2MANCH Code : H6530	Conical half coupler Supplied with M12 x 12 screws, countersunk head		B	1/2MANCH-M10 Code : H10323	Conical half coupler with M10 screw for 50 mm tube	
C	CCT-20 Code : H7834	Professional clamp For 20 mm tube		D	CR20 Code : B02659	Professional clamp For 16-20 mm tube	
E	CR 30/LI Code : B02666	Clamp with protection plate.		F	CR30 Code : B02661	Professional clamp For 20-30 mm tube.	
G	CCT-50 Code : H3242	Professional clamp For 30 to 50 mm tube		H	CCT-50B Code : H10414	Professional clamp For 30 to 50 mm tube-Black	
I	CR50 Code : B02660	Professional clamp For 30-50 mm tube		J	CR50/LI Code : B02662	Clamp with protection plate.	
K	CCT-52 Code : H10330	Straight clamp with protection plate for 50 mm tube		L	CCT-55 Code : H7835	Clamp with protection plate For 30 to 50 mm tube	
M	CCT-55B Code : H10415	Clamp with protection plate for 30 to 50 mm tube-Black		N	CLAV Code : H6524	spigot pin for conical coupler / per piece	
O	CLAV/M8 Code : H7840	Key for conical coupler with M8 screw		P	BT-TRUSS Code : B03479	Clamp with 1/2 coupler: BLACK ALU - SWL:100 kg	
Q	FAST CLAMP V2 Code : B02684	Quick fastening clamp for trusses with tubes from 48 to 51 mm diameter.		R	ULTRA CLAMP Code : B06600	ULTRA CLAMP black Ultra fast clamp SWL 150kg tube 48-51mm	
S	FAST CLAMP GEN2 Code : B06601	FAST Clamp for use with base SWL 100kg		T	CLAMP BASE GEN2 Code : B06602	BASE for use with FAST CLAMP GEN2	
U	OMEGA BRACKET BIG Code : B02678	OMEGA clamp. Big version. Hole distance (centre to centre) : 141 mm.		V	OMEGA BRACKET SMALL Code : B02677	OMEGA clamp. Small version. Hole distance (centre to centre) : 106 mm.	
W	CLR-35 Code : H10324	Aluminium clamp for 35 mm tube - 50 kg load		X	CLR-70 Code : H10325	Double aluminium clamp for 35mm tube - 50 kg load	
Y	SWIVEL CLAMP 302-V2 Code : B02682	Double mounting clamp that can rotate 360°.		Z	SWIVEL CLAMP 502-V2 Code : B02683	Double mounting clamp that can rotate 360°	
A1	ALU CLAMP 101-V2 Code : B02687	Fixing clamp for trusses with 48-51 mm diameter tubes.		B1	ALU CLAMP 301-V2 Code : B02680	Fixing clamp for heavy duty applications for tubes from 48 to 51 mm diameter.	



C1	ALU CLAMP 501-V2 Code : B02681	Fixing clamp for heavy duty applications for tubes up to 48 mm diameter 51 mm		D1	ELG301 Code : H9967	1 mm steel wire. L30 cm 1 quick-release clip	
E1	ELG602 Code : H9969	2 mm steel wire. Length 60 cm, 1 quick-release clip		F1	SAFETY CABLE Code : B02685	Safety cable, diameter 2 mm, Length 60 cm.	
G1	SAFETY CABLE D4-60CM Code : B02686	4 mm steel wire. Length 60 cm.		H1	EL 90 Code : B02675	ASD Safety cable	
I1	EYE-10F Code : H10436	Female M10 eye bolt MWL 230 kg		J1	GOUP Code : H6525	Security R-spring by unit	
K1	PAT-50 Code : H7838	Fixing plate For 50 mm tube		L1	MANCH Code : H6523	Conical coupler by unit	
M1	SPT290 Code : H10027	Suspension piece for 290 mm truss		N1	T 350 Code : B02615	ASD Support pour les structures en aluminium	
O1	SST-35 Code : H3240	150 to 350 mm truss support for 35 mm base		P1	SST-20 Code : H8262	Fixing tee for PT20-150 truss on 28 mm base	
Q1	SST-22 Code : H10873	Fixing T for 220 Truss on 35mm base		R1	SUP-PIL Code : H10608	Post support with clamping chain	



PLATFORMS



FIRE RESISTANCE

Fire resistance class: **Bfl-S1** (corresponds to the French class **M1**). It conforms to the **EN13501-1+A1:2010** European standard.

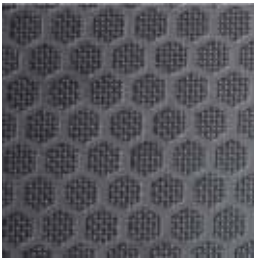

12mm black multi-ply anti-slip plywood

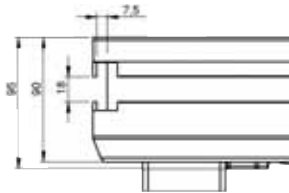

Internal structure of the multi-ply plywood platform and aluminium frame (EN AW6082T6)



NEW PLATFORMS NEW UNIVERSAL ANGLES

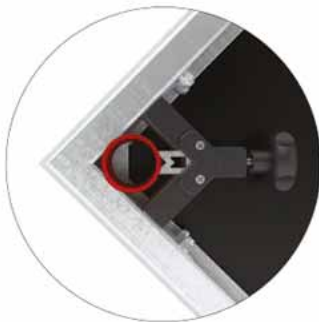

ROUND LEGS
48.3mm

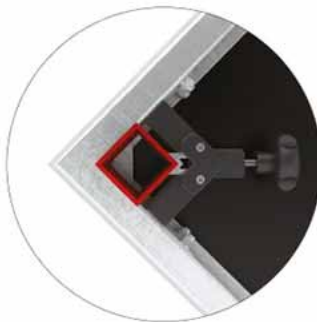

SQUARE LEGS
50X50mm

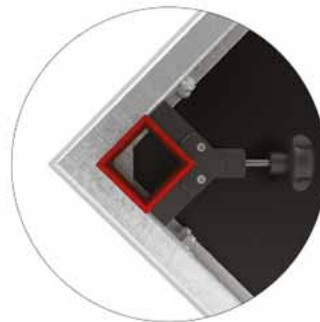

SQUARE LEGS
60X60 mm

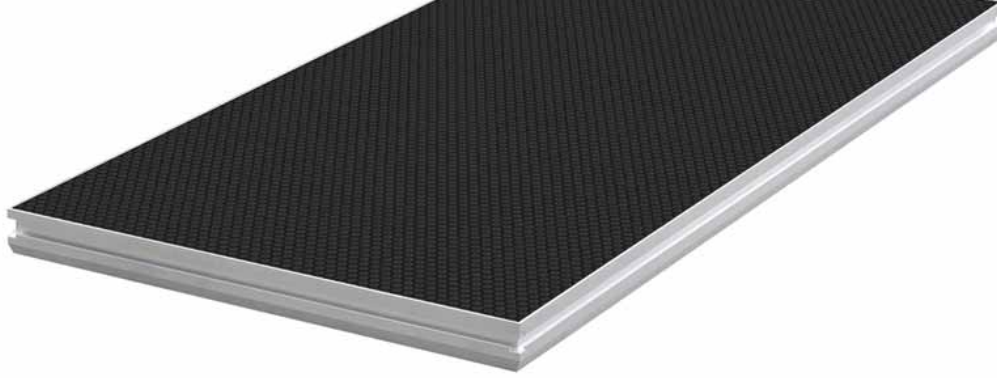

PLTS-1x1

1m Platform x 1m non-slip 750 kg/m²- black - Delivered without legs

Code : H10370



Material:
 - Frame: Aluminium
 - Tray: 12mm multi-ply
 Thickness: 90 mm
 Allowable distributed load: 750 Kg/m²
 Weight: 16 Kg



PLTS-2x1

2m Platform x 1m non-slip 750 kg/m²- black - Delivered without legs

Code : H10369



Material:
 - Frame: Aluminium
 - Tray: 12mm multi-ply
 Thickness: 90 mm
 Allowable distributed load: 750 Kg/m²
 Weight: 32 Kg



PLTS-1x0.5

Platform 1x0.5m non-slip 750 kg/m²- black - Delivered without legs

Code : H10602



Material:
 - Frame: Aluminium
 - Tray: 12mm multi-ply
 Thickness: 90 mm
 Allowable distributed load: 750 Kg/m²
 Weight: 8 Kg



PLTS-2x0.5

Platform 2x0.5m non-slip 750 kg/m²- black - Delivered without legs

Code : H10601



Material:
 - Frame: Aluminium
 - Tray: 12mm multi-ply
 Dimension : 2 m x 0.5 m
 Thickness: 90 mm
 Allowable distributed load: 750 Kg/m²
 Weight: 16 Kg



PLTS-T1x1

1x1m anti-slip triangular platform 750 kg/m²- black - Delivered without legs

Code : H10603



Material:
 - Frame: Aluminium
 - Tray: 12mm multi-ply
 Dimension : 1 x 1 m
 Thickness: 90 mm
 Allowable distributed load: 750 Kg/m²
 Weight: 8 Kg



PLTS-c1

Platform assembly clamp

Code : H10371



Material: Steel
 Thickness: 4 mm
 Weight: 0.42 Kg



PLT-j1

Junction insert

Code : H10372



Compatible with PLTL and PLTS series
 Material: Steel
 Thickness: 3 mm
 Weight: 78 g



PLT-j2

Leveling insert

Code : H10373



Compatible with PLTL and PLTS series
 Material: ABS
 Weight: 11 g



PLATFORMS



PLTS-ft4060

Telescopic square leg - 0.4 m to 0.6m - per unit

Code : H10374



Material: Aluminium
Thickness: 2 mm
Section: 60 x 60 mm
Weight: 1.66 Kg



PLTS-ft60100

Telescopic square leg - 0.6m to 1m - per unit

Code : H10375



Material: Aluminium
Thickness: 2 mm
Section: 60 x 60 mm
Weight: 1.8 Kg



PLTS-ft80140

Telescopic square leg - 0.8m to 1.4m - per unit

Code : H10403



Material: Aluminium
Thickness: 2 mm
Section: 60 x 60 mm
Weight: 2.5 Kg



PLTS-f20

Square leg 20 cm high - per unit

Code : H10376



Material: Aluminium
Thickness: 2 mm
Section: 60 x 60 mm
Weight: 0.42 Kg



PLTS-f40

Square leg 40 cm high - per unit

Code : H10377



Material: Aluminium
Thickness: 2 mm
Section: 60 x 60 mm
Weight: 0.78 Kg



PLTS-f60

Square leg 60 cm high - per unit

Code : H10378



Material: Aluminium
Thickness: 2 mm
Section: 60 x 60 mm
Weight: 1.15 Kg



PLTS-f80

Square leg 80 cm high - per unit

Code : H10379



Material: Aluminium
Thickness: 2 mm
Section: 60 x 60 mm
Weight: 1.52 Kg



PLTS-f100

Square leg 1 m high - per unit

Code : H10380



Material: Aluminium
Thickness: 2 mm
Section: 60 x 60 mm
Weight: 1.89 Kg

NEW



PLTS-FW24
Square leg with caster - Height 24,5 cm

Code : H10858



Material: Aluminium
Thickness: 3 mm
Section: 60 x 60 mm
Wheel diameter: 100 mm
Weight: 1.41 Kg

NEW



PLTS-FW40
Square leg with caster - Height 40 cm

Code : H10859



Material: Aluminium
Thickness: 3 mm
Section: 60 x 60 mm
Wheel diameter: 100 mm
Weight: 1.69 Kg

NEW



PLTS-FW60
Square leg with caster - Height 60 cm

Code : H10860



Material: Aluminium
Thickness: 3 mm
Section: 60 x 60 mm
Wheel diameter: 100 mm
Weight: 2.06 Kg

NEW



PLTS-FW80
Square leg with caster - Height 80 cm

Code : H10861



Material: Aluminium
Thickness: 3 mm
Section: 60 x 60 mm
Wheel diameter: 100 mm
Weight: 2.43 Kg

NEW



PLTS-FW100
Square leg with caster - Height 100 cm

Code : H10862



Material: Aluminium
Thickness: 3 mm
Section: 60 x 60 mm
Wheel diameter: 100 mm
Weight: 2.80 Kg



PLTS-fc2
Connecting clamp for two square legs

Code : H10381



Material: Aluminium
Thickness: 5 mm
For section: 60 x 60 mm
Weight: 0.48 Kg



PLTS-fc4
Connecting clamp for four square legs

Code : H10382



Material: Aluminium/Steel
Thickness: 4,5 mm
For section: 60 x 60 mm
Weight: 0.48 Kg



PLATFORMS



PLTS-g1x1

Bar railing lg 1 m without fastener

Code : H10421



Material: Aluminium
Diameter: 45.2 mm
Weight: 7.9 Kg
Length: 1 m
Height: 1.2 m



PLTS-g2x1

Bar railing lg 2 m without fastener

Code : H10422



Material: Aluminium
Diameter: 45.2 mm
Weight: 12 Kg
Length: 2 m
Height: 1.2 m



PLTS-gc1

Straight fastener for bar railing

Code : H10454



Straight fastener for guardrail:
PLTS-g2x1
PLTS-g1x1



PLTS-gc2

Angled fastener for bar railing

Code : H10455



Angled fastener for guardrail:
PLTS-g2x1
PLTS-g1x1

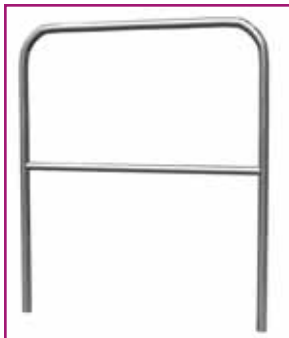

PLTS-h1x1

Guardrail for platform of 1m length
Supplied with fasteners

Code : H10392



Material: Aluminium
Thickness: 2 mm
Diameter: 35 mm
Weight: 2.83 Kg
Length: 1 m
Height: 1.2 m



PLTS-h2x1

Guardrail for platform of 2m length
Supplied with fasteners

Code : H10391



Guardrail fastener:
PLTS-h1x1
PLTS-h2x1
Material: Steel
Thickness: 4 mm
Weight: 0.45 Kg



PLTS-hc1

Platform guardrail fastener - per unit

Code : H10393



PLTS-hc2

STAGE series guardrail junction clamp

Code : H10394



Junction clamp for guardrail
PLTS-h1x1
PLTS-h2x1
Material: Steel
Thickness: 5.5 mm
Weight: 1.14 Kg

EXAMPLES OF CONFIGURATIONS WITH 4 PLTS PLATFORMS-2x1

NOTE: From a height of 1 metre and to maintain full stability of the assembly, it is advisable to install the connecting clamps for 2 legs (PLTS-fc2) and 4 legs (PLTS-fc4).

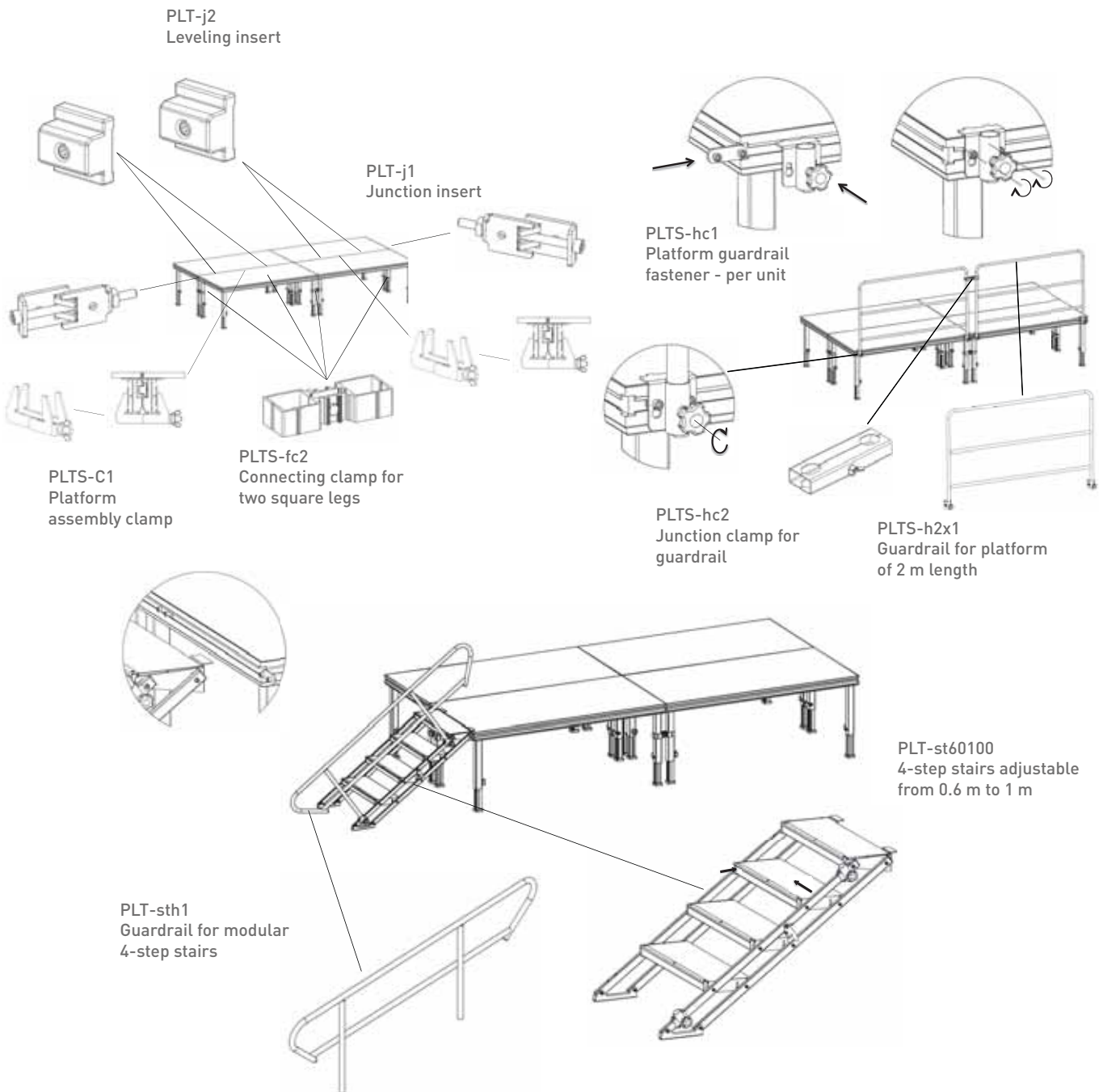

ATTENTION ON THE SOIL CAPACITY

Soft ground can affect the safety of the installation.
Please spread the loads evenly across the platform surface.

ABOUT THE GUARDRAIL & STAIRS

A guardrail must be installed when the height is greater than 50 cm.
Stairs less than or equal to 120 cm wide must have at least one handrail.

CAUTION IN ACCORDANCE WITH THE NF E85-015 STANDARD

A maximum height of 150 cm is allowed. A guardrail must be installed if the height to be climbed is greater than 50 cm.
These provisions are not exhaustive. For other prescriptions, obtain the standard quoted above.



PLATFORMS



BT-STAGE RS-PLF-2X1M

2x1m platform 750kg/m non-slip²- black - delivered without legs

Code : B03704



Material:
 - Frame: Aluminium
 - Tray: 12mm multi-ply
 Thickness: 90 mm
 Allowable distributed load: 750 Kg/m²
 Weight: 32 Kg



BT-STAGE RS PLF-2X0.5M

Platform 2x0.5m non-slip 750 kg/m²- black - Delivered without legs

Code : B03705



Material:
 - Frame: Aluminium
 - Tray: 12mm multi-ply
 Thickness: 90 mm
 Allowable distributed load: 750 Kg/m²
 Weight: 16 Kg



BT-STAGE RS PLF-1X0.5M

1x0,5 m platform 750kg/m non-slip²- black - delivered without legs

Code : B03707



Material:
 Frame: Aluminium
 Tray: 12mm multi-ply
 Thickness: 90 mm
 Allowable distributed load: 750 Kg/m²
 Weight: 11.8 Kg



BT-STAGE RS PLF-1X1M

2x1m platform 750kg/m non-slip²- black - delivered without legs

Code : B03706



Material:
 - Frame: Aluminium
 - Tray: 12mm multi-ply
 Thickness: 90 mm
 Allowable distributed load: 750 Kg/m²
 Weight: 18.3 Kg



BT-STAGE-PLFCLAMP-BIG

Platform assembly clamp

Code : B03721



Material: Steel
 Thickness: 4 mm
 Weight: 0.42 Kg



BT-STAGE-PLFCLAMP-SMALL (2pcs)

Code : B03720



Material: Steel
 Thickness: 3 mm
 Weight: 78 g each



BT-STAGE-PLFLEVEL (6pcs)

Code : B03724



Leveling insert
 Material: ABS
 Weight: 11 g each



BT-STAGE-LEGADJ-45/60CM

Telescopic round leg – 0.45m to 0.60m

Code : B03712



Material: Aluminium
Thickness: 3 mm
diameter: 48 mm
Weight: 1.78 Kg



BT-STAGE-LEGADJ-60/90 CM

Telescopic round leg – 0.60m to 0.90m

Code : B03713



Material: Aluminium
Thickness: 3 mm
diameter: 48 mm
Weight: 2.37 Kg



BT-STAGE-LEGFIX-20CM

Round leg, fixed height = 20cm, +/- 5cm adj.

Code : B03716



Material: Aluminium
Adjustable leg: up to 5 cm
Thickness: 3 mm
diameter: 48 mm
Weight: 0.30 Kg



BT-STAGE-LEGFIX-40CM

Round leg, fixed height = 40cm, +/- 5cm adj.

Code : B03710



Material: Aluminium
Adjustable leg: up to 5 cm
Thickness: 3 mm
diameter: 48 mm
Weight: 0.49 Kg



BT-STAGE-LEGFIX-60CM

Round leg, fixed height = 60cm, +/- 5cm adj.

Code : B03711



Material: Aluminium
Adjustable leg: up to 5 cm
Thickness: 3 mm
diameter: 48 mm
Weight: 0.72 Kg



BT-STAGE-LEGFIX-80CM

Round leg, fixed height = 80cm, +/- 5cm adj.

Code : B03714



Material: Aluminium
Adjustable leg: up to 5 cm
Thickness: 3 mm
diameter: 48 mm
Weight: 0.82 Kg

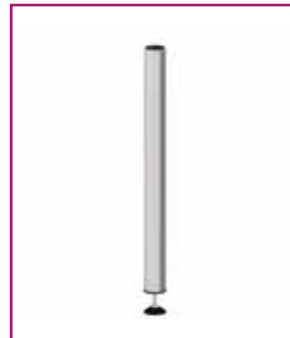

BT-STAGE-LEGFIX-100CM

Round leg, fixed height = 100cm, +/- 5cm adj.

Code : B03715



Material: Aluminium
Adjustable leg: up to 5 cm
Thickness: 3 mm
diameter: 48 mm
Weight: 1.18 Kg



BT-STAGE-LEGCLAMP-4

Connecting clamp for four round legs

Code : B03723



Material: Steel
Thickness: 5 mm
Weight: 1.6 Kg



BT-STAGE-LEGCLAMP-2

Connecting clamp for two round legs

Code : B03722



Material: Steel
Thickness: 5 mm
Weight: 0.9 Kg



PLATFORMS



PLTL-1x1

Mobile platform 1m x 1m - 500 kg/m² - black Delivered without legs

Code : H10395



Material: Aluminium/multi-ply 12mm
Dimensions 1 x 1 m
Thickness: 55 mm
Allowable distributed load: 500 Kg/m²
Finish: Black
Weight: 12.10 Kg



PLT-j1

Junction insert

Code : H10372



Compatible with PLTL and PLTS series
Material: Steel
Thickness: 3 mm
Weight: 78 g



PLT-j2

Leveling insert

Code : H10373



Compatible with PLTL and PLTS series
Material: ABS
Weight: 11 g



PLTL-Clip

Code : H10604



PLTL series platform support clip (to be combined with PLTL-CON)



PLTL-Con

Code : H10605



PLTL series platform support junction connector (to be combined with PLTL-CLIP)

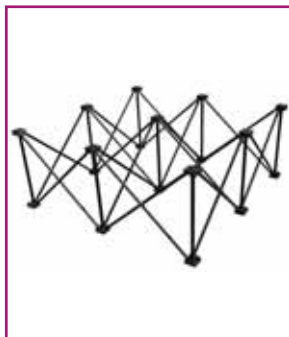

PLTL-f20

Support for mobile platform 1 x 1m - height 20cm

Code : H10396



Material: Aluminium + ABS
Finish: Black
Operating height: 20 cm
Folded height: 46.4 cm
Weight: 2.6 Kg

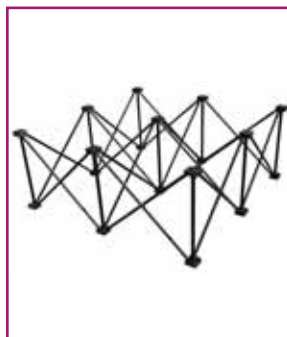

PLTL-f40

Support for mobile platform 1 x 1m - height 40cm

Code : H10397



Material: Aluminium + ABS
Finish: Black
Operating height: 40 cm
Folded height: 57.4 cm
Weight: 3.5 Kg



PLTL-f60

Support for mobile platform 1x1m - height 60cm

Code : H10398



Material: Aluminium + ABS
Finish: Black
Operating height: 60 cm
Folded height: 72.6 cm
Weight: 4.5 Kg

**BT-EASYSTAGE-1x1M**

Mobile platform 1m x 1m - 500 kg/m² - black Delivered without legs

Code : B03760

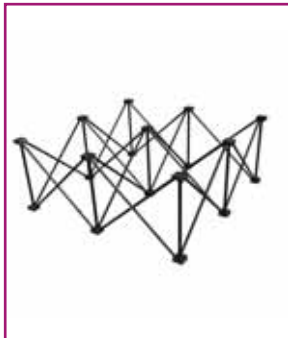

Material: Aluminium/multi-ply 12mm
Dimensions 1 x 1 m
Thickness: 55 mm
Allowable distributed load: 500 Kg/m²
Finish: Black
Weight: 12.10 Kg

**BT-EASYSTAGE-RISER-20CM**

BT-EASYSTAGE platform support 1x1m - height 20cm

Code : B03761

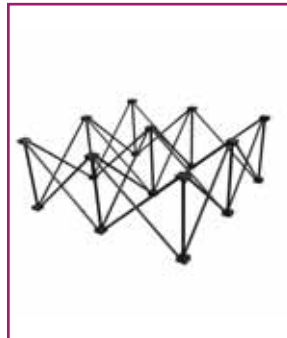

Material: Aluminium + ABS
Finish: Black
Operating height: 20 cm
Folded height: 46.4 cm
Weight: 2.6 Kg

**BT-EASYSTAGE-RISER-60CM**

BT-EASYSTAGE platform support 1x1m - height 60cm

Code : B03763



Material: Aluminium + ABS
Finish: Black
Operating height: 60 cm
Folded height: 72.6 cm
Weight: 4.5 Kg

**BT-STAGE-PLFCLAMP-SMALL (2pcs)**

Code : B03720



Material: Steel
Thickness: 3 mm
Weight: 78 g each

**BT-STAGE-PLFLEVEL (6pcs)**

Code : B03724

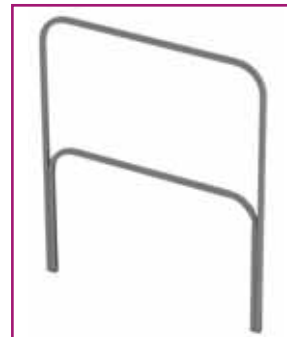

Leveling insert
Material: ABS
Weight: 11 g each

**PLTL-h1x1**

Guardrail for platform - length 1 m

Code : H10399



Material: Steel
Finish: Black
Section: 25 x 25 mm
Weight: 4.46 Kg

**PLTL-hc1**

Guardrail fastener for mobile platform - per unit

Code : H10400



Material: Steel
Finish: Grey
Weight: 0.45 Kg



PLATFORMS



PLTL-JU20x100

Finishing skirt for PLTL platform H20cm
L105cm

Code : H10469



PLTL-JU40x100

Finishing skirt for PLTL platform H40cm
L105cm

Code : H10470



PLTL-JU60x100

Finishing skirt for PLTL platform H60cm
L105cm

Code : H10471



PLTL-JU80x100

Finishing skirt for PLTL platform H80cm
L105cm

Code : H10472



PLTL-JU100x100

Finishing skirt for PLTL platform H100cm
L105cm

Code : H10473



PLTL-JU20x200

Finishing skirt for PLTL platform H20cm
L205cm

Code : H10474



PLTL-JU40x200

Finishing skirt for PLTL platform H40cm
L205cm

Code : H10475



PLTL-JU60x200

Finishing skirt for PLTL platform H60cm
L205cm

Code : H10476



PLTL-JU80x200

Finishing skirt for PLTL platform H80cm
L205cm

Code : H10477



PLTL-JU100x200

Finishing skirt for PLTL platform H100cm
L205cm

Code : H10478



PLTL-JUSUP

Fastening profile for PLTL-JU skirts L105cm

Code : H10479





BT-STAGE-PLFRAIL-1M
Guardrail for platform of 1m length Supplied with fasteners

Code : B03742



Material: Aluminium
Thickness: 2 mm
Diameter: 35 mm
Weight: 2.83 Kg
Length: 1 m
Height: 1.2 m



BT-STAGE-PLFRAIL-2M
Guardrail for platform of 2m length Supplied with fasteners

Code : B03743



Material: Aluminium
Thickness: 2 mm
Diameter: 35 mm
Weight: 3.49 Kg
Length: 2 m
Height: 1.2 m



BT-EASY STAGE-TRANSPORT 1
BT-EASYSTAGE transport tray -1x1M.

Code : B03764



Transport tray for 15 BT-EASYSTAGE platforms -1x1M
4 wheels
2 nylon straps
Weight: 25kg



FLY6PLTL1
Flight case for 6 PLTL-1x1 with legs

Code : H10430



Flight case on wheels for transporting 6 PLTL-1x1 platforms, 6 legs and accessories



BT-STAGE-TROLLEY
Platform transport trolley

Code : B03750



Transport trolley up to 20 platforms of 2m x1m
Total length: 230cm
Total height: 96cm
Weight: 46 Kg



PLT-TROLL
Platform transport trolley

Code : H10424



Transport trolley for 2x1 platforms



PLT-BOARD
Platform transport trays

Code : H10423



2 transport trays
4 braked castors per tray delivered without strap



PLATFORMS



PLT-st4060

Stairs adjustable from 0.4 m to 0.6 m - 2 steps

Code : H10383



Frames: Steel
Finish: Black
Step: 12mm multi-ply
Weight: 16.2 Kg



PLT-st60100

Stairs adjustable from 0.6 m to 1 m - 4 steps

Code : H10384



Frames: Steel
Step: 12mm multi-ply
Finish: Black
Weight: 30 Kg



PLT-st80140

Stairs adjustable from 0.8m to 1.4m - 5 steps

Code : H10404



Frames: Steel
Step: 12mm multi-ply
Finish: Black
Weight: 37.46 Kg



PLT-sth1

Guardrail for adjustable stairs

Code : H10385



Material: Aluminium
Thickness: 2 mm
Diameter: 35 mm
Weight: 3.79 Kg
Length: 2.3 m
Height: 0.76 m



BT-STAGE-STAIRS-20+40CM

Modular 2-step stairs - heights 20 and 40 cm

Code : B03740



Frames: Steel
Steps: 12mm multi-ply
Finish: Black
Weight: 20.61 Kg



BT-STAGE-STAIRS-60CM

Modular 1-step stairs - height 60 cm

Code : B03741



Frames: Steel
Step: 12mm multi-ply
Finish: Black
Weight: 12.15 Kg



BT-STAGE-STAIRS-80CM

Modular 1-step stairs - height 80 cm

Code : B03744



Frames: Steel
Step: 12mm multi-ply
Finish: Black
Weight: 13.46 Kg



BT-STAGE-STAIRS-RAIL3

Guardrail for stairs

Code : B03745



Material: Aluminium
Thickness: 2 mm
Diameter: 35 mm
Weight: 3.4 Kg
Length: 228.5 cm
Support included



PLT-stm20

Modular 1-step stairs - height 20 cm

Code : H10386



Frames: Steel
 Step: 12mm multi-ply
 Finish: Black
 Weight: 9.61 Kg



PLT-stm40

Modular 2-step stairs - heights 20 and 40 cm

Code : H10387



Frames: Steel
 Steps: 12mm multi-ply
 Finish: Black
 Weight: 20.61 Kg



PLT-stm60

Modular 1-step stairs - height 60 cm

Code : H10388



Frames: Steel
 Step: 12mm multi-ply
 Finish: Black
 Weight: 12.15 Kg



PLT-stm80

Modular 1-step stairs - height 80 cm

Code : H10389



Frames: Steel
 Step: 12mm multi-ply
 Finish: Black
 Weight: 13.46 Kg



PLT-sth2

Guardrail for modular stairs - length 140cm

Code : H10390



Material: Aluminium
 Thickness: 2 mm
 Diameter: 35 mm
 Weight: 3.4 Kg





Hilec

LIGHT & SOUND ACCESSORIES

Premium Series

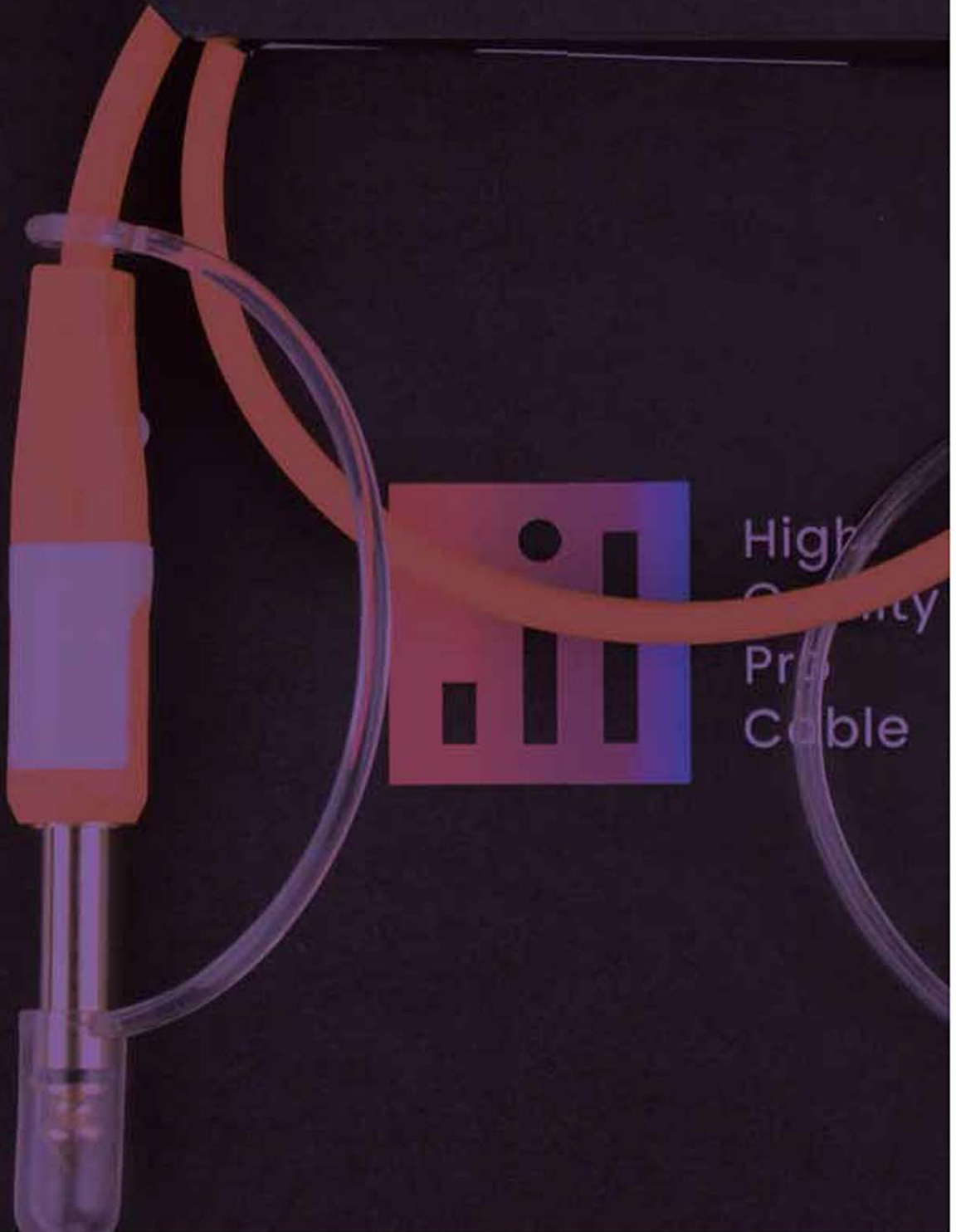

High
Quality
Pro
Cable

ACCESSORIES

LIGHTING STANDS AND LIGHT BRIDGE
SPEAKER AND MICROPHONES STANDS
MICROPHONE ACCESSORIES STANDS
WALL BRACKETS
PROTECTIVE COVERS
BATTERIES
GAFFAS
COLOURING
GOOSENECK LIGHTS
LINE AUDIO CABLES
MICROPHONE CABLES
SPEAKER CABLES
HYBRID AUDIO CABLES
DMX LIGHTING CABLES
HYBRID LIGHTING CABLES
POWER CABLES
USB CABLES
VIDEO CABLES
AUDIO CABLE
LIGHTING CABLE
ELECTRICAL CABLE

NEUTRIK CONNECTORS
CONNECTORS
ADAPTERS
ELECTRICAL CONNECTORS
CONSTRUCTION ACCESSORIES
LOUDSPEAKERS AND FILTERS
LAMPS



STANDS AND LIGHT BRIDGES



POT-330

Light bridge with steel structure
Length: 3.00 m Height: 3.20 m

Code : H8259



Net weight: 21.6 Kg
Light bridge height: 1.49 to 3,18 m
Light bridge width:
3 m (2x 1.5 m trusses)
Number of holes: 10
Supported load: 80 Kg distributed
Dimension of each stand on the ground:
1.2 m
Diameter of the stand tubes: 28 mm
Materials:
- Steel
- ABS for the wheels
Finish: matte black epoxy paint

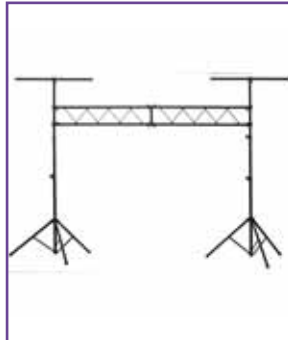

LB-30

Light bridge: 2stand+truss,
H3.25m - B4.2m -100kg

Code : B00755



Multifunctional aluminium economical bridge
Consisting of 2 stands with T-bar and 2 bridge elements
The 2 stands with T-bar can be used separately!
Perfect for the mobile DJ: can be stored in any type of car!
Distributed load up to 100kg!
Distance between the stands = 3m
Total width with installed T-bars = 4.2m
Maximum height = 3.25m



PID-100

Robust double crossbar stand, all-metal
Height 3 m ø28

Code : H8252



Net weight: 5.3 Kg
Height: from 1.48 to 3.13m
Folded height: 1.23 m
Tripod diameter: 1.4 m
Supported load: 30 Kg
Final tube diameter: 28 mm
Tripod with double crossbars
Materials:
- Steel for tubes, tripod and crossbars
- Rubber for the ends of the tubes
- ABS for the knobs
Finish: matte black epoxy paint



PID-240

Stand + all-metal bar Height 2.40 m ø28

Code : H8253



Net weight: 6.7 Kg
Height: from 1.49 to 2.40 m
Folded height: 1.23 m
Tripod diameter: 1.2 m
Supported load: 30 Kg
Diameter of the final tube: 28 mm
Horizontal bar length: 1 m
Single crossbar tripod
Materials:
- Steel for tubes, tripod and cross
- Rubber for the ends of tubes
- ABS for the knobs
Finish: matte black epoxy paint



LST-32

Light stand + T-bar, extendable - H3.18m/
B1.5m/30kg

Code : B00756



Very stable folding lighting bracket with 100cm T-bar
Robust design with 3 telescopic steel sections.
Perfect for mounting all kinds of projectors and small lighting effects
Maximum load: 30kg
Net weight: 6.53 Kg
Max. height: 3.18 m



PID-380

3m stand with bar and maximum load of 80 kg

Code : H10489



Net weight: 11.2 Kg
Height: from 1.87 to 3 m
Folded height: 1.59 m
Tripod diameter: 1.3 m
Supported load: 80 Kg
Diameter of the final tube: 35 mm
Length of the horizontal bar: 1.5 m
Horizontal bar diameter: 35 mm
Tripod with double crossbars
Materials:
- Steel for tubes, tripod and crossbars
- Rubber for the ends of tubes
- ABS for the knobs
Finish: matte black epoxy paint



LS-64

Lighting stand - 3.10m / 80kg

Code : B00732



FLOOR4

Projector floor stand with M10 screw

Code : H9666



PROJECTOR FLOOR STAND

Projector floor stand with M10 screw

Code : B04947



Multifunctional professional stand can be used as speaker stand or lighting stand
Can be used as lighting stand with the TB-66 bar, available as an option.
Max. load: 80kg



PID1-BAG

Code : H10012

Customized for PID-100 and PID-240 stands
Maximum diameter: 16 cm
Maximum height: 125 cm



PID2-BAG

Code : H10013

Customized for PID-100 and PID-240 stand
Maximum diameter: 20 cm
Maximum height: 125 cm



BRE-120

Code : H8256

Internal diameter of the stand adaptor: 28 mm
Bar length: 1.20 m
Bar section: 30 x 30 mm
Number of holes: 4
Materials: Steel and ABS for the knob
Finish: matte black epoxy paint
Net weight: 1.6 Kg



BRE-50

Code : H8845

Length: 1.5 m / round section: 50 mm
Stand adaptor for 35 mm stands
Weight: 3.6 kg



TB-66

Code : B00733

T-Bar for LS-64
Mounting of up to 12 projectors
Equipped with fixing hardware
Length = 150cm
Designed for mounting on standard 35mm mast top



TB-64

Code : B00743

Steel T-Bar (30x30mm)
Mounting up to 8 projectors
Equipped with fixing hardware
Length = 120cm
Planned for mounting on standard 35mm mast top



T 150

Code : B02616

Truss adaptor for 150mm truss
Suitable for all our stands that have a ø35mm mast top



DJ-TRUSS 200

Code : B00739

Very strong and compact steel truss, section 150
Length = 2m



DJ-TRUSS 150

Code : B00740

Very strong and compact steel truss, section 150
Length = 1.5m



SST-20

Code : H8262

For PT20-150 truss only
Bar length: 21 cm
Section of the bar: 30 x 20 mm
Internal diameter of the stand adaptor: 28 mm
M8 screw for fastening the truss
Finish: matte black epoxy paint
Weight: 0.40 Kg



NEW

SST-22

Code : H10873

Stand adaptor with 35mm tube for 220 truss



SPEAKER STANDS



SS-AIR

Speaker stand, expandable pneumatic brake - 1.80m / 60kg

Code : B00734



Professional aluminium speaker stand, equipped with a special air cushion system!
To avoid any accident, the speaker goes down slowly instead of "falling" on its base
Very stable construction with metal base
Low minimum height: facilitates placement of the speaker on the stand!
Max load: 60kg



CAB-200

All-metal speaker stand Height 2 m

Code : H8245



Net weight: 4.5 Kg
Height: from 1.41 to 2.10 m
Folded height: 1.08 m
Tripod diameter: 1.2 m
Supported load: 40Kg
Diameter of the final tube: 35 mm
Tripod with single crossbars
Materials:
Steel for tubes and tripod
Rubber for the ends of tubes
ABS for the knobs
Finish: matte black epoxy paint



SS-59

Speaker stand, extendable - 2.05m / 40kg

Code : B00737



Professional speaker stand
Very stable construction with metal base
Low minimum height: facilitates placement of the speaker on the stand
Max load: 40kg



TUB-LINK

83 to 123cm telescopic pole with pin

Code : H9105



Telescopic pole
Diameter of the upper part: 35mm
Diameter of the lower part: 35mm
Height: 83 cm to 123 cm
Load capacity: 30kg



SPEAKER POLE (M20 thread)

Telescopic pole

Code : B00659



Telescopic pole
Diameter of the upper part: 35mm
Bottom thread: 20mm
Height: 76 cm to 1.16 m
Load capacity: 30kg



VP-130

Telescopic pole

Code : B00655



This special stand offers you the possibility to place a speaker from 0.7m to 1.3m



TWIN SPEAKER BRACKET Mk2

Adapter for 2 speakers on one stand

Code : B00763



Adapter for installing 2 speakers on a single stand.
The distance between the speakers can be adjusted between 32 and 51cm.
Solid steel construction.
For speakers up to 2x 20kg
Adapter diameter: D=35mm



FORK

Separate 42 cm double 35mm adapter for speakers up to 40Kg

Code : H7916



Adapter for the installation of 2 speakers on a single stand.
Distance between speakers: 42cm.
Solid steel construction.
For speakers up to 40 Kg
Diameter of the adapter: D=35mm



CAB1-BAG

Bag for 1 speaker stand

Code : H10010



Customized for Audiophony CAB-100 and CAB-200 stands
Adjustable strap
Maximum diameter: 16 cm
Maximum height: 110 cm



CAB2-BAG

Bag for 2 speaker stands

Code : H10011



Customized for Audiophony CAB-100 and CAB-200 stands
Divider
Adjustable strap
Maximum diameter: 20 cm
Maximum height: 110 cm



BAG-STAND

Nylon bag for stands intended for lighting effects or sound system elements

Code : B00741



Stylish and durable nylon bag for stands intended for lighting effects or sound system elements
Perfect for SS-59, SS-AIR, LST-32 stands



MICROPHONE STANDS



MIC-200T

Microphone stand with telescopic boom with heavy baseplate - adjustable height

Code : H8236



Microphone stand with telescopic boom with heavy baseplate
 Net weight: 5.3 Kg
 Height: from 92 cm to 1.52 m
 Baseplate diameter: 25.5 cm
 Thread at the boom tip: 3/8"
 Boom length: 55 to 90 cm
 Materials:
 - Aluminium for the boom hinge
 - Steel for the tubes and baseplate
 - Rubber for the ends of tubes
 - ABS for the knobs and the boom tip
 Finish: matte black epoxy paint



MIC-100

All-metal microphone boom tripod with adjustable height

Code : H8235



Net weight: 2.9 Kg
 Height: from 1.05 to 1.60 m
 Tripod diameter: 72 cm
 Thread at the end of the pole: 3/8"
 Boom length: 74 cm
 Materials:
 - Aluminium for the tripod and boom hinge
 - Steel for the tubes
 - Rubber for the ends of tubes
 - ABS for the knobs and the pole tip
 Finish: matte black epoxy paint



MS-26PRO

Adjustable height all-metal pole tripod

Code : B00765



Professional microphone stand with adjustable boom
 Robust and resistant magnesium base
 Very good stability
 Boom length: 64cm
 Thread at the end of the pole: 3/8"



MIS10

Microphone stand + bag

Code : H10068



STAND
 Net weight: 1.8 Kg
 Height: from 95 cm to 1,48 m
 Tripod diameter: 70 cm
 Thread at the end of the pole: 3/8"
 Length of the pole: 77 cm
 Materials:
 - ABS for the tripod and boom hinge
 - Steel for tubes
 - Rubber for the ends of tubes
 - ABS for the knobs and the pole tip
 Finish: matte black epoxy paint
 COVER
 Slide-fastener (zipper)
 Material: Polyester
 Customized for Audiophony MIC-100T and MIS10 microphone stands
 Maximum diameter: 10 cm
 Maximum height: 110 cm



MS-27

Straight universal microphone stand

Code : B00766



Straight universal microphone stand
 Base in thick cast iron, covered with a beautiful layer of plastic.
 Base diameter: 25cm
 Thread at the end of the pole: 3/8"



MS-25

Adjustable height all-metal pole tripod

Code : B00764



Microphone stand with adjustable swivel boom
 Solid nylon base
 Very good stability
 Pole length: 64cm
 Thread at the end of the pole: 3/8"



MIC5-BAG

Bag for 5 microphone stands

Code : H10009



Customized for the Audiophony MIC-100 stand
 5 separate spaces
 Lateral strap
 Max. diameter of each space: 10 cm
 Height of each space: 100 cm
 28 cm flap



MIC1-BAG

Bag for 1 microphone stand

Code : H10008



Customized for the Audiophony MIC-100 stand
 Side handle
 Maximum diameter: 10 cm
 Maximum height: 104 cm



BAG-MIC

Nylon bag for microphone stand

Code : B00742



Stylish and durable nylon bag for microphone stand
Perfect for MS-25 and MS-26PRO stands

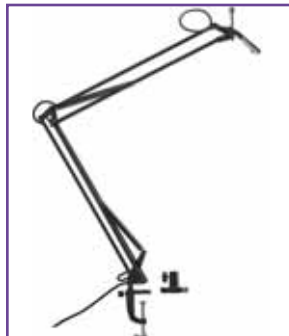

TMIC100

Flexible arm for microphone with XLR cable and table mounting

Code : H10458



TMIC-20

Microphone table stand with heavy base - height 30 cm

Code : H8232



Net weight: 3,3 Kg
Height: 30 cm
Diameter of the base: 22 cm
Thread at the end of the pole: 3/8"
Length of the pole: 74 cm
Materials:
Steel
Rubber on the base
ABS for the knob and the boom tip
Finish: matte black epoxy paint



JB50

Microphone table stand with heavy base - microphone thread : 3/8"

Code : B00702



Microphone table stand
Heavy base
Robust design
Telescopic microphone arm:
Min. length: 320mm
Max. length: 565mm



TMIC-10

Microphone table stand - height 18 cm

Code : H8231



Net weight: 0.24 Kg
Height: 18 cm
Tripod diameter: 26 cm
Thread at the end of the pole: 3/8"
Materials:
Steel
Rubber for the ends of tubes
Finish: matte black epoxy paint



JB52

Microphone table stand, thread: 3/8"

Code : B00700



Microphone table stand.
Innovative design, fully foldable.
thread: 3/8"
Height: 170mm



JB55

Straight table base for microphone

Code : B00704



Straight table base (24 cm to 40 cm)



JB85

Gooseneck 50cm for microphones

Code : B00709



Flexible gooseneck, length 50 cm



JB88

Base for gooseneck (JB85)

Code : B00710



MICROPHONE ACCESSORIES



JB70
Universal clamp for quick-attaching microphone

Code : B00707



Universal clamp for quick-attaching microphone



JB71
Universal clamp for microphone

Code : B00412



Universal clamp for micro
Soft material: does not scratch



A415
Spring microphone clamp

Code : H0180



Material: ABS
Maximum opening diameter: 40mm



A602
Insert microphone clamp

Code : H1078



Material: Rubber
Supplied with 3/8 to 5/8 insert



PM38
3/8 rubber microphone clamp

Code : H9929



Material: Rubber
3/8 brass insert



AD38
Microphone clamp adapter 3/8 to 5/8

Code : H9930



JB75
Metal reduction 5/8 "-3/8" (10 pieces)

Code : B00711

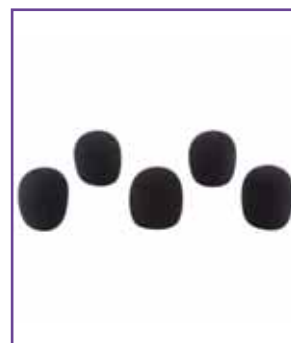

WINDSCREEN BLACK
Set of 5 black foams.

Code : B00415



WINDSCREEN COLOURED
Set of 5 foams in different colors.

Code : B00416



WS-3
Black microphone windscreen

Code : H3686



STANDS



KB4

Keyboard stand with double crossbars - Magnesium series

Code : H9663



Net weight: 4.5 Kg
 Height: from 58 to 98 cm
 Width: from 80 to 82 cm
 Length of the upper tubes: 40 cm
 Supported load: 50 Kg max.
 Locking brake
 Materials:
 - Steel for the tubes and bars
 - Rubber for the ends of tubes
 Finish: anthracite epoxy paint



KB-UNO

Keyboard stand

Code : H8226



Net weight: 2.2 Kg
 Height: from 60 cm to 93 cm
 Distance of horizontal crossbars: from 32 cm to 80 cm
 Crossbar length: 30 cm
 Materials:
 - Steel for the stand
 - Rubber for the ends of tubes
 Maximum load: 25 Kg
 Finish: matte black epoxy paint



KB-ROLL

Controller or keyboard stand with integrated trolley.

Code : H8224



Net weight: 6.1 Kg
 Height: from 60 cm to 120 cm
 Distance of horizontal crossbar: from 32 cm to 87 cm
 Length of crossbar: 40 cm
 Materials:
 - Steel for the stand
 - ABS for retractable bars
 - Rubber for the ends of tubes
 - Nylon for the strap
 Maximum load: 50 Kg
 Finish: matte black epoxy paint



KB-BAG

Bag for 1 controller or keyboard stand

Code : H10007



Customized for Audiophony KB-ROLL, KB-UNO and KB4 stands
 Side handle
 Maximum width: 50 cm
 Maximum height: 100 cm
 Maximum thickness of the folded stand: 5 cm



KB-EXT70

Extension for control stand - inclined

Code : H8227



Net weight: 1.5 Kg
 Height: 24 cm
 Crossbar incline: 70° compared to the vertical
 Crossbar length: 30 cm
 Materials:
 - Steel for the stand
 - ABS for the knob
 - Rubber for the ends of tubes
 Finish: matte black epoxy paint



KB-EXT90

Extension for control stand - straight

Code : H8228



Net weight: 1.5 Kg
 Height: 24 cm
 Crossbar incline: horizontal
 Length of the traverse: 30 cm
 Materials:
 - Steel for the support
 - ABS for the knob
 - Rubber for the ends of tubes
 Finish: matte black epoxy paint



DJ4

Magnesium series DJ control stand

Code : H9665



Net weight: 15 Kg
 Height: from 68 to 92 cm
 Dimensions of the main tray: 45 x 100 cm
 Dimensions of the top tray: 30 x 60 cm
 Materials:
 - Steel for the tubes, bars and trays
 - ABS for tube tips and knobs
 Finish: anthracite epoxy paint



SUPPORTS



MEDIAstage1

Aluminium stand for mobile phones

Code : H10495



For 3.5 to 5.5 inch phones
 Material: Aluminium
 Dimensions (WxHxD): 38 x 381 x 25 mm
 Folded dimensions (WxHxD):
 38 x 168 x 25 mm
 Arm length (unfolded): 238 mm
 Stand depth: 17,5 mm
 Stand height: 57 to 89 mm
 Weight: 130 grams



MEDIAstage2

Aluminium stand with clamp for mobile phones and tablets

Code : H10496



Suitable for smartphones and tablets from 4 to 11 inches
 Aluminium structure, 500g
 Maximum load 1 kg



MEDIAstage3

Aluminium stand with 1 suction cup for tablets and smartphones

Code : H10494



Suitable for smartphones and tablets from 4 to 11 inches
 Aluminium structure, 500g
 Maximum load 1 kg



MEDIAstage4

Aluminium stand with double suction cups for tablets and smartphones

Code : H10493



Suitable for smartphones and tablets from 4 to 11 inches
 Aluminium structure, 500g
 Maximum load 1 kg



MEDIAstage5

Aluminium stand with 1 suction cup for mobile phones and tablets

Code : H10654



MEDIAstage6

Aluminium stand for mobile phones and tablets

Code : H10655



MEDIA2

Tablet holder to attach to microphone stand

Code : H10457



TABLET HOLDER

Universal tablet holder for microphone stand. Screens from 7" to 11"

Code : B00767





LAPTOP STAND
Universal computer stand

Code : B03195



MEDIA4
Magnesium series adjustable multimedia stand

Code : H9664



MEDIA3
Laptop stand with table mounts

Code : H10456



Universal laptop stand
Easily attaches to the vertical parts of your flight bag
Easily attaches to a table
Adaptable in many ways, thanks to intelligent design:
Adaptable width, thanks to 4 expansion adapters: 235mm to 285mm
Adaptable height: 250mm to 380mm
Durable and stable metal design in black finish.
All accessories (buttons, table/rack clamps, extension adapter) are included.
Weight: 2.3kg (all included)
Max. height: 380mm
Minimum height: 250mm
Max. width: 285mm
Min. width: 235mm

Net weight: 2.8 Kg
Height: from 17 to 30 cm
Width (from the top): from 29 to 39 cm
Materials:
- Steel
- ABS for the knobs and bar tips
Finish: anthracite epoxy paint



A	SUPPLAT Code : H7903	Plastic support plate for 36 mm stand Platinum 180 x 120 mm		B	EYE-10 Code : H8843	Eyebolt without M10 screws - 230 Kg	
C	EYE-08 Code : H8842	Eyebolt without M8 screws - 140 Kg		D	M10 Eyebolt (4 pcs) Code : B00658	Eyebolt without M10 screws (4 pcs)	
E	M8 Eyebolt (4 pcs) Code : B00657	Eyebolt without M8 screws (4 pcs)		F	H00K-12 Code : H8844	Harp shackle 12 mm - 500 Kg	
G	CPL-35 Code : H8248	Cup with M8 screw for 35 mm stand		H	C-35 Code : H8247	Metal speaker baseplate	
I	C-36 Code : H1077	Metal speaker base		J	CPL-12 Code : H3239	Super reinforced cup Diameter 12 cm	
K	CO-12 Code : B02645	Reinforced cup ø12cm.		L	CPL-28 Code : H8255	Cup with M8 screw For 28 mm stand	
M	VELCRO-30 Code : H8876	VELCRO 25 x 300 mm strap		N	VELCRO-60 Code : H8877	VELCRO 45 x 600 mm strip	
O	COLL520 Code : H10442	Reusable clamping collar 48x200mm-100 pieces		P	COLL825 Code : H10443	Reusable clamping collar 76x250 mm-100 pieces	



WALL BRACKETS



A	SUPWALL Code : H9104	Adjustable wall mount for speakers up to 40Kg
C	BS/6-1 Code : H7906	Adjustable wall mount for speakers up to 20kg
E	WB-L30 Code : B00761	Wall mount 30cm, 40kg
G	iLINE24sup Code : H10773	Adjustable wall bracket for iLINE23 and iLINE43
I	iLINEbase Code : H10760	Floor bracket for iLINE83B and iLINESPACE60
K	iLINE43sup Code : H10755	Wall bracket for iLINE43 column
M	iLINE24sup Code : H10773	Adjustable wall bracket for iLINE23 and iLINE43
O	CUB-Wall1 Code : H10730	Wall bracket for CUBsat4
Q	CUB-Truss1 Code : H10732	Suspension support for CUBsat4
S	SUP-AC08WH Code : H9599	ACUTE08 monitor hanging bracket - white
U	SUPS6/WH Code : H9706	Mounting bracket for S6 satellite - white
W	SUPS8/WH Code : H9708	Mounting bracket for S8 satellite - white
Y	SUPS10/WH Code : H9710	Mounting bracket for S10 satellite - white
A1	Bracket for SC-12 Code : B09185	Robust Foldable Stand for SC-12 Speaker

B	BS/5-1 Code : H7907	Articulated wall baseplate for large speakers up to 40 Kg
D	WB-L20 Code : B00760	Wall mount 20cm, 40kg
F	BYR Code : H1075	Wall mount for rotating speaker
H	iLINEspace60 Code : H10759	Increase height by 60cm for iLINE83B with stackable connector base
J	iLINE83sup Code : H10757	Wall bracket for iLINE83 column
L	iLINE23sup Code : H10753	Wall bracket for iLINE23 column
N	CUB-BRACKET Code : H10666	Bumper suspension for mini line array head
P	CUB-Pole1 Code : H10731	Foot support for CUBsat4
R	SUP-AC08NO Code : H9598	ACUTE08 monitor hanging bracket - black
T	SUPS6/NO Code : H9705	Hanging bracket for S6 satellite - black
V	SUPS8/NO Code : H9707	Mounting bracket for S8 satellite - black
X	SUPS10/NO Code : H9709	Mounting bracket for S10 satellite - black
Z	Bracket for SC-08 Code : B09184	Robust foldable stand for SC-08 speaker
B1	Bracket for SC-15 Code : B09186	Robust Foldable Stand for SC-15 Speaker

PROTECTIVE COVERS



A	COV-MOJ0500LINE Code : H10867	Protective cover for MOJ0500LINE subwoofer
C	COV-SX15A Code : H10855	Protective bag for SX15A
E	iLINEcov Code : H10768	Protective bag for iLINE series subwoofers
G	COV-ATOM12A Code : H10785	Protective bag for ATOM12A
I	COV-ATOM15ASUB Code : H10787	Protective bag for ATOM15ASUB
K	COV-SR15 Code : H10169	Bag for SR15A speaker
M	COV-SR10 Code : H10167	Bag for SR10A speaker
O	COV-MOJ01000FX Code : H10350	Travel bag + trolley for MOJ01000FX
Q	COV-CR25A Code : H10791	Protective bag for CR25A-COMBO
S	COV-CR80A Code : H10431	Bag for CR80A-COMBO loudspeaker
U	COV-CROSS Code : H9985	Carrying bag for CROSSER loudspeakers
W	TOURING BAG Code : B00597	Carrying bag for PS-15/PSA-15
Y	TOURING BAG - Vibe 15 Code : B00592	Carrying bag for Vibe 15
A1	TOURING BAG - Vibe 18 SUB Code : B00595	Carrying Bag for Vibe 18 SUB!!!!
C1	COV-SRSUB18A Code : H10887	Bag for COV-SRSUB18A subwoofer

B	COV-SX12A Code : H10854	Protective bag for SX12A
D	iLINEbag Code : H10767	Carrying bag for 2 iLINE 8 HP columns or 2 iLINEspace 60
F	COV-ATOM10A Code : H10784	Protective bag for ATOM10A
H	COV-ATOM15A Code : H10786	Protective bag for ATOM15A
J	COV-ATOM18ASUB Code : H10788	Protective bag for ATOM18ASUB
L	COV-SR12 Code : H10168	Bag for SR12A speaker
N	COV-SRSUB15A Code : H10351	Protective bag for SRSUB15A subwoofer
P	COV-BOOMBOX Code : H10488	Carrying bag for BOOMBOX
R	COV-CR12A Code : H10208	Bag for CR12A-COMBO loudspeaker
T	COV-SPRINT Code : H9986	Carrying bag for SPRINTER loudspeakers
V	TOURING BAG - PS-12/PSA-12 Code : B00596	Protective cover for PS-12, PSA-12, PPA-121
X	TOURING BAG - Vibe 12 Code : B00591	Carrying bag for Vibe 12
Z	TOURING BAG - Vibe 15 SUB !!!! Code : B00594	Carrying bag for Vibe 15 SUB!!!!
B1	TOURING BAG - Vibe 30 Code : B00593	Carrying bag for Vibe 30



BATTERIES



A	PILE-LR03	Blister alkaline battery 4 x 1.5 V	Code : H8147
B	PILE-LR06	Blister alkaline battery 4 x 1.5 V	Code : H8148
C	PILE-6LR61	Blister alkaline battery 1 x 9 V	Code : H8146
D	PILE-VI-6LR61	VARTA INDUSTRIAL 9V battery (in blister of 20)	Code : H10743
E	PILE-VI-LR6	VARTA INDUSTRIAL 1.5V LR6 battery (in blister of 10)	Code : H10744
F	PILE-VI-LR3	VARTA INDUSTRIAL 1.5V LR3 battery (in blister of 10)	Code : H10745
G	PILE-VCR2025	VARTA CR2025 button battery (in blister of 10)	Code : H10746

















GAFFAS



D	GAFFA-PRO/NO	Gaffa 50mm x 50m professional black	Code : H3956
E	GAFFA-PRO/WH	Roll of 50 m x 5 cm canvas - White	Code : H8874
F	GAFFA-PRO/GR	Roll of 50m x 5cm canvas - Grey	Code : H8875
G	GAFFER TAPE MATT 50 BLACK	High quality matt black canvas tape of 50m x 5 cm.	Code : B06104
H	GAFFER TAPE STD 25 WHITE	High quality white tape 50m x 25mm.	Code : B06103
I	GAFFER TAPE STD 50 BLACK	High quality black canvas tape 50m x 5 cm.	Code : B06100
J	GAFFER TAPE STD 50 GREY	High-quality grey canvas tape 50m x 5 cm.	Code : B06101
K	GAFFER TAPE STD 50 WHITE	High-quality white canvas tape 50m x 5 cm.	Code : B06102

COLOURING



A	COLOR FILTER Sheet «Congo Blue 181”	1.22 x 0.53m "Congo Blue 181" colour sheet	Code : B04564	
B	COLOR FILTER Sheet «Dark Green 124”	1.22 x 0.53m "Dark Green 124" colour sheet	Code : B04566	
C	COLOR FILTER Sheet «Magenta 113”	1.22 x 0.53m "Magenta 113" colour sheet	Code : B04567	
D	COLOR FILTER Sheet «Mauve 126”	1.22 x 0.53m "Mauve 126" colour sheet	Code : B04569	
E	COLOR FILTER Sheet «Medium Blue-Green”	1.22 x 0.53m "Medium Blue-Green" colour sheet	Code : B04568	
F	COLOR FILTER Sheet «Orange 105”	1.22 x 0.53m "Orange 105" colour sheet	Code : B04561	
G	COLOR FILTER Sheet «Primary Green 139”	1.22 x 0.53m "Primary Green 139" colour sheet	Code : B04565	
H	COLOR FILTER Sheet «Primary Red 106”	1.22 x 0.53m "Primary Red 106" colour sheet	Code : B04562	
I	COLOR FILTER Sheet «Sky Blue 068”	1.22 x 0.53m "Sky Blue 068" colour sheet	Code : B04563	
J	COLOR FILTER Sheet «Vanity Fair 793”	1.22 x 0.53m "Vanity Fair 793" colour sheet	Code : B04570	
K	COLOR FILTER Sheet «Yellow 101”	1.22 x 0.53m "Yellow 101" colour sheet	Code : B04560	
L	FILTER SHEETS PAR56 PRO- 10 col.	Set of filters, 10 different colours	Code : B04553	
M	FILTER SHEETS PAR56 PRO- 5 col.	Set of filters, 5 different colours	Code : B04552	
N	FILTER SHEETS PAR56 SH - 10 col.	Set of filters, 10 different colours	Code : B04551	
O	FILTER SHEETS PAR56 SH - 5 col.	Set of filters, 5 different colours	Code : B04550	
P	FILTER SHEETS PAR64 PRO- 10 col.	Set of filters, 10 different colours	Code : B04555	
Q	FILTER SHEETS PAR64 PRO- 5 col.	Set of filters, 5 different colours	Code : B04554	



GOOSENECK LIGHTS



Hilec
LIGHT & SOUND ACCESSORIES

A	Snake16USB	Flexible lamp with 6 white COB LEDs - USB	Code : H10802
B	Snake16	1-arm desk lamp with 6 white COB LEDs	Code : H10803
C	Snake23DUO	2-arm desk lamp with 3 white COB LEDs	Code : H10804
D	Snake118DeskW	Desk lamp with 18 warm white COB LEDs	Code : H10805
E	Snake118DeskC	Desk lamp with 18 cool white COB LEDs	Code : H10806
F	Snake16M	Flexible LED lamp + magnetic baseplate + Battery	Code : H10807
G	Snake26Rack	2-arm USB rack light with white LEDs	Code : H10808
H	Snake16RGBUSB	Flexible lamp with 6 RGB COB LEDs - USB	Code : H10809
I	COB LED CLIP LIGHT WW	Very powerful 30cm flexible gooseneck lamp with clip	Code : B00226
J	COB LED MINILIGHT WW	Very powerful 30cm flexible gooseneck lamp	Code : B00224
K	COB LED RACKLIGHT WW	Very powerful 30cm flexible gooseneck lamp for rack	Code : B00227

LINE AUDIO CABLES



A	CFLAT-XXMF/0.5 Code : H10810	XLR male / XLR female flat cable - 0.5m	K	CL-41/1.5 Code : H10674	2 x XLR male / 2 x stereo male jack cable - 1.5m
	CFLAT-XXMF/1 Code : H10811	XLR female / XLR male flat cable - 1m		CL-41/3 Code : H10675	2 x XLR male / 2 x stereo male jack cable - 3m
	CFLAT-XXMF/1.5 Code : H10812	XLR female / XLR male flat cord - 1.5m	L	CL-42/1.5 Code : H10676	2 x XLR female / 2 x mono male jack cable - 1.5m
B	CFLAT-JSJS/0.5 Code : H10813	TRS jack / TRS jack flat cable - 0.5m		CL-42/3 Code : H10677	2 x XLR female / 2 x mono male jack cable - 3m
	CFLAT-JSJS/1 Code : H10814	TRS jack / TRS jack flat cable - 1m	M	CL-43/1.5 Code : H10678	2 x XLR female / 2 x stereo male jack cable - 1.5m
	CFLAT-JSJS/1.5 Code : H10815	Jack TRS / Jack TRS flat cord - 1.5m		CL-43/3 Code : H10679	2 x XLR female / 2 x stereo male jack cable - 3m
C	CFLAT-JSXF/0.5 Code : H10816	TRS Male / XLR Female 6.35 jack flat cable - 0.5m	N	CL-2XM2XF/0.6 Code : H10680	2 x XLR Male / 2 x XLR Female cable - 0.6m
	CFLAT-JSXF/1 Code : H10817	TRS Male / XLR Female 6.35 jack flat cable - 1m		CL-2XM2XF/1.5 Code : H10681	2 x XLR female / 2 x XLR Male cable - 1.5m
	CFLAT-JSXF/1.5 Code : H10818	XLR Female / Jack 6.35 TRS Male flat cord - 1.5m		CL-2XM2XF/3 Code : H10682	2 x XLR Male / 2 x XLR female cable - 3m
D	CFLAT-JSXM/0.5 Code : H10819	TRS Male / XLR Male 6.35 jack flat cable - 0.5m		CL-2XM2XF/6 Code : H10683	2 x XLR Male / 2 x XLR female cable - 6m
	CFLAT-JSXM/1 Code : H10820	TRS Male / XLR Male 6.35 jack flat cable - 1m	O	ADAPT2010 Code : H10697	Female / 2 x RCA male 3.5 jack cable
	CFLAT-JSXM/1.5 Code : H10821	XLR Male / Jack 6.35 TRS Male flat cord - 1.5m	P	ADAPT2020 Code : H10698	1 stereo male 3.5 jack / 2 stereo female 3.5 jack cable - Black
E	CFLAT-RCA/0.5 Code : H10822	RCA male / RCA male flat cable - 0.5m	Q	CL-05/1.5 Code : H7976	Male 6mm jack / Mono male jack line cable - 1.5m
	CFLAT-RCA/1 Code : H10823	RCA male / RCA male flat cable - 1m		CL-05/3 Code : H7977	Male 6mm jack / Mono male jack line cable - 3m
	CFLAT-RCA/1.5 Code : H10824	RCA male / RCA male flat cord - 1.5m		CL-05/6 Code : H7978	Male 6mm jack / Mono male jack line cable - 6m
F	CFLAT-JMJM/0.5 Code : H10825	6.35 J mono / 6.35 J mono flat cable - 0.5		CL-05/10 Code : H7979	Male 6mm jack / Mono male jack line cable - 10m
	CFLAT-JMJM/1 Code : H10826	Mono 6.35 jack / mono 6.35 jack flat cable - 1	R	CL/JMJM-1,5 Code : H7980	Male jack / Mono male jack line cable - 1.5m
	CFLAT-JMJM/1.5 Code : H10827	J 6.35 Mono / J 6.35 mono flat cord - 1.5		CL/JMJM-3 Code : H7981	Male jack / Mono male jack line cable - 3m
G	CL-32/1.5 Code : H10668	Stereo / 2 x XLR male 3.5 jack cable - 1.5m		CL/JMJM-6 Code : H7982	Male jack / Mono male jack line cable - 6m
	CL-32/3 Code : H10669	Stereo / 2 x XLR male 3.5 jack cable - 3m		CL/JMJM-10 Code : H7983	Male jack / Mono male jack line cable - 10m
H	CL-28/0.6 Code : H10670	1 XLR female / 2 x XLR male cable - 0.6m		CL/JMJM-20 Code : H7984	Male jack / Mono male jack line cable - 20m
I	CL-29/0.6 Code : H10671	1 XLR male / 2 x XLR female cable - 0.6m			
J	CL-40/1.5 Code : H10672	2 x mono 6.35 jack / 2 x XLR male cable - 1.5m			
	CL-40/3 Code : H10673	2 x mono 6.35 jack / 2 x XLR male cable - 3m			



LINE AUDIO CABLES

tasker



A	PRE-DPR-RF311black Code : B01050	MF114ZW01 - Signal de câble assemblé, C11
C	PRE-DPR-RF315black Code : B01052	MF114ZW05 - Signal de câble assemblé, C11
E	PRE-DPR-RF3120black Code : B01054	MF114ZW20 - Signal de câble assemblé, C1
G	PRE-DPR-RF335black Code : B01061	MF128ZW05 - Signal de câble assemblé, C12
I	PRE-DPR-RF3320black Code : B01063	MF128ZW20 - Signal de câble assemblé, C1
J	RF143 Code : B01000	Signal de câble assemblé, C114bl+NP2C/NP2C 3m
L	RF149 Code : B01002	Signal de câble assemblé, C114bl+NP2C/NP2C 9m
N	RF213 Code : B01005	Signal de câble assemblé, C114bl+NP2C/NC3FX 3m
P	RF219 Code : B01007	Signal de câble assemblé, C114bl+NP2C/NC3FX 9m

B	PRE-DPR-RF313black Code : B01051	MF114ZW03 - Signal de câble assemblé, C11
D	PRE-DPR-RF3110black Code : B01053	MF114ZW10 - Signal de câble assemblé, C1
F	PRE-DPR-RF333black Code : B01060	MF128ZW03 - Signal de câble assemblé, C12
H	PRE-DPR-RF3310black Code : B01062	MF128ZW10 - Signal de câble assemblé, C1
K	RF146 Code : B01001	Signal de câble assemblé, C114bl+NP2C/NP2C 6m
M	RF142 Code : B01003	Signal de câble assemblé, C114bl+NP2C/NP2C 12m
O	RF216 Code : B01006	Signal de câble assemblé, C114bl+NP2C/NC3FX 6m
R	RF212 Code : B01008	Signal de câble assemblé, C114bl+NP2C/NC3FX 12m

SPEAKER CABLES

tasker



A	PRE-DPR-SS T23ZW03 Code : B01065	Câble de haut-parleur assemblé, 2xAW13 + 2xNL2
C	PRE-DPR-SS T23ZW10 Code : B01067	Câble de haut-parleur assemblé, 2xAW13 + 2xNL2
E	PRE-DPR-SS T23ZW20 Code : B01069	Câble de haut-parleur assemblé, 2xAW13 + 2xNL2
G	PRE-DPR-SS T27ZW05 Code : B01071	Câble haut-parleur assemblé, 4xAWG13 + 2xNL
I	PRE-DPR-SS T27ZW15 Code : B01073	Câble haut-parleur assemblé, 4xAWG13 + 2xNL

B	PRE-DPR-SS T23ZW05 Code : B01066	Câble de haut-parleur assemblé, 2xAW13 + 2xNL2
D	PRE-DPR-SS T23ZW15 Code : B01068	Câble de haut-parleur assemblé, 2xAW13 + 2xNL2
F	PRE-DPR-SS T27ZW03 Code : B01070	Câble haut-parleur assemblé, 4xAWG13 + 2xNL
H	PRE-DPR-SS T27ZW10 Code : B01072	Câble haut-parleur assemblé, 4xAWG13 + 2xNL
J	PRE-DPR-SS T27ZW20 Code : B01074	Câble haut-parleur assemblé, 4xAWG13 + 2xNL



LINE AUDIO CABLES

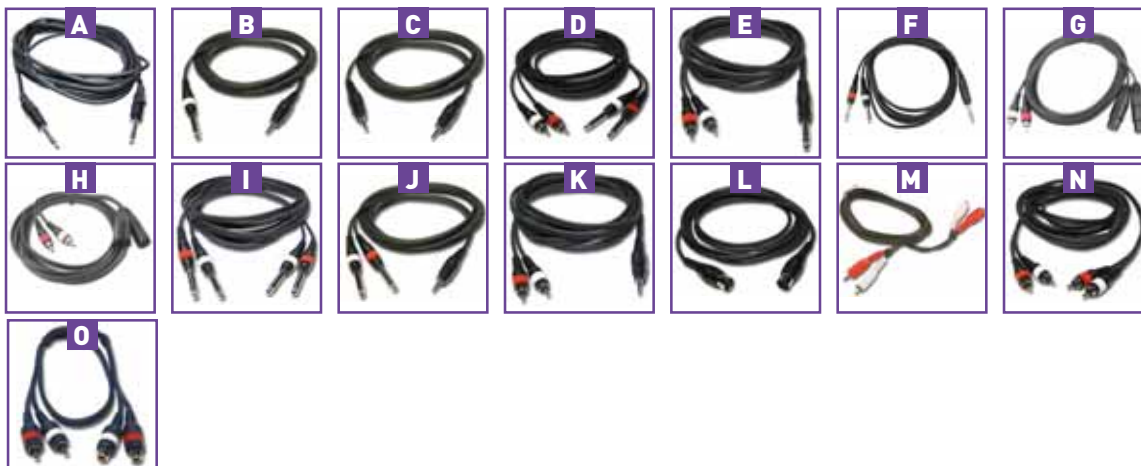

A	CL-07/1.5 Code : H7995	Stereo Male jack / stereo Male jack line cable - 1.50m	H	CL-26/1.5 Code : H8167	2x4mm 2xXLR Male / 2xRCA Male line cable - 1.5m
	CL-07/3 Code : H7996	Stereo Male jack / stereo Male jack line cable - 3m		CL-26/3 Code : H8168	2x4mm 2xXLR Male / 2xRCA Male line cable - 3m
	CL-07/6 Code : H7997	Stereo Male jack / stereo Male jack line cable - 6m	I	FL-22/1.5 Code : H8012	2x4mm 2x Male jack / 2x Mono male jack line cable - 1.5m
	CL-07/10 Code : H7998	Stereo Male jack / stereo Male jack line cable - 10m		FL-22/3 Code : H8013	2x4mm 2x Male jack / 2x Mono male jack line cable - 3m
B	CL-71/1.5 Code : H7999	Stereo Male 3.5 mm jack / stereo Male 6.35 jack line cable - 1.50m		FL-22/6 Code : H8014	2x4mm 2x Male jack / 2x Mono Male jack line cable - 6m
	CL-71/3 Code : H8000	Stereo Male 3.5 mm jack / stereo Male 6.35 jack line cable - 3m	J	CL-31/1.5 Code : H8015	2x4mm 1x stereo Male 3.5 jack / 2x Male jack line cable - 1.5m
	CL-71/6 Code : H8001	Stereo Male 3.5 mm jack / stereo Male 6.35 jack line cable - 6m		CL-31/3 Code : H8016	2x4mm 1x stereo Male 3.5 jack / 2x Male jack line cable - 3m
	CL-71/10 Code : H8002	Stereo Male 3.5 mm jack / stereo Male 6.35 jack line cable - 10m	K	CL-30/1.5 Code : H8017	2x4mm 1x stereo Male 3.5 jack / 2xRCA Male line cable 1.5m
C	CL-72/1.5 Code : H8003	Jack 3,5 mm stereo Male / Jack 3,5 stereo Male cord line - 1.50m		CL-30/3 Code : H8018	2x4mm 1x stereo Male 3.5 jack / 2xRCA Male line cable 3m
	CL-72/3 Code : H8004	Jack 3,5 mm Stereo Male / Jack 3,5 stereo Male cord line - 3m	L	CL-51/0.6 Code : H9299	DIN 5-pin male / DIN 5-pin male midi cable - 0.6m
	CL-72/6 Code : H8005	Jack 3,5 mm Stereo Male / Jack 3,5 stereo Male cord line - 6m		CL-51/1 Code : H9300	DIN 5-pin male / DIN 5-pin male midi cable - 1m
	CL-72/10 Code : H8006	Jack 3,5 mm stereo Male / Jack 3,5 stereo Male cord line - 10m		CL-51/3 Code : H8019	DIN 5-pin male / DIN 5-pin male midi cable - 3m
D	CL-23/1.5 Code : H8007	2x4mm 2x Male jack / 2xRCA Male line cable - 1.5m		CL-51/6 Code : H8020	DIN 5-pin male / DIN 5-pin male midi cable - 6m
	CL-23/3 Code : H8008	2x4mm 2x Male jack / 2xRCA Male line cable - 3m	M	RCA1/C Code : H0049	2 RCA male / 2 RCA male cable - 1.2 m
E	CL-35/1.5 Code : H8009	2x4mm 1 stereo Male jack / 2xRCA Male line cable - 1.5m	N	CL-24/1.5 Code : H7964	2x4mm 2xRCA Male / 2xRCA Male line cable - 1.5m
	CL-35/3 Code : H8010	2x4mm 1 stereo Male jack / 2xRCA Male line cable - 3m		CL-24/3 Code : H7965	2x4mm 2xRCA Male / 2xRCA Male line cable - 3m
	CL-35/6 Code : H8011	2x4mm 1 stereo Male jack / 2xRCA Male line cable - 6m		CL-24/6 Code : H7966	2x4mm 2xRCA Male / 2xRCA Male line cable - 6m
F	CL-36/1.5 Code : H9294	Stereo male 6.35 jack / 2 x mono 6.35 jack line cable - 1.5m	O	CL-27/1.5 Code : H7967	2xRCA Female / 2xRCA Male line cable - 1.5m
	CL-36/3 Code : H9295	Stereo male 6.35 jack / 2 x mono 6.35 jack line cable - 3m		CL-27/3 Code : H7968	2xRCA Female / 2xRCA Male line cable - 3m
G	CL-25/1.5 Code : H8165	2x4mm 2xXLR Female / 2xRCA Male line cable - 1.5m		CL-27/6 Code : H7969	2xRCA Female / 2xRCA Male line cable - 6m
	CL-25/3 Code : H8166	2x4mm 2xXLR Female / 2xRCA Male line cable - 3m			



A	RCA11/C Code : H7970	High quality cable - 2 RCA male / 2 RCA male - 1.20m	I	INSERT-JACKm-1M5 Code : B01240	Insert cable - stereo jack - 2x mono jack - 1.5m
	RCA13/C Code : H7971	High quality cable - 2 RCA male / 2 RCA male - 3m		INSERT-JACKm-3M Code : B01241	Insert cable - stereo jack - 2x mono jack - 3m
	RCA15/C Code : H7972	High quality cable - 2 RCA male / 2 RCA male - 5m	J	JACKm/JACKm-90D-0M ³ Code : B01242	Multicolour Jack ←→ Jack 90° - 0.3m (6pcs)
B	RCA/PH Code : H7973	2 RCA male / 2 RCA male cable + mass - 3m	K	JACKm/JACKm-TWIN-1M5 Code : B01243	2x mono jack - 2x mono jack cable - 1.5m
C	RCA25/C Code : H7974	4 RCA male / 4 RCA male cable - 1.50m		JACKm/JACKm-TWIN-3M Code : B01244	2x mono jack - 2x mono jack cable - 3m
D	2-0365 Code : B01220	Signal cable, 2xRCA + 2xRCA 0.5m	L	miniJACK/2xJACK-1M5 Code : B01245	Stereo 3.5 jack - 2x mono jack cable - 1.5m
	2-0368 Code : B01221	Signal cable, 2xRCA+2xRCA 1.0m		miniJACK/2xJACK-3M Code : B01246	Stereo 3.5 jack - 2x mono jack cable - 3m
	2-0370 Code : B01222	Signal cable, 2xRCA + 2xRCA 1.5m	M	MJC-1M5 Code : B01217	Signal cable, 2xRCA+ stereo 3.5 jack 1.5m
	2-0375 Code : B01223	Signal cable, 2xRCA + 2xRCA 2,5m	N	MJMJ-1M5 Code : B01236	Male 3.5 jack / male 3.5 jack cable - 1.5m
	2-0380 Code : B01224	Signal cable, 2xRCA+2xRCA 5,0m	O	MJMfJ-3M Code : B01237	3.5 jack/3.5 jack extension - 3m
E	2-0425 Code : B01210	Signal cable, mono jack + mono jack 6m	P	RCAm/RCAf-TWIN-3M Code : B01247	2x RCA male ←→ 2x RCA female cable - 3m
	2-0426 Code : B01211	Signal cable, mono jack + mono jack 10m	Q	SJXF-1M5 Code : B01218	Balanced signal cable, Stereo Jack / XLR Female 1.5m
F	2-0430 Code : B01215	Signal cable, 2xRCA+ mono jack 1.5m	R	SJXM-1M5 Code : B01219	Balanced signal cable, Stereo Jack/ XLR Male 1.5m
	2-0435 Code : B01216	Signal cable, 2xRCA+ mono jack 3m	S	SNAKE-8XLRmf-3M Code : B01248	Snake cable 8x XLRm ←→ XLRf - 3m
G	2-0440 Code : B01235	Signal cable, 2xRCA+XLRf 1.5m		SNAKE-8XLRmf-6M Code : B01249	Snake cable 8x XLRm ←→ XLRf - 6m
H	2-0445 Code : B01230	Signal cable, 2xRCA+XLRm 1.5m		SNAKE-8XLRmf-9M Code : B01250	Snake cable 8x XLRm ←→ XLRf - 9m



MICROPHONE CABLES



A	CM/XFXM-0,6 Code : H9298	XLR female / XLR male microphone cable - 0.6m	C	CM/XMJM-1,5 Code : H9296	XLR male / mono male 6.35 jack microphone cable - 1.5m
	CM/XFXM-1,5 Code : H7947	XLR female / XLR male microphone cable - 1.5m		CM/XMJM-3 Code : H9297	XLR male / mono male 6.35 jack microphone cable - 3m
	CM/XFXM-3 Code : H7948	XLR female / XLR male microphone cable - 3m		CM/XMJM-6 Code : H7957	XLR male / mono male 6.35 jack microphone cable - 6m
	CM/XFXM-6 Code : H7949	XLR female / XLR male microphone cable - 6m		CM/XMJM-10 Code : H7958	XLR male / mono male 6.35 jack microphone cable - 10m
	CM/XFXM-10 Code : H7950	XLR female / XLR male microphone cable - 10m	D	7-0060 Code : B01205	Signal cable, XLRf+mono jack 5m
	CM/XFXM-20 Code : H7951	XLR female / XLR male microphone cable - 20m		7-0066 Code : B01206	Signal cable, XLRf+mono jack 10m
A1	XMF-0.50M Code : B01207	Signal cable, XLRf+XLRm 0.5m	E	7-0061 Code : B01203	Signal cable, XLRf+XLRm 1m
B	CM/XFJM-1,5 Code : H7952	XLR female / male jack microphone cable - 1.5m		7-0062 Code : B01204	Signal cable, XLRf+XLRm 2,5m
	CM/XFJM-3 Code : H7953	XLR female / male jack microphone cable - 3m		7-0063 Code : B01200	Signal cable, XLRf+XLRm 5m
	CM/XFJM-6 Code : H7954	XLR female / male jack microphone cable - 6m		7-0067 Code : B01201	Signal cable, XLRf+XLRm 10m
	CM/XFJM-10 Code : H7955	XLR female / male jack microphone cable - 10m		7-0068 Code : B01202	Signal cable, XLRf+XLRm 20m
	CM/XFJM-20 Code : H7956	XLR female / male jack microphone cable - 20m			

SPEAKER CABLES



A	CH/JMJM-1.5 Code : H8023	Male jack / Male jack 2x1.5 HP cable - 1.5m	D	CSP215/0.5 Code : H10695	2 speaker cable x 1.5 mm ² speakon/speakon NEUTRIK - 0.5m
	CH/JMJM-3 Code : H8024	Male jack / Male jack 2x1.5 HP cable - 3m		CSP215/1 Code : H10696	2 speaker cable x 1.5 mm ² speakon/speakon NEUTRIK - 1m
	CH/JMJM-10 Code : H8025	Male jack / Male jack 2x1.5 HP cable - 10m		CSP215/3 Code : H9840	2 speaker cable x 1.5 mm ² speakon/speakon NEUTRIK - 3m
	CH/JMJM-15 Code : H8026	Male jack / Male jack 2x1.5 HP cable - 15m		CSP215/6 Code : H9841	2 speaker cable x 1.5 mm ² speakon/speakon NEUTRIK - 6m
B	CH/SMJM-3 Code : H8034	Speakon Male / Male jack 2x1.5 HP cable - 3m		CSP215/10 Code : H9842	2 speaker cable x 1.5 mm ² speakon/speakon NEUTRIK - 10m
	CH/SMJM-6 Code : H8035	Speakon Male / Male jack 2x1.5 HP cable - 6m	E	2-0505 Code : B01252	Speakon Male / speakon Male HP cable - 5m
	CH/SMJM-10 Code : H8036	Speakon Male / Male jack 2x1.5 HP cable - 10m		2-0510 Code : B01253	Speakon Male / speakon Male HP cable - 10m
	CH/SMJM-20 Code : H8037	Speakon Male / Male jack 2x1.5 HP cable - 20m		2-0525 Code : B01254	Speakon Male / speakon Male HP cable - 25m
C	CS-21/3 Code : H8038	Speakon Male / speakon Male 2x1.5 HP cable - 3m			
	CS-21/6 Code : H8039	Speakon Male / speakon Male 2x1.5 HP cable - 6m			
	CS-21/10 Code : H8040	Speakon Male / speakon Male 2x1.5 HP cable - 10m			
	CS-21/15 Code : H8041	Speakon Male / speakon Male 2x1.5 HP cable - 15m			
	CS-21/20 Code : H8042	Speakon Male / speakon Male 2x1.5 HP cable - 20m			

DMX CABLES



A	CDU0-10 Code : H9274	VDE / CEE - XLR male / XLR female hybrid audio cable - 10 metres	AUDIO COMBI CABLE IEC/XLR-5M Code : B01400	IEC / XLR Male / XLR Female hybrid audio cable - 5 metres	
	CDU0-20 Code : H9293	VDE / CEE - XLR male / XLR female Hybrid Sound Cord - 20 meters	C	AUDIO COMBI CABLE SCHUKO/XLR-10M Code : B01404	VDE / CEE - XLR male / XLR female Hybrid Sound Cord - 10 meters
B	AUDIO COMBI CABLE IEC/XLR-10M Code : B01401	IEC / XLR Male / XLR Female Hybrid Sound Cord - 10 Meters		AUDIO COMBI CABLE SCHUKO/XLR-20M Code : B01405	VDE / CEE - XLR male / XLR female Hybrid Sound Cord - 20 meters
	AUDIO COMBI CABLE IEC/XLR-20M Code : B01402	IEC / XLR Male / XLR Female Hybrid Sound Cord - 20 Meters		AUDIO COMBI CABLE SCHUKO/XLR-5M Code : B01403	VDE / CEE - XLR male / XLR female Hybrid Sound Cord - 5 meters

DMX CABLES



A	CDMX-0.6 Code : H10699	DMX XLR male / XLR female 3 pin cable - 0.6m	B	XLR5 M-M 0,5M Code : B01208	DMX conversion cable: 5-pin male to male XLR connectors
	CDMX-1 Code : H9273	Cable for DMX XLR Male / XLR female 3 pins Length: 1 m	C	IPCD-1 Code : H10722	DMX 3P waterproof connection cable for IPZOOM - 1m
	CDMX-1.5 Code : H9288	Cord for DMX XLR Male / XLR female 3 pins Length: 1.5 m		IPCD-2 Code : H10723	DMX 3P waterproof connection cable for IPZOOM - 2m
	CDMX-3 Code : H9289	Cord for DMX XLR Male / XLR female 3 pins Length: 3 m		IPCD-5 Code : H10724	DMX 3P waterproof connection cable for IPZOOM - 5m
	CDMX-5 Code : H9290	Cord for DMX XLR Male / XLR female 3 pins Length: 5 m			
	CDMX-10 Code : H9291	Cord for DMX XLR Male / XLR female 3 pins Length: 10 m	D	BT-XLR3T05 KIT Code : B05523	Kit de modification pour modifier IP XLR3pin à 5 broches
	CDMX-20 Code : H9292	Cord for DMX XLR Male / XLR female 3 pins Length: 20 m	E	PRE-DPR-RF3301.5BLACK Code : B01424	MF128ZW1,5 - Câble DMX 1,5m avec neutre
F	PRE-5M5F1038ZW1,5 (BAG) Code : B01407	Câble DMX 1,5m avec Neutrik XLR 5p black	G	PRE-5M5F1038ZW03 (BAG) Code : B01408	Câble DMX 3m avec Neutrik XLR 5p black
H	PRE-5M5F1038ZW05 (BAG) Code : B01409	Câble DMX 5m avec Neutrik XLR 5p black	I	PRE-5M5F1038ZW10 (BAG) Code : B01410	Câble DMX 10m avec Neutrik XLR 5p black
J	PRE-5M5F1038ZW20 (BAG) Code : B01411	Câble DMX 20m avec Neutrik XLR 5p black			



DMX COMBI CABLES



A	CPCDMXLINK-1 Code : H10686	POWERCON / XLR hybrid cable 3G1.5mm ² - 1m
	CPCDMXLINK-3 Code : H10687	POWERCON / XLR hybrid cable 3G1.5mm ² - 3m
	CPCDMXLINK-5 Code : H10688	POWERCON / XLR hybrid cable 3G1.5mm ² - 5m
B	CPCDMXIN-3 Code : H10689	POWERCON-PC16A / XLR hybrid cable 3G1.5mm ² - 3m
	CPCDMXIN-5 Code : H10690	POWERCON-PC16A / XLR hybrid cable 3G1.5mm ² - 5m
	CPCDMXIN-10 Code : H10691	POWERCON-PC16A / XLR hybrid cable 3G1.5mm ² - 10m
C	COMBI CABLE IEC/ XLR 1.3m Code : B01255	Power(IEC)+DMX cable 1.3m
	COMBI CABLE IEC/XLR 3M Code : B01256	Power(IEC)+DMX cable 3.0m
	COMBI CABLE IEC/XLR 5M Code : B01257	Power(IEC)+DMX cable 5,0m
	COMBI CABLE IEC/XLR 10M Code : B01258	Power(IEC)+DMX cable 10,0m

D	POWERCON/XLR COMBI 3x1.5mm ² CABLE 1M3 Code : B01263	1.3 m POWERCON Neutrik / XLR hybrid cable 3G1.5mm ²
	POWERCON/XLR COMBI 3x1.5mm ² CABLE 3M Code : B01264	3m POWERCON Neutrik / XLR hybrid cable 3G1.5mm ²
	POWERCON/XLR COMBI 3x1.5mm ² CABLE 5M Code : B01265	5m POWERCON Neutrik / XLR hybrid cable 3G1.5mm ²
	POWERCON/XLR COMBI 3x1.5mm ² CABLE 10M Code : B01266	10m POWERCON Neutrik / XLR hybrid cable 3G1.5mm ²

* Combination of a power cable 3 x 1.5 mm² (16 A max.) and a symmetrical shielded signal cable. Equipped with XLR male / female connectors and IP power.

POWER CABLES



A	IECMF-1 Code : H9889	IEC male / female 1m cables	
	IECMF-3 Code : H9890	IEC male / female 3m cables	
	IECMF-5 Code : H9891	IEC male / female 5m cables	
	IECMF-7 Code : H9892	IEC male / female 7m cables	
B	CPCIN-1 Code : H10684	NAC3FCA / 3G1.5mm cable ² / PC16A - 1m	
	CPCIN-2.5 Code : H10685	NAC3FCA / 3G1.5mm cable ² / PC16A - 2.5m	
C	CPCLINK-0.5 Code : H10692	NAC3FCA / NAC3FCB 3G0.75mm cable ² ET 3G2mm ² - 0.5m	
	CPCLINK-1 Code : H10693	NAC3FCA / NAC3FCB 3G0.75mm cable ² ET 3G2mm ² - 1m	
	CPCLINK-1.5 Code : H10694	NAC3FCA / NAC3FCB 3G0.75mm cable ² ET 3G2mm ² - 1.5m	
D	IPCP-1 Code : H10725	Waterproof electrical connection cable for IPZOOM -1m	
	IPCP-2 Code : H10726	Waterproof electrical connection cable for IPZOOM -2m	
	IPCP-5 Code : H10727	Waterproof electrical connection cable for IPZOOM -5m	
E	ALIM315/3 Code : H9848	Extension cable with rubber plugs H07RN- F3G1.5 - 3m	
	ALIM315/5 Code : H9849	Extension cable with rubber plugs H07RN- F3G1.5 - 5m	
	ALIM315/10 Code : H9850	Extension cable with rubber plugs H07RN- F3G1.5 - 10m	
F	ALIM325/3 Code : H9851	Extension cable with rubber plugs H07RN- F3G2.5 - 3m	
	ALIM325/5 Code : H9852	Extension cable with rubber plugs H07RN- F3G2.5 - 5m	
	ALIM325/10 Code : H9853	Extension cable with rubber plugs H07RN- F3G2.5 - 10m	
G	MULT6E Code : H10841	European extension socket 6 outlets	
H	MULT4E Code : H10842	Power outlets 4 European outlets	
I	MULTIP6F Code : H10843	French extension socket 6 outlets - IP44	
J	MULTIP6E Code : H10844	European extension socket 6 outlets - IP44	
K	MULTIP4F Code : H10845	Power outlets 4 French sockets - IP44	
L	MULTIP4E Code : H10846	Power outlets 4 European outlets - IP44	
M	IECEUR3 Code : H10869	IEC female / Europe male cable - 3m / 3G1mm ²	
	IECEUR5 Code : H10870	IEC female / Europe male cable - 5m / 3G1mm ²	
N	CPCIN3 Code : H10871	Europe male / SEETRONIC cable - 3m / 3G1.5mm ²	
	CPCIN5 Code : H10872	Europe male / SEETRONIC cable - 5m / 3G1.5mm ²	
O	CEE-CABLE-32A-5G6-10M* Code : B01392		
	CEE-CABLE-32A-5G6-20M* Code : B01393		
	CEE-CABLE-32A-5G6-5M* Code : B01391		
P	CEE-CABLE-63A-5G16-10M* Code : B01395		
	CEE-CABLE-63A-5G16-20M* Code : B01396		
	CEE-CABLE-63A-5G16-5M* Code : B01394		
Q	IEC Cable M/F 1M Code : B04151	IEC male and female cables	
	IEC Cable M/F 5M Code : B04152	IEC male and female cable	
R	MULTISOCKET4-F** Code : B01352		
S	MULTISOCKET4-G** Code : B01353		
T	MULTISOCKET4PRO-F-3M** Code : B01387		
	MULTISOCKET4PRO-F-5M** Code : B01389		
U	MULTISOCKET4PRO-G-3M** Code : B01388		
	MULTISOCKET4PRO-G-5M** Code : B01390		
V	POWER CABLE CEE7/7-IEC 2M Code : B01350	CEE7/7-IEC power cable 2M	
W	POWER CABLE CEE7/7-PowerCON 2M Code : B01351	Power cable CEE7/7 - PowerCON	
X	POWERCABLE-3G1,5-10M-F Code : B01377	Extension cable 3G1.5, 10m and French Schuko plug	
Y	POWERCABLE-3G1,5-10M-G Code : B01380	Extension cable 3G1.5, 10m and German Schuko plug	
Z	POWERCABLE-3G1,5-3M-F Code : B01375	Extension cable 3G1.5, 3m and French Schuko plug	
A1	POWERCABLE-3G1,5-3M-G Code : B01378	Extension cable 3G1.5, 3m and German Schuko plug	
B1	POWERCABLE-3G1,5-5M-F Code : B01376	Extension cable 3G1.5, 5m and French Schuko plug	
C1	POWERCABLE-3G1,5-5M-G Code : B01379	Extension cable 3G1.5, 5m and German Schuko plug	
D1	POWERCABLE-3G2,5-10M-F Code : B01382	Extension cable 3G2.5, 10m and French Schuko plug	
E1	POWERCABLE-3G2,5-10M-G Code : B01385	Extension cable 3G2.5, 10m and German Schuko plug	
F1	POWERCABLE-3G2,5-20M-F Code : B01383	Extension cable 3G2.5, 20m and French Schuko plug	
G1	POWERCABLE-3G2,5-20M-G Code : B01386	Extension cable 3G2.5, 20m and German Schuko plug	
H1	POWERCABLE-3G2,5-5M-F Code : B01381	Extension cable 3G2.5, 5m and French Schuko plug	
I1	POWERCABLE-3G2,5-5M-G Code : B01384	Extension cable 3G2.5, 5m and German Schuko plug	
J1	POWERCABLE-3G2,5-3M-F Code : B01397	Extension cable 3G2.5, 3m and French Schuko plug	
K1	POWERCABLE-3G2,5-3M-G Code : B01398	Extension cable 3G2.5, 3m and German Schuko plug	
L1	CABLE CASE Code : B03244	Extra solid flight case specially designed to carry cables and other heavy objects.	
M2	POWERCABLE TRUE1 2M Code : B01440	Câble d'alimentation 3x1,5mm ² avec Powercon TRUE	
N2	TRUE1/XLR-3P COMBI CABLE 1,5M Code : B01425	DMX + POWER 3x1,5mm ² câble T	
O2	TRUE1/XLR-5P COMBI CABLE 1,5M Code : B01412	DMX + POWER 3x1,5mm ² câble T	
P2	TRUE1/XLR-3P COMBI CABLE 3M Code : B01426	DMX + POWER 3x1,5mm ² câble TRU	
Q2	TRUE1/XLR-5P COMBI CABLE 3M Code : B01413	DMX + POWER 3x1,5mm ² câble TRU	
R2	TRUE1/XLR-3P COMBI CABLE 5M Code : B01427	DMX + POWER 3x1,5mm ² câble TRU	
S2	TRUE1/XLR-5P COMBI CABLE 5M Code : B01414	DMX + POWER 3x1,5mm ² câble TRU	

*5-pole CEE extension cable with transparent heat-shrinkable sheath for custom labels.

**4-outlet power distribution box with sliding mounting bracket and transparent heat-shrinkable sheath for custom labels.



USB CABLES



A	CU/AMAF Code : H9271	USB2.0 A male / A female cable - 5m
B	CU/AMBM-1 Code : H9272	USB2.0 A male / USB2.0 B male cable - 1m
	CU/AMBM-5 Code : H9287	USB2.0 A male / USB2.0 B male cable - 5m
C	USB2 A-B 2M Code : B01273	USB2 A-B 2M
	USB2 A-B 3M Code : B01274	USB2 A-B 3M

D	USB3 A-B 2M Code : B01275	USB3 A-B 2M
	USB3 A-B 3M Code : B01276	USB3 A-B 3M

INSTALLATION CABLE AUDIO

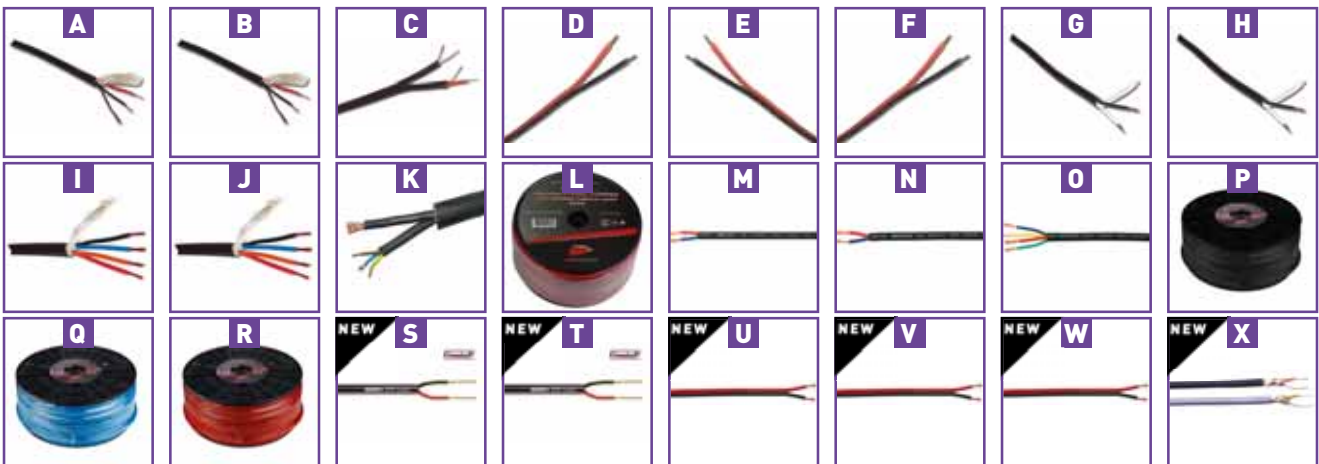

A	PROMI/20 Code : H8099	6 mm black microphone cable - 100m coil
B	PROMI/30 Code : H8100	6 mm black high quality microphone cable 100 m
C	MEP/ASY Code : H8103	Flat cable 2 x 4 mm ² asymmetrical black- 100 m coil
D	MEP-2075 Code : H8104	HP flat cable 2 x 0.75mm ² red and black - 100 m coil
E	MEP-2150 Code : H8105	HP Flat Cable 2 x 1.5 mm ² rouge et noir - bobine de 100 m
F	MEP-2200 Code : H8106	HP Flat Cable 2 x 2mm ² rouge et noir - bobine de 100 m
G	PROHP-215 Code : H8107	HP 2 x 1.5 mm cable ² black - coil 100 m
H	PROHP-225 Code : H8108	HP 2 x 2.5 mm cable ² black - coil 100 m
I	PROHP-425 Code : H8109	HP 4 x 2.5 mm cable ² black - coil 50 m
S	TAS-C275lszh Code : B01428	Low smoke/zero halogen Loudspeaker Cable 2*1
U	C102 (2x0.75 r/z) Code : B00933	Speaker cable, flat: 2x0.75mm ² , red/black
W	C102 (2x2.50 r/z) Code : B00935	Speaker cable, flat: 2x2.50mm ² , red/black

J	PROHP-440 Code : H8110	HP 4 x 4 mm cable ² black - 50 m coil
K	DUOSOUND Code : H9855	Hybrid power cable 3 x 1.5 mm ² + AUDIO - 50m
L	SPR2150 Code : B01290	Round cable of very good quality 2x1.50mm ² (100m coil)
M	SPR2250 Code : B01291	Round cable of very good quality 2x2.50mm ² (100m coil)
N	SPR2400 Code : B01292	Round cable of very good quality 2x4.00mm ² (50m coil)
O	SPR4250 Code : B01293	Round cable of very good quality: 4x2.50mm ² (50m coil)
P	MC-01 Black Code : B01280	Symmetrical microphone cable of very good quality
Q	MC-01 Blue Code : B01281	Symmetrical microphone cable of very good quality
R	MC-01 Red Code : B01282	Symmetrical microphone cable of very good quality
T	TAS-C276lszh Code : B01429	Low smoke/zero halogen Loudspeaker Cable 2*2
V	C102 (2x1.50 r/z) Code : B00934	Speaker cable, flat: 2x1.50mm ² , red/black
X	C114 Black Code : B00950	Bal. mic/audio cable, round: 2x0.25mm ² , black

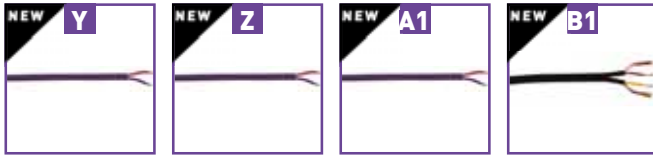

Y	C128 Black Code : B00956	Bal. mic/audio cable, round: 2x0,35mm ² , black	Z	C276 [2x2,5] Code : B00960	Speaker cable, round: 2x2.50mm ² , black, reel
A1	C275 [2x1,5] Code : B00961	Speaker cable, round: 2x1.50mm ² , black, reel	B1	C118 Black Code : B00963	Stereo audio cable, round: 2x0,14mm ² , black, 10

VIDEO CABLES



A	HDMI 1M Code : B01270	High speed HDMI cable
	HDMI 2M Code : B01271	High speed HDMI cable

LIGHT CABLE



A	DUOLIGHT Code : H9854	Hybrid power cable 3 x 2.5 mm ² + DMX - 50m
B	DMX-DOUB Code : H8101	DMX digital cable 2 conductors black - price per metre
C	DMX-QUAD Code : H8102	DMX digital cable 4 conductors black - price per meter

ELECTRICAL CABLE



A	TIT-315 Code : H6755	Titanex cable LENS H07RNF 3 x 1.5 mm ² 100m coil
B	TIT-325 Code : H6756	Titanex cable LENS H07RNF 3 x 2.5 mm ² 100m coil







NEUTRIK® connectors

	NE8MC Code : H10446	Cat5e RJ45 cable plug body
	NE8FDP Code : H10447	Female socket for CAT5e RJ45 cable
	NC-3-FXX Code : B01102	Neutrik XLR female connector for cable, 3-pin.
	NC-3-FXX Code : H8846	3-pin NEUTRIK female XLR plug
	NC-3-MXX Code : B01101	Neutrik XLR male connector for cable, 3-pin.
	NC-3-MXX Code : H8848	3-pin NEUTRIK male XLR plug
	NC-3-FX-HD Code : H10714	NEUTRIK 3-pole XLR female IP67 water-proof plug
	NC-3-FX-HD Code : H10715	NEUTRIK 3-pole XLR male IP67 water-proof plug
	NC-5-FXX Code : B01117	Neutrik XLR female connector for cable, 5-pin
	NC-5-FXX Code : H8850	5-pin NEUTRIK female XLR plug
	NC-5-MXX Code : B01118	Neutrik XLR male connector for cable, 5-pin
	NC-5-MXX Code : H8851	5-pin male XLR plug NEUTRIK
	NC-3-FD-L-1 Code : B01127	Female XLR chassis, lockable, D-size, 3-pin from Neutrik.
	NC-3-FDLX Code : H8852	NEUTRIK X series 3-pin female XLR socket
	NC-3-MD-L-1 Code : B01128	Male XLR chassis, lockable, [D-size], 3 pins from Neutrik.
	NC-3-MDLX Code : H8853	NEUTRIK X series 3-pin male XLR socket
	NC-5-FDLX Code : B01123	Neutrik D-size 5pin XLR-f CHASSIS
	NC-5-FDL1 Code : H4840	NEUTRIK D series 5-pin female XLR socket
	NC-5-MDLX Code : B01124	Neutrik D-size 5pin XLR-m CHASSIS
	NC-5-MDL1 Code : H4841	NEUTRIK D series 5-pin male XLR socket
	NA-USB Code : H8854	NEUTRIK D Series USB-A-B socket
	NYS373-0 Code : H8855	NEUTRIK gold contact RCA plug - Black
	NYS373-2 Code : H8856	NEUTRIK gold contact RCA plug - Red
	NTP3RC Code : H7946	NEUTRIK angled stereo 3.5 JACK plug
	NP-2-X Code : B01104	Neutrik 6.3mm JACK-m mono CABLE.
	NP-2X Code : H8859	NEUTRIK male mono 6.35 JACK plug
	NP-3-X Code : B01103	Neutrik 6.3mm JACK-m stereo CABLE
	NP-3X Code : H8861	NEUTRIK male stereo 6.35 JACK plug
	NJ-3-FC-6 Code : B01106	Neutrik 6.3mm JACK-f stereo CABLE
	NJ-3FC6 Code : H4846	NEUTRIK female stereo 6.35 jack plug
	NJ-3-FP-6C Code : B01105	Neutrik D-size stereo 6.3mm JACK-f CHASSIS
	NJ-3FP6C Code : H4848	NEUTRIK D series female stereo 6.35 JACK socket

	NP2C-SILENT Code : H8857	NEUTRIK anti-plock mono jack plug
	NP2RX-SILENT Code : H8858	NEUTRIK anti-plock angled mono jack plug
	NC-3FRX Code : H8863	3-pin NEUTRIK angled female XLR plug
	NC-3MRX Code : H8865	3-pin NEUTRIK angled male XLR plug
	NP-2RX Code : H4854	NEUTRIK angled male mono 6.35 JACK plug
	NP-3RX Code : H4855	NEUTRIK angled male stereo 6.35 JACK plug
	NL-2-FX Code : B01136	Neutrik Speakon CABLE, 2 contacts.
	NL-2FX Code : H4856	NEUTRIK SPEAKON plug, 2 contacts
	NL-4-FX Code : B01113	Neutrik Speakon CABLE, 4 contacts.
	NL-4FX Code : H4857	NEUTRIK X series SPEAKON plug, 4 contacts
	NL-4-MMX Code : B01116	Neutrik 2x Speakon ADAPTER, 4 contacts.
	NL-4MMX Code : H4859	NEUTRIK X series SPEAKON coupler, 4 contacts
	NL-2MP Code : H4861	NEUTRIK D series SPEAKON socket, 2 contacts
	NL-4-MP Code : B01115	Neutrik Speakon CHASSIS, D-size, 4 contacts.
	NL-4MP Code : H4862	NEUTRIK 4-way SPEAKON 2-way socket
	NL-4-MP-R Code : B01114	Neutrik Speakon BIG CHASSIS, 4 contacts.
	NL-4MPR Code : H4863	NEUTRIK SPEAKON socket, 4 contacts, EP format
	NAC3FX-W Code : B01132	PowerCON TRUE1 locking female cable connector with power-in and screw terminals.
	NAC3FX-W Code : H10448	Powercon True one female plug
	NAC3MX-W Code : B01131	PowerCON TRUE1 locking male cable connector with power-out and screw terminals.
	NAC3MX-W Code : H10449	Powercon True one male plug
	NAC3MPX Code : B01134	NEUTRIK PowerCON TRUE1 appliance inlet connector with 1/4" flat tab terminals.
	NAC3MPX Code : H10450	Powercon True one male socket
	NAC3FPX Code : B01135	NEUTRIK PowerCON TRUE1 appliance outlet connector with 1/4" flat tab terminals.
	NAC3FPX Code : H10451	Powercon True one female socket
	NAC3PX Code : B01133	PowerCON TRUE1 appliance inlet-outlet combination with 1/4" flat tab terminals.
	NAC-3-FCA Code : B01125	Neutrik PowerCon inlet (blue) CABLE
	NAC-3FCA Code : H4865	NEUTRIK 240V 20A male power input plug, 3 contacts
	NAC-3-FCB Code : B01129	Neutrik PowerCon outlet (grey) CABLE
	NAC-3FCB Code : H4866	NEUTRIK 240V 20A male power output plug, 3 contacts
	NAC-3-MPA Code : B01126	Neutrik D-size PowerCon inlet (blue) CHASSIS
	NAC-3MPA Code : H4867	NEUTRIK 240V 20A power input socket, 3 contacts
	NAC-3-MPB Code : B01130	Neutrik D-size PowerCon outlet (grey) CHASSIS
	NAC-3MPB Code : H4868	NEUTRIK 240V 20A power output socket, 3 contacts

	NF2D0 Code : H10452	RCA socket, black, D format
	NF2D2 Code : H10453	RCA socket, red, D format
	NA-3F5M Code : H4869	NEUTRIK DMX XLR 3 fem. / XLR 5 male adapter
	NA-3M5F Code : H4870	NEUTRIK DMX XLR 3 male / XLR 5 female adapter
	DBA Code : B01119	cover for Neutrik D chassis

	NC3FDLXBAG Code : B01141	X series 3-pin female XLR socket / black - NEUTRIK
	NC3MDLXBAG Code : B01140	X series 3-pin male XLR socket / black - NEUTRIK
	NC3FXXBAG Code : B01143	3-pin female XLR plug / black - NEUTRIK
	NC3MXXBAG Code : B01142	3-pin female XLR plug / black - NEUTRIK

ELECTRICAL CONNECTORS

	CEE100 Code : H0227	CEE 22 chassis - male
	CEE300 Code : H0225	CEE 22 plug - male
	FIC/MAL Code : H1804	Male plastic plug 2 poles + earth
	FIC/CAH/MAL Code : H1806	Male rubber plug 2 poles + earth
	FIC/SCHU/MAL Code : H8131	Male rubber plug IP44 schuko

	CEE200 Code : H1659	CEE 22 chassis female
	CEE400 Code : H0226	CEE 22 plug - female
	FIC/FEM Code : H1805	Female plastic plug 2 poles + earth
	FIC/CAH/FEM Code : H1807	Female plug 2 poles + earth
	FIC/SCHU/FEM Code : H8132	Female rubber plug IP44 standard French

	SAC3FX Code : H10720	Waterproof Power In plug IP65 SEETRONIC
---	--------------------------------	---

	SAC3MX Code : H10721	Waterproof Power Out plug IP65 SEETRONIC
---	--------------------------------	--

* IP-POWER (input)/POWERCON (output) conversion adapter from IP class to normal Powercon connector.

** POWERCON (input) / IP-POWER (output) conversion adapter from normal Powercon connector to IP class connector.

	BT-16FS-F Code : B01406	Blue plug with IP44 cover, 230V/16A FRA/BEL
---	-----------------------------------	---













































CONNECTORS

	J35ST Code : H10876	Chrome stereo 3.5 jack plug
	J35STVIS Code : H10828	Chrome stereo 3.5 jack plug with screws
	FXF/CH Code : H2487	AUDIOPHONY XLR female plug - chrome finish
	FXF/NO Code : H7932	AUDIOPHONY X female plug - Black
	FXM/CH Code : H2488	AUDIOPHONY XLR male plug - chrome finish
	FXM/NO Code : H7933	AUDIOPHONY X male plug - Black
	XFC-103 Code : H6586	AUDIOPHONY D Series XLR female chassis
	XMC-103 Code : H6585	AUDIOPHONY D series XLR male chassis
	XMK-105 Code : H6587	5-pin male XLR plug for the AUDIOPHONY DMX
	XFK-105 Code : H6588	5-pin female XLR plug for the AUDIOPHONY DMX
	FJM/CH Code : H2495	AUDIOPHONY mono 6.35mm jack plug - chrome finish
	FJS/CH Code : H2496	AUDIOPHONY stereo 6.35mm jack plug - chrome finish
	J350/MO Code : H7936	AUDIOPHONY mono 6.35mm Jack female plug pro
	J350/STE Code : H7937	AUDIOPHONY professional stereo jack female plug - 6.35mm
	J700 Code : H7939	Stereo 6.35 mm jack female chassis with AUDIOPHONY lock
	RCA910/RO Code : H7940	Red male RCA plug for AUDIOPHONY professional cable
	RCA910/NO Code : H7941	Black male RCA plug for AUDIOPHONY professional cable
	RCA920/RO Code : H7942	Red female RCA plug for AUDIOPHONY professional cable
	RCA920/NO Code : H7943	Black female RCA plug for AUDIOPHONY professional cable

	BANA100/NO Code : H1653	AUDIOPHONY male banana plug - Black
	BANA100/RO Code : H1652	AUDIOPHONY male banana plug - Red
	BANA200/NO Code : H1655	AUDIOPHONY female banana chassis - Black
	BANA200/RO Code : H1654	AUDIOPHONY female banana chassis - Red
	BANA150/NO Code : H6595	AUDIOPHONY connector for amplifier terminal block, black
	BANA150/RO Code : H6596	AUDIOPHONY connector for amplifier terminal block, red
	BANA400/NO Code : H7944	AUDIOPHONY 2 x female banana chassis - 1 Red / 1 Black
	XLR female CHASSIS D-SIZE Code : B01306	XLR female chassis
	XLR male CHASSIS D-SIZE Code : B01305	XLR male chassis
	SC3FXX-W Code : H10716	XLR 3P female waterproof plug IP65 SEETRONIC
	SC3MXX-W Code : H10717	XLR 3P waterproof male plug IP65 SEETRONIC
	SC5FXX-W Code : H10718	XLR 5P female waterproof plug IP65 SEETRONIC
	SC5MXX-W Code : H10719	XLR 5P waterproof male plug IP65 SEETRONIC
	PROLOCK female CABLE Code : B01308	Female Pro Lock Connector
	PROLOCK male CABLE Code : B01307	Pro Lock Male Connector
	RCA female CABLE Code : B01311	RCA Female Connector
	RCA male CABLE Code : B01310	RCA Male Connector
	STEREOJACK 6.3mm FEMALE CABLE Code : B01302	stereo female 6.3mm jack
	STEREOJACK 6.3mm MALE CABLE Code : B01301	Stereo male 6.3mm jack
	XLR female CABLE Code : B01304	XLR female Connector
	XLR male CABLE Code : B01303	XLR male Connector

ADAPTERS

	ADAPT400 Code : H0505	AUDIOPHONY RCA female / mono male 6.35 jack adapter		ADAPT500 Code : H0766	AUDIOPHONY female 6.35 jack / RCA male adapter
	ADAPT600 Code : H1656	AUDIOPHONY 2 RCA female / 1 RCA male adapter		ADAPT700 Code : H1657	AUDIOPHONY RCA female / RCA female adapter
	ADAPT750 Code : H7927	AUDIOPHONY 2 x RCA female / 2 RCA female adapter		ADAPT800 Code : H0767	AUDIOPHONY female 6.35 jack / female 6.35 jack adapter
	ADAPT850 Code : H0506	AUDIOPHONY 2 female 6.35 jack / 1 male 6.35 jack adapter		ADAPT900 Code : H1658	AUDIOPHONY 2 RCA female / 1 stereo male 6.35 jack adapter
	ADAPT1000 Code : H7928	AUDIOPHONY stereo female 3.5 jack / stereo male 6.35 kack adapter		ADAPT1005 Code : H7929	AUDIOPHONY stereo female 6.35 jack / stereo male 3.5 jack adapter
	ADAPT1105 Code : H7931	AUDIOPHONY stereo RCA female / stereo male 3.5 jack adapter		ADAPT1200 Code : H9278	AUDIOPHONY stereo male 6.35 jack to 2 x 3 jack adapter
	ADA/XMXM Code : H2500	AUDIOPHONY XLR male / XLR male adapter		ADA/XFXF Code : H2501	AUDIOPHONY XLR female / XLR female adapter
	ADA/XFJF Code : H2502	AUDIOPHONY XLR female / female jack adapter		ADA/XMJF Code : H2503	AUDIOPHONY XLR male / female jack adapter
	ADA/XFRM Code : H2504	AUDIOPHONY XLR female / RCA male adapter		ADA/XMRM Code : H2505	AUDIOPHONY XLR male / RCA male adapter
	ADA/XFRF Code : H2506	AUDIOPHONY XLR female / RCA female adapter		ADA/XMRF Code : H2507	AUDIOPHONY XLR male / RCA female adapter
	ADA/XFJM Code : H6560	AUDIOPHONY XLR female / mono male jack adapter		ADA/XFJMS Code : H6561	AUDIOPHONY XLR female / stereo male jack adapter
	ADA/XMJM Code : H6562	AUDIOPHONY XLR male / mono male jack adapter		ADA/XMJMS Code : H6563	AUDIOPHONY XLR male / stereo male jack adapter
	ADA/XF5XM³ Code : H7925	AUDIOPHONY DMX XLR female 5 pins / XLR male 3 pins adapter		ADA/XM5XF3 Code : H7926	AUDIOPHONY DMX XLR male 5 pins / XLR female 3 pins adapter
	AS/SF-SF Code : H6583	AUDIOPHONY speaker extension adapter, 2 contacts		Adapter JACKf/JACKf Code : B01319	2x female jack adapter (stereo) with lock
	RCA female/MONOJACK adapter Code : B01312			RCA/RCA adapter Code : B01309	Double RCA female / female adapter
	RCAf/XLRf adapter Code : B01320			RCAf/XLRm adapter Code : B01321	Adapter RCAf/XLRm
	XLR female/ST.JACK adapter Code : B01314			XLR female/ST.JACK female adapter Code : B01316	
	XLR female/XLR female adapter Code : B01317			XLR male/ST.JACK adapter Code : B01313	XLR male / stereo male jack adapter
	XLR male/ST.JACK female adapter Code : B01315			XLR male/XLR male adapter Code : B01318	
	XLRmale 3P / XLRfem 5P adapter Code : B01277			XLRmale 5P / XLRfem 3P adapter Code : B01278	
	MONOJACK 6.3mm MALE CABLE Code : B01300			HEADPHONE ADAPTER Code : B01322	Universal headphone adapter





BT-XLR5T03 KIT Modification kit to modify IP
Code : B05517 XLR5pin to 3p



PRE-3M5F1038ZW0.15 [BAG] Adaptercable XLR 3p
Code : B01422 M - XLR 5p F









































PRE-5M3F1038ZW0.15 [BAG] Adaptercable XLR
Code : B01423 3p F - XLR 5p M

CONSTRUCTION

	COIN2PGM Code : H0735	2-legged metal corner - large model
	COIN3P Code : H0422	3-legged metal corner - medium model
	POIGNSURF Code : H0279	Recessed spring surface handle
	POIGNMARCH/PM Code : H4650	Metal Marshal handle - 220 x 160 x 60 mm
	ROUE100 Code : H0288	Swivel caster diameter 100 mm
	GRENOUILLE Code : H0698	Draw bolt
	PAPILLONGM Code : H0268	Large butterfly latch
	ECROUCAGE Code : H0270	Cage nut for PROFILRACK
	VISRACK/16 Code : H0271	Cage nut screw diameter 6 mm length 16 mm
	RENFORT Code : H0290	Metal corner reinforcement
	VCA512 Code : H8882	5x12 fluted rivet (box of 100)
	V561 Code : H8880	Black flat plastic washer - 5.5 x 10mm (per 100pcs)
	CORN3020 Code : H0827	Aluminium angle 30 x 20 mm - 2 m bar
	HYBRIDE10 Code : H0284	Aluminium hybrid profile - 2 m bar
	TOLE1U-NO Code : H0736	19" panel height 1 unit
	TOLE3U-NO Code : H0738	19" panel metal height 3 units

	COIN3PPM Code : H0274	3-legged metal corner - small model
	COIN3PGM Code : H0734	3-legged metal corner - large model
	POIGNRENOI Code : H0280	Recessed spring return handle
	POIGNMARCH/GM Code : H4652	Marshal handle, large model - 280 x 160 x 60 mm
	ROUE100FREIN Code : H0266	Swivel caster diameter 100 mm - with brake
	PAPILLONPM Code : H0287	Medium butterfly latch
	CHARNDEG Code : H0289	Detachable metal hinge, large model
	VISRACK/12 Code : H3085	Rack screw diameter 6 mm length 12 mm
	TAMPON Code : H0273	Rubber foot, large model
	VCA412 Code : H8881	4x12 fluted rivet (box of 100)
	VCA516 Code : H8883	5x16 fluted rivet (box of 100)
	CORN2020 Code : H0283	Aluminium angle 20 x 20 mm - 2 m bar
	CORN3030 Code : H0282	Aluminium angle 30 x 30 mm - 2 m bar
	PROFILRACK Code : H0281	Sliding rack profile - 2 m bar
	TOLE2U-NO Code : H0737	19" panel height 2 units
	TOLE4U-NO Code : H0739	19" panel metal height 4 units

CONSTRUCTION

	TOL12XLR Code : H0423	19" panel 1 unit for 6 XLR male chassis and 6 XLR female chassis
	TOLE2UV-NO Code : H0367	19" panel, height 2 units, vented - special aeration
	JB1200 Code : B00930	JB SYSTEMS Large recessed handle for speaker
	JB6 Code : B00921	JB SYSTEMS Small recessed handle for speaker
	JB8 Code : B00932	JB SYSTEMS Plastic protection corner for speaker
	SPEAKER GRILL 10inch Code : B00910	Strong black metal grill
	SPEAKER GRILL 15inch Code : B00912	Strong black metal grid
	SPEAKER GRILL 8inch Code : B00909	Strong black metal grid
	TE20 Code : B00918	Connection plate with 2x Speakon compatible connector ^{AB} and 2 screw connectors
	MS-00 Code : B03189	JV CASE 4x M6x16 + 4x plastic washers + 4x cage nut 2.2mm
	MS-02 Code : B03163	JV CASE 4x M6x16 + 4x plastic washers + 4x cage nut 1.5mm
	MS-04 Code : B03165	JV CASE 12x screw rack M6x16 + 12x plastic washers
	MS-07 Code : B03190	JV CASE Set 50x M3 screws/nuts for mounting Conn. of size D.
	RACK DRAWER 2U Code : B03194	JV CASE 19" 2U drawer for rack
	RACK TRAY 1U Code : B03197	JV CASE 19" 1U shelf
	RP 0.5U - 1/2U Rack panel Code : B03142	JV CASE 19" panel.
	RP 1U/V - 1U ventilation rack panel Code : B03147	Vented 19" panel 1U
	RP 2U - 2U Rack panel Code : B03144	19" panel 2U
	RP 2U/V - 2U ventilation rack panel Code : B03148	Ventilated 19" panel 2U
	TOLE1UV-NO Code : H0368	19" panel, height 1 unit, vented
	ETAGÈRE2U Code : H1626	Metal shelf height 2 units
	JB14 Code : B00926	JB SYSTEMS bass tube-Recessed bass-reflex tube for speaker
	JB7 Code : B00922	JB SYSTEMS Rubber foot for speaker
	SA65 Code : B00735	JB SYSTEMS 35mm metal adapter for speaker stands
	SPEAKER GRILL 12inch Code : B00911	Strong black metal grid
	SPEAKER GRILL 18inch Code : B00913	Strong black metal grid
	TE10 Code : B00915	Connection plate for loudspeaker with 2 terminal blocks
	A.CONTROLLER/ALU Code : B03187	Adapter for 2U/3U controllers
	MS-01 Code : B03160	JV CASE 4x M6x16 + 4x plastic washers + 4x cage nut 3mm
	MS-03 Code : B03164	JV CASE 20x black PVC washers M6
	MS-06 Code : B03178	JV CASE 12x M6 bolt x20 + 12x M6 nuts.
	MS-08 50x M4x16 bold-Mennekes Code : B03191	Set 50x M4 screws/nuts for mounting AC outlet.
	RACK DRAWER 3U Code : B03196	JV CASE 19" 3U drawer for rack
	RACK TRAY 2U Code : B03198	JV CASE 19" 2U shelf
	RP 1U - 1U Rack panel Code : B03143	19" panel 1U
	RP 1U/XLR - XLR (D-size) Rack panel Code : B008149	19" panel 1U for 12 x XLR
	RP 2U/PC-8 Code : B03181	19" 2 units rack panel for 8x Blue Power Outlet
	RP 3U - 3U Rack panel Code : B03145	19" panel 3U



LOUDSPEAKERS AND FILTERS

	SCX-12400 Code : B00850	SYNQ Powerful coaxial speaker of 400 W + 45 W of 12" + 1.75" and 60° x 40°.
	JODR-20 Code : H9900	1 inch compression driver for JOGGER60
	CRDR-20 Code : H9897	1.5 inch compression driver for CROSSER180
	SRDR12 Code : H10164	1.35 inch 50W 8 Ohm driver for SR12A and SR15A
	DIA/ACDR-30 Code : H8839	Diaphragm for ACDR-30
	SDR-50 Code : H9815	Driver for S8 and S10
	MOJOLINE-275 Code : H10586	2.75-inch tweeter for MOJO500LINE
	CDR-20 Code : H10315	1-inch 20W 8 Ohm tweeter for CR80A
	JB330 Code : B00801	85x85mm piezo tweeter
	JB660 Code : B00804	161x94mm dual piezo tweeter
	PTX34 Code : B00685	HF Driver: 1.50" - 50W 8 Ohm
	SXDR-50 Code : H10853	1.35-inch driver for SX12A and SX15A speakers
	AXO-AC08 Code : H9631	Passive filter for ACUTE08 passive
	AXO-S8 Code : H9725	Filter for S8
	AXO-COMPACT Code : H9399	2-way filter for COMPACT satellite
	AXO-SR10P Code : H10320	2-way filter for SR10P speaker
	AXO-SR15P Code : H10322	2-way filter for SR15P speaker
	AXOHL Code : H10591	2-way passive filter for HL-4
	CN-3 Code : B00615	High pass filter for 2-way system [X-over freq. : 7kHz, Slope: 12dB/oct RMS power: 100W]
	CN-9 Code : B00814	2 way professional filter [X-over freq. : 2kHz, Slope: 12dB/oct, RMS power: 200W]

	SCX-15450 Code : B00851	SYNQ Powerful 450W + 60W coaxial speaker of 15" + 1.75" and 60°x40°
	SPDR-20 Code : H9639	1 inch compression driver for SPRINTER120
	SRDR10 Code : H10163	1 inch driver for SR10A speaker
	ACDR-30 Code : H8838	Driver for COMPACT, SATCOM16, S6, D12 and D15 satellites
	OCDR-20 Code : H9400	COMPACT, SATCOM16, S6, D12 and D15 satellite engine
	HLTR Code : H10590	8 Ohm ribbon tweeter for HL-4
	CODR-20 Code : H10309	1-inch 20W 8 Ohm tweeter for COMPACT-500 satellite
	HT30 Code : B00806	1" capton 150W 8 Ohm bullet tweeter
	JB550 Code : B00803	187x80mm piezo tweeter
	PH2 Code : B00823	Horn for PTX34 and PTX44
	PTX44 Code : B00686	HF Driver: 1.75" - 50W 8ohm
	HT100 Code : B00807	1" capton 300W 8 Ohm bullet tweeter
	AXO-S6 Code : H9724	Filter for S6
	AXO-S10 Code : H9727	Filter for S10
	AXO-OCTAVE Code : H9394	2-way filter for OCTAVE satellite
	AXO-SR12P Code : H10321	2-way filter for SR12P speaker
	AXO-COMPACT500 Code : H10310	2-way filter for COMPACT-500 satellite
	CN-12 Code : B00815	2-way professional filter [X-over freq. : 1.8kHz, Slope: 12dB/oct, RMS power: 300W]
	CN-6 Code : B00813	High pass filter for 2-way system [X-over freq. : 4.5kHz, Slope: 18dB/oct RMS power: 100W].

LOUDSPEAKERS AND FILTERS

	CR25WB-200 Code : H10856	12-inch woofer for CR25A-COMBO
	SXWB15-200 Code : H10852	15-inch 250W woofer for SX15A
	iLINEw320 Code : H10765	HP 3" 20W for iLINE series columns
	SRWB12-350 Code : H10161	12" 350W 4 Ohms woofer for SR12A speaker
	SRWB12-350-8 Code : H10318	12-inch 350W 8 Ohm woofer for SR12P
	ACW08-104 Code : H8742	8-inch woofer for ACUTE-08 / AMP
	MIOSW6100 Code : H10151	6.5" 100W woofer for SYSTEM1 Sub
	SW8-150 Code : H9816	8-inch woofer for S8
	OWB6-100 Code : H9401	6.5" 8 Ohms 100 W woofer for COM-PACT and S6 satellites
	JOG6-30 Code : H9636	5-inch 30W 4 Ohm woofer for JOGGER50
	SPW10-120 Code : H9638	10-inch woofer 100W for SPRINTER120
	CRW6-60 Code : H10314	6.5-inch 80W 8 Ohm woofer for CR80A
	OWB12-400-8 Code : H9402	12-inch 400W 8 Ohm woofer for COMPACT subwoofer
	HLWB10 Code : H10589	10-inch 8 Ohm woofer for HL-10ASUB
	HLWB8 Code : H10588	8-inch 8 Ohm woofer for HL-08ASUB
	CUBW12-300 Code : H10728	12-inch 300W woofer for CUBsub112
	SRWB18-600 Code : H10733	18-inch woofer for SRSUB18A
	COW4-60 Code : H10308	4.75-inch 80W 8 Ohm woofer for COM-PACT-500 satellite
	PWX 12/200 Code : B00680	Woofer 12 inches / 200Wrms
	PWX 18/400 Code : B00683	18-inch / 400Wrms woofer
	SP-12/200 Code : B00666	12-inch / 200W woofer

	SXWB12-200 Code : H10851	12-inch 200W woofer for SX12A
	SRWB10-250 Code : H10160	10-inch 250W 4 Ohm woofer for SR10A speaker
	SRWB15-350 Code : H10162	15" 350W 4 Ohms woofer for SR15A speaker
	SRWB15-350-8 Code : H10319	15-inch 350W 8 Ohm woofer for SR15P
	ACW08-108 Code : H9629	8-inch 8 Ohm woofer for ACUTE08 passive
	MIOSW8150 Code : H10155	8" 150W woofer for SYSTEM2 Sub
	SW10-250 Code : H9726	10-inch woofer for S10
	OWB8-108 Code : H9630	8-inch 170W 8 Ohms woofer for Octave satellite
	JOG6-40 Code : H9901	5 1/4-inch woofer for JOGGER60
	CRW10-180 Code : H9899	10-inch woofer for CROSSER180
	OWB15-600 Code : H9106	15" woofer used in OCTAVE, SUB115-AMP, EX15S, EX215S subwoofers
	CW10-150 Code : H9301	10-inch woofer used in the CB-210
	HLWB4 Code : H10587	4-inch 8 Ohms woofer for HL-4
	MOJOLINE-08 Code : H10585	8-inch woofer for MOJ0500LINE
	CUBW08-150 Code : H10729	8-inch 150W woofer for CUBsub208
	COWB10-300 Code : H10307	10-inch 300W 4 Ohm woofer for COM-PACT-500 subwoofer
	PWX 10/200 Code : B00679	10-inch / 200Wrms woofer
	PWX 15/300 Code : B00681	15-inch / 300Wrms woofer
	SP-10/150 Code : B00665	10-inch / 150W woofer
	SP-15/250 Code : B00667	15-inch / 250W woofer



LAMPS

	LPAR36/4515 Code : H0132	GE lamp PAR36 6V 30W 4515
	LPAR56/WFL Code : H8662	GE lamp PAR56 240V 300W 37° x 20°
	MASTER LEDspot PAR20 DIM Code : B06501	PHILIPS LED LAMP 6W--2700K-E27-25°-DIM
	MASTER LEDspot PAR38 DIM Code : B06503	PHILIPS LED LAMP 13W-2700K-E27-25°-DIM
	GY9.5500 Code : H0296	Philips lamp CP82 240V 500W
	GX9.51000 Code : H0295	Lamp CP70 240V 1000W
	LR7S/118-500 Code : H9011	Lamp R7S 240V 500W 2900°K 2000H
	LHID-150 Code : H8984	Lamp type HID-150 95V 150W 6500 °K 1000H
	L2R Code : H10165	Philips® MSD Platinum 2R lamp
	LMSD-250/2 Code : H8994	Lamp type MSD-250-2 94V 250W 8000°K 2000H
	LBVM1 Code : H9006	Lamp type BVM 120V 300W 3200°K 150H
	LBVM3 Code : H9007	Lamp type BVM 240V 300W 3200°K 75H
	G6.3540036 Code : H0626	Osram lamp EVD 36V 400W
	LEFR Code : H9009	Lamp type EFR 15V 150W 3400°K 50H
	ELC25024 Code : H3119	Philips lamp ELC 24V 250W
	ENH250120 Code : H0177	Osram lamp ENH 120V 250W

	LPA56/MFL Code : H0131	Osram lamp PAR56 240V 300W
	MASTER LEDspot PAR16 DIM Code : B06500	PHILIPS LED LAMP 3.7W-2700K-GU10-25°-DIM
	MASTER LEDspot PAR30 DIM Code : B06502	PHILIPS LED LAMP 9.5W-2700K-E27-25°-DIM
	LED-GU10-5W-WW-38D Code : B02258	LED lamp GU10, 5W - 240Vac DIM, warm white, 38°
	GY9.5650 Code : H0297	GE lamp T26 240V 650W
	GX9.51000/T19 Code : H2590	Lamp T19 240V 1000W
	HPL 575-X LL 230v Code : B02171	GE Lighting Halogen lamp, no reflector, 575W/230V, sp. socket
	LHRI100 Code : H10432	OSRAM SIRIUS HRI lamp 100W,6000h,9000°K
	L5R Code : H10357	Philips MSD Platinum 5R lamp
	L15R Code : H10358	Philips MSD Platinum 15R lamp
	MSD250/2-05 Code : H3425	Osram lamp MSD 250W
	G6.35300110 Code : H1247	Osram lamp 64514 120V 300W
	G6.35300220 Code : H0628	Osram lamp 64516 240V 300W
	EFP10012 Code : H0624	Philips or Osram lamp EFP 12V 100W
	LELC Code : H9008	Lamp type ELC 24V 250W 3200°K 50H
	LELC/LD Code : H8986	lamp type ELC 24V 250W 3200 °K 300H
	LST/1500 Code : H9021	Lamp strobe type-3 1500W 5600°K 500H 120Hz max



WWW.AUDIOPHONY.COM



WWW.CONTEST-LIGHTING.COM



WWW.BRITEQ-LIGHTING.COM



WWW.JB-SYSTEMS.EU



WWW.SYNQ-AUDIO.COM



WWW.HILEC.EU

The advertised prices are VAT-inclusive prices, calculated with the VAT in force in the country of distribution.

See conditions at your retailer. Within the limits of available stocks. Information is subject to typographical errors. The technical specifications, photos, illustrations and prices in this catalogue are not binding. In order to improve our products, modifications can be made. In accordance with the legislation in force, it is up to each retailer to freely set its selling prices. Prices are subject to change without notice. The prices invoiced, in particular, are those of the tariff in force on the day of delivery. Catalogue in effect as of March 18, 2019.

AUDIOPHONY®, CONTEST®, JBSYSTEMS®, BRITEQ®, JV CASE® and SYNQ® are registered trademarks of HITMUSIC SAS and BEGLEC NV.

Any reproduction of the catalogue, even partial, or use of the logos or design of the intellectual property is prohibited, without prior written permission from HIT MUSIC SAS and/or BEGLEC NV.

Catalogue published by HITMUSIC SAS - Parc d'Activités CAHORS SUD - EN TESTE - 46230 FONTANES - France.
Product photo credits: Studio ZE and BEGLEC NV. - Ambience photocredits: © Shutterstock - Creation: Agence NOVO & HITMUSIC SAS

MKT-CATA2019
ANG / AVEC PRIX



3 662009 019499

code H10891