



[WWW.WHARFEDALEPRO.COM](http://WWW.WHARFEDALEPRO.COM)

IAG HOUSE, 13/14 GLEBE ROAD, HUNTINGDON, CAMBRIDGESHIRE,  
PE29 7DL, UK  
TEL: +44(0) 1480 452 561

# PRODUCT CATALOGUE 2021



## WHAT WE DO

At Wharfedale Pro we create the high quality, affordable sound reinforcement products for professional musicians, touring rigs and corporate installations. Our products are found in venues from superclubs to shopping malls around the world.

A combination of a passion for music and stringent quality control stemming from one of the world's most famous loudspeaker company's means that power, reliability and great value are what we're known for, and we're proud of it.

## WHERE IT CAME FROM

Wharfedale Pro has a heritage built on supreme quality audio spanning back to the 1930s. Founded in Britain by Gilbert Briggs in 1932, Wharfedale was initially a home hi-fi loudspeaker manufacturer, and still is today as a separate brand.

## THE TEAM

Our designers are pooled from the finest within each of their disciplines. R&D takes place on an international scale with designers and electronics engineers from the United Kingdom, Japan, China and Hong Kong.

## MANUFACTURING QUALITY

Our fully ISO9001 approved factory utilises the most advanced manufacturing equipment including a full production suite for our own tooling. Such is the level of our vertical integration that from pulp to finished product, from chassis manufacture to winding the voice coils and manufacturing the PCBs for the crossover - 95% is done in-house.

## IRIS X DRIVER TECHNOLOGIES

The coil size and electrical sensitivity of a loudspeaker transducer is critical to its performance. Many Wharfedale Pro loudspeakers now include our proprietary IRIS X design which delivers Increased coil Radius and Increased electrical Sensitivity. The radius of the coil ensures smooth heat dissipation during prolonged high volume use, while the increased electrical sensitivity ensures that the transducer converts as much electrical power into sound output as the laws of physics allow.

A hot transducer wastes energy, risks damage and distorts. IRIS X reduces this through improved heat dissipation and improved efficiency.

In real-world terms, IRIS X transducers deliver higher SPL with less distortion. They lead the market with specifications and are designed and built entirely within Wharfedale Pro.

**I** Increased  
**R** Radius  
**I** Increased  
**S** Sensitivity



## Active PA Speakers

<b>NEW</b> TOURUS SERIES	4
TITAN-AX	8
TITAN 8A MKII	10
TITAN SUB A12	13
<b>NEW</b> TYPHON SERIES	14
<b>NEW</b> T-SUB-AX15B	18
DVP-AX	20
EVP-XPM	24
ISOLINE	25
EZ-12A / 15A	26
DELTA-AX	28

## Passive PA Speakers

TITAN 8	31
TITAN-X	32
TITAN-Z	33
DVP-X	36
IMPACT-X	40
EVP-X MKII	44
EVO-X	48
DELTA-X	52
<b>NEW</b> REASON-X	56
FOCUS SERIES	60

## Line Array

<b>NEW</b> WLA-210XF / WLA-28F SYSTEMS	62
<b>NEW</b> WLA-312X SYSTEM	64
WLA-210X SYSTEM	66
WLA-28 SYSTEM	68
WLA-25 SYSTEM	70
WLA SERIES SUBWOOFERS	72
WLA-12M / 15M	73

## Installation Speakers

WH NEO	77
<b>NEW</b> I SERIES	78
SIGMA SERIES	80
PROGRAMME SERIES	84
SI-X SERIES	86
80 AND 90 SERIES	88

## Amplifiers

XR SERIES	90
DP SERIES	92
<b>NEW</b> DP-D SERIES	94
CPD SERIES	96
MP SERIES	98

## Mixers

CONNECT SERIES	100
SL SERIES	102
FORCE 12	103
PMX	104

## Signal Processors

VERSADRIVES	106
-------------	-----

## Microphones

DM5.0 / DM-57 MICS	108
KMD-7 PACK	110
WF-300	111
AEROLINE VOCAL	112

## Accessories

BRACKETS	113
POLES AND USEFUL ACCESSORIES	114
PROTECTIVE BAGS	115



# Tourus Series

MULTIPLE INPUTS... WITH MAXIMUM POWER OUTPUT



Tourus 15" Active



Tourus 12" Active



Tourus 8" Active

Constructed of durable polypropylene and using a full-face steel front grille, Tourus loudspeakers are robust and versatile - ideal for DJ's, musicians and installations.

Custom Wharfedale Pro drivers have been used. All models use a class-leading 1.75" HF compression driver to ensure clear and accurate high frequency performance. Meanwhile the large 2.0" voice coils used in the 12" and 15" LF drivers give efficient power handling, even at extreme volumes.

12" and 15" models are bi-amplified using Class D for the LF and a newly designed Class AB amplifier for the HF. This combination gives a great power to price ratio. The 8" model uses Class D which delivers the power needed, but at a reduced weight.

Simple operation is the key though - with +/-12 dB treble and bass controls and straightforward connectivity, even the most inexperienced user can achieve great sound.

## AROUND THE BACK

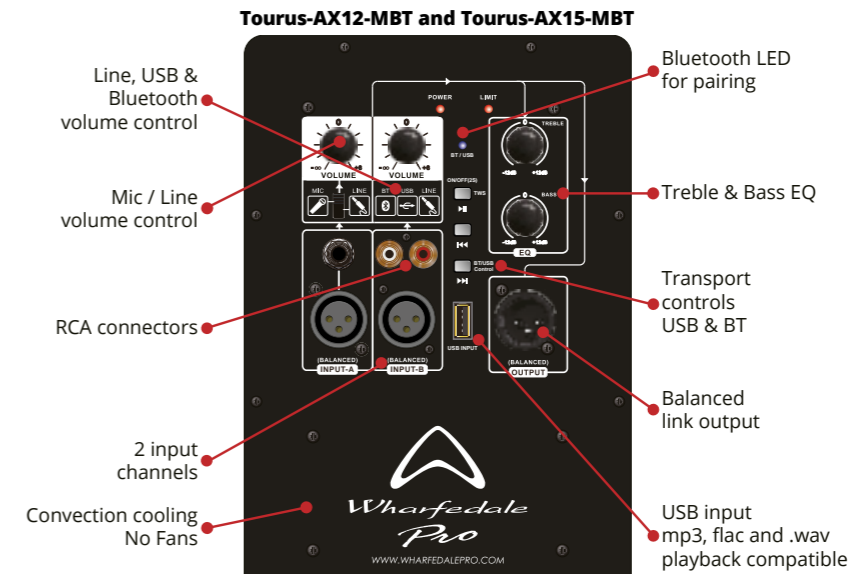

## BI-AMPLIFIED

Tourus active loudspeakers contain 2 discrete amplifiers. This ensures the best matching with the custom transducers.

In the 12" and 15" models, the HF component is driver by a Class AB amplifier while the LF is driven by a Class D amplifier. This gives a practical balance between weight, cost and power.

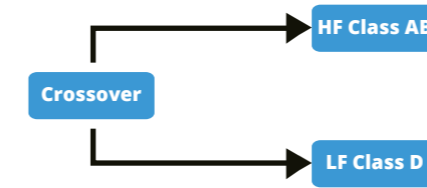

## No Fans = silent operation and high reliability

sssssh !

The two amplifiers inside a Tourus are extremely efficient. So efficient that they can use convection cooling. This means that there are no fans!

Fans inside loudspeakers can add to operational noise, weight, price and canlead to reliability issues.

Tourus has no fan!

Sssssh! - Silent and reliable operation.



## Large 1.75" HF voice coil

Tourus loudspeakers use the largest HF voice coils in their class.

A custom made Wharfedale Pro compression driver delivers crisp and precise high frequencies, even at extreme volumes.



## Optional Tourus Soft cover

With soft internal padding these optional accessories are ideal for simple transportation or as a dust cover when the Tourus is not being used.

The Tourus carry handles are easily accessible even when it is inside its Tourus Soft cover.



## SPECIFICATIONS

Model Name	Tourus-AX8	Tourus-AX8-MBT	Tourus-AX12
System Type	Active 8" 2-way Bi-Amplified	Active 8" 2-way Bi-Amplified	Active 12" 2-way Bi-Amplified
Frequency Response (+/-3 dB)	65-20 kHz	65-20 kHz	55-20 kHz
Sensitivity @ 1w / 1 meter	95 dB	95 dB	96 dB
Maximum SPL (peak @ 1 meter)	124 dB	124 dB	128 dB
<b>Low Frequency Transducer</b>			
Size (mm / inches)	203 mm / 8"	203 mm / 8"	305 mm / 12"
Coil Size (mm / inches)	38.86 mm / 1.53"	38.86 mm / 1.53"	50.8 mm / 2.0"
Impedance	4 Ω	4 Ω	4 Ω
<b>High Frequency Transducer</b>			
Type	Compression Driver	Compression Driver	Compression Driver
Coil Size (mm / inches)	44.5 mm / 1.75"	44.5 mm / 1.75"	44.5 mm / 1.75"
Exit Size (mm / inches)	25 mm / 1"	25 mm / 1"	25 mm / 1"
Diaphragm Material	Titanium	Titanium	Titanium
Impedance	8 Ω	8 Ω	8 Ω
High Frequency Coverage (H x V)	90° x 60°	90° x 60°	90° x 60°
Amplifiers	Class D	Class D	HF Amp Class AB : LF Amp Class D
Low-Frequency Power Amplifier	150 w Continuous / 300 w Peak	150 w Continuous / 300 w Peak	250 w Continuous / 500 w Peak
High-Frequency Power Amplifier	100 w Continuous / 200 w Peak	100 w Continuous / 200 w Peak	100 w Continuous / 200 w Peak
<b>Electronic Crossover</b>			
Crossover Frequency	2.6 kHz	2.6 kHz	HI PASS 2.5 kHz LOW PASS 2.5 kHz
<b>Controls</b>			
Equalization	+/-12 dB Gain for bass and treble	+/-12 dB Gain for bass and treble	+/-12 dB Gain for bass and treble
<b>Amplifier Protection</b>			
Power On Protection	Power switch on / off mute	Power switch on / off mute	Power switch on / off mute
Thermal Protection	Amplifier shutdown, auto reset	Amplifier shutdown, auto reset	Amplifier shutdown, auto reset
Driver, DC and Short Protection	Yes	Yes	Yes
Limiter Indicator	Red LED	Red LED	Red LED
Power Indicator	Green LED / Blue LED(LOGO)	Green LED / Blue LED(LOGO)	Green LED
Input type	Balanced / unbalanced	Balanced / unbalanced / Bluetooth / USB	Balanced
Input Connectors	TRS JACK / FEMALE XLR / RCA	TRS JACK / FEMALE XLR / RCA / USB	2 x TRS JACK, 2 x RCA AND 2 x FEMALE XLR
Input Impedance	47 KΩ Balanced	47 KΩ Balanced	47 KΩ Balanced
Maximum Input Level	5 V	5 V	5 V
Line Input Sensitivity	-10 dB	-10 dB	-10 dB
Mic Input Sensitivity	-40 dB	-40 dB	-40 dB
Line Output Connector	MALE XLR	MALE XLR	MALE XLR
<b>AC Power details</b>			
Power Supply	SMPS	SMPS	SMPS
AC Power Options	100 V - 120 V and 220 V - 240 V	100 V - 120 V and 220 V - 240 V	100 V - 120 V and 200 V - 240 V
Power On Indicator	LED	LED	LED
Rigging / Bracket / Mounting Options	4 x M8 35 mm Pole-mount with lock screw 3 carry handles (one on each side, one on top) Optional wall-mount bracket (WPB-2)	4 x M8 35 mm Pole-mount with lock screw 3 carry handles (one on each side, one on top) Optional wall-mount bracket (WPB-2)	4 x M8 35 mm Pole-mount with lock screw 3 carry handles (one on each side, one on top) Optional wall-mount bracket (WPB-2)
<b>Enclosure</b>			
Enclosure Material	Injection Moulded Polypropylene	Injection Moulded Polypropylene	Injection Moulded Polypropylene
Colour	black	black	black
Grille	1.2 mm steel	1.2 mm steel	1.2 mm steel
<b>Dimensions (Unpacked)(mm / inches)</b>			
Height	421.4 mm / 16.6"	421.4 mm / 16.6"	603 mm / 23.7"
Width - Front	259 mm / 10.2"	259 mm / 10.2"	377 mm / 14.8"
Width - Rear	171.9 mm / 6.7"	171.9 mm / 6.7"	217 mm / 8.54"
Depth	263.2 mm / 10.4"	263.2 mm / 10.4"	347 mm / 13.7"
<b>Dimensions (packed)(mm / inches)</b>			
Height	470 mm / 18.5"	470 mm / 18.5"	666 mm / 26.2"
Width	315 mm / 12.4"	315 mm / 12.4"	430 mm / 16.9"
Depth	307 mm / 12.1"	307 mm / 12.1"	408 mm / 16.1"
<b>Weight</b>			
Net Weight (kg / lbs)	8.0 kg / 17.6 lbs	8.0 kg / 17.6 lbs	15.0 kg / 33.0 lbs
Gross Weight (kg / lbs)	9.2 kg / 20.24 lbs	9.2 kg / 20.24 lbs	17.0 kg / 37.4 lbs

## SPECIFICATIONS

Model Name	Tourus-AX12-MBT	Tourus-AX15	Tourus-AX15-MBT
System Type	Active 12" 2-way Bi-Amplified	Active 15" 2-way Bi-Amplified	Active 15" 2-way Bi-Amplified
Frequency Response (+/-3 dB)	55-20 kHz	50-20 kHz	55-20 kHz
Sensitivity @ 1w / 1 meter	96 dB	97 dB	97 dB
Maximum SPL (peak @ 1 meter)	128 dB	130 dB	130 dB
<b>Low Frequency Transducer</b>			
Size (mm / inches)	305 mm / 12"	381 mm / 15"	381 mm / 15"
Coil Size (mm / inches)	50.8 mm / 2.0"	50.8 mm / 2.0"	50.8 mm / 2.0"
Impedance	4 Ω	4 Ω	4 Ω
<b>High Frequency Transducer</b>			
Type	Compression Driver	Compression Driver	Compression Driver
Coil Size (mm / inches)	44.5 mm / 1.75"	44.5 mm / 1.75"	44.5 mm / 1.75"
Exit Size (mm / inches)	25 mm / 1"	25 mm / 1"	25 mm / 1"
Diaphragm Material	Titanium	Titanium	Titanium
Impedance	8 Ω	8 Ω	8 Ω
High Frequency Coverage (H x V)	90° x 60°	90° x 60°	90° x 60°
Amplifiers	HF Amp Class AB : LF Amp Class D	HF Amp Class AB : LF Amp Class D	HF Amp Class AB : LF Amp Class D
Low-Frequency Power Amplifier	250 w Continuous / 500 w Peak	350 w Continuous / 700 w Peak	350 w Continuous / 700 w Peak
High-Frequency Power Amplifier	100 w Continuous / 200 w Peak	100 w Continuous / 200 w Peak	100 w Continuous / 200 w Peak
<b>Electronic Crossover</b>			
Crossover Frequency	HI PASS 2.5 kHz LOW PASS 2.5 kHz	HI PASS 2.4 kHz LOW PASS 2.4 kHz	HI PASS 2.4 kHz LOW PASS 2.4 kHz
<b>Controls</b>			
Equalization	+/-12 dB Gain for bass and treble	+/-12 dB Gain for bass and treble	+/-12 dB Gain for bass and treble
<b>Amplifier Protection</b>			
Power On Protection	Power switch on / off mute	Power switch on / off mute	Power switch on / off mute
Thermal Protection	Amplifier shutdown, auto reset	Amplifier shutdown, auto reset	Amplifier shutdown, auto reset
Driver, DC and Short Protection	Yes	Yes	Yes
Limiter Indicator	Red LED	Red LED	Red LED
Power Indicator	Green LED	Green LED	Green LED
Input type	Balanced / BT / USB	Balanced	Balanced / BT / USB
Input Connectors	2 x TRS JACK, 2 x RCA AND 2 x FEMALE XLR	2 x TRS JACK, 2 x RCA AND 2 x FEMALE XLR	2 x TRS JACK, 2 x RCA AND 2 x FEMALE XLR
Input Impedance	47 KΩ Balanced	47 KΩ Balanced	47 KΩ Balanced
Maximum Input Level	5 V	5 V	5 V
Line Input Sensitivity	-10 dB	-10 dB	-10 dB
Mic Input Sensitivity	-40 dB	-40 dB	-40 dB
Line Output Connector	MALE XLR	MALE XLR	MALE XLR
<b>AC Power details</b>			
Power Supply	SMPS	SMPS	SMPS
AC Power Options	100 V - 120 V and 220 V - 240 V	100 V - 120 V and 220 V - 240 V	100 V - 120 V and 200 V - 240 V
Power On Indicator	LED	LED	LED
Rigging / Bracket / Mounting Options	4 x M8 35 mm Pole-mount with lock screw 3 carry handles (one on each side, one on top) Optional wall-mount bracket (WPB-2)	4 x M8 35 mm Pole-mount with lock screw 3 carry handles (one on each side, one on top) Optional wall-mount bracket (WPB-2)	4 x M8 35 mm Pole-mount with lock screw 3 carry handles (one on each side, one on top) Optional wall-mount bracket (WPB-2)
<b>Enclosure</b>			
Enclosure Material	Injection Moulded Polypropylene	Injection Moulded Polypropylene	Injection Moulded Polypropylene
Colour	black	black	black
Grille	1.2 mm steel	1.2 mm steel	1.2 mm steel
<b>Dimensions (Unpacked)(mm / inches)</b>			
Height	603 mm / 23.7"	693 mm / 27.3"	693 mm / 27.3"
Width - Front	377 mm / 14.8"	455 mm / 17.9"	455 mm / 17.9"
Width - Rear	217 mm / 8.54"	262 mm / 10.3"	262 mm / 10.3"
Depth	347 mm / 13.7"	401.8 mm / 15.1"	401.8 mm / 15.1"
<b>Dimensions (packed)(mm / inches)</b>			
Height	666 mm / 26.2"	762 mm / 30.0"	762 mm / 30.0"
Width	430 mm / 16.9"	508 mm / 20.0"	508 mm / 20.0"
Depth	408 mm / 16.1"	425 mm / 16.7"	425 mm / 16.7"
<b>Weight</b>			
Net Weight (kg / lbs)	15.0 kg / 33.0 lbs	19.2 kg / 42.2 lbs	19.2 kg / 42.2 lbs
Gross Weight (kg / lbs)	17.0 kg / 37.4 lbs	22.0 kg / 48.4 lbs	22.0 kg / 48.4 lbs



# TITAN-AX

ACTIVE, VERSATILE AND LIGHTWEIGHT PA.



Titanium Compression Driver



Lightweight



Internal DSP



Ready for Rigging



Moisture Rejection



100° x 80° Hybrid Symmetry horn



For many years the name 'Titan' has become the benchmark for portable and versatile loudspeakers. It's a name that is trusted by artists and venues around the world, day in, day out.

However, technology advances... and so do we! Our all-new Titan-AX12 and AX15 active loudspeakers therefore now feature our cutting edge 6-position DSP engine and all-new HF and LF drivers. No other competitive model features such powerful and effective DSP or such advanced transducers.

## IP54 Certified

IP54 certification assures that the product has

- Limited protection against dust ingress.
- Protection against splash water from any direction.

This makes the Titan AX12 and Titan AX15 ideal for installations into hostile environments. Complete peace of mind and protection.

## Active PA Speakers



## DSP

The all-new DSP engine provides sophisticated internal loudspeaker management functions. These include limiting, compression, signal delay, dynamic boost, dynamic cut, crossover control and parametric EQ. Micro adjustments within each parameter ensure sonic clarity over the full frequency range.

We've optimised these DSP parameters to create 6 user-friendly settings including Monitor, Speech, Bass, Punch and an exclusive mode called "Live". This Live mode applies different DSP settings to each of the 2 inputs - perfect for solo entertainers using a mic and a line level source.

## INDOOR AND OUTDOOR INSTALLATION

The Titan-AX12 and AX15 feature moisture proof woofers which can withstand outdoor and extreme conditions. Additional protection can be found with the optional Titan Tourbags.

These custom made speaker bags have an unzippable front panel for maximum protection.



## Titan-AX uses our latest IRIS X4 HF compression drivers.

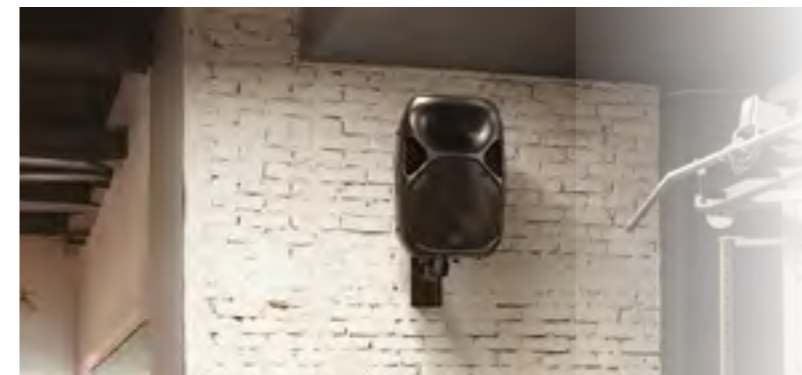

I R I S  
Increased Radius  
Increased Sensitivity



- New IRIS X4 HF Drivers have been honed acoustically for high-frequency detail and power
- New LF Drivers reject moisture for resistance in all environments
- New Proprietary 100° x 80° Hybrid Symmetry Horn design
- New category leading DSP functions
- New tweaked laminar rib structure
- Integral mixer functions
- AX12 - 300 W programme / 600 watts peak
- AX15 - 420 W programme / 840 watts peak
- Class D Bi-amplified
- Tough, yet lightweight Dynamic Polypropylene cabinet with rubber padded handles
- 10 x M8 rigging points and integral tripod stand adapter
- Rugged protective grille and top-stacking receptacles
- Trapezoid design for arrays as well as stage monitor applications
- Available in black or white
- Titan Tourbags available



# TITAN 8A MKII

VERSATILE, LIGHTWEIGHT AND POWERED.



Lightweight



Moisture Rejection



Ready for Rigging



90° x 60° elliptical waveguide



Black and white versions

The Titan 8A MKII active PA speaker combines the Titan technology, materials and design topology, including a titanium compression driver and heavy-duty cast-frame woofer, to ensure absolute accuracy, high output and the smooth, wide dispersion of the critical mid and high frequency ranges. Whilst being ultra-compact and light weight it lends itself to a whole host of audio applications from gym installations, DJ booth monitors and public address.



## INDOOR AND OUTDOOR INSTALLATION

Although the product weight and rubberised handles are perfect for the mobile musician, this technology also lends itself to installations where weight is an issue, not to mention that the polypropylene material and moisture proof woofers can withstand outdoor conditions.

Additional protection can be found with the Titan Tourbags, custom made speaker bags with an unzippable front panel meaning your Wharfedale Pro loudspeaker is always protected.

Titan 8A MKII is available in Black or White.

## IP54 Certified

- IP54 certification assures that the product has
  - Limited protection against dust ingress.
  - Protection against splash water from any direction.



This makes the Titan 8a MKII ideal for installations into hostile environments. Complete peace of mind and protection.

## Poles, mounts and brackets

On the base of the Titan Series is a convenient pole mount socket that is used for easy mounting on a standard 35 mm diameter speaker poles. Cord wrap and cable anchor features are also moulded into the enclosure to keep things tidy.

Threaded rigging points are provided for a variety of safe flying configurations and Titan 8A MKII can be wall mounted using the optional WPB-T8.



Optional WPB-T8 mounting kit

- 180 W AES (RMS) / 360 W Peak
- 124 dB Max SPL
- 70 Hz - 20 kHz frequency response
- Custom Heavy duty moisture-proof 8" LF driver
- Proprietary 90° x 60° Elliptical Wave Guide Horn design
- High-end Titanium HF Compression Driver
- 2-band Hi / Low shelf EQ



- Multiple M6, M8 & M10 rigging points and integral tripod stand adapter
- Rugged protective grille and top-stacking receptacles
- Trapezoid shape for arrays as well as stage monitor applications
- Tough, yet lightweight Polypropylene molded cabinet with rubber padded handles



# Titan Sub A12

DELIVERING LOW END PUNCH IN A PORTABLE PACKAGE



Model Name	Titan 8A MKII	Titan-AX12	Titan-AX15
System Type	Active 8" 2-way Bi-Amplified	Active 12" 2-way Bi-Amplified	Active 15" 2-way Bi-Amplified
Frequency Response (+/-3 dB)	70 Hz-20 kHz	55 Hz-20 kHz	50 Hz-20 kHz
Frequency Range (-10 dB)	65 Hz-20 kHz	50 Hz-20 kHz	40 Hz-20 kHz
Calculated Maximum SPL @1 m	124 dB	128 dB	129 dB
LF Transducer Size (mm / inches)	205 mm / 8"	305 mm / 12"	381 mm / 15"
Coil Size (mm / inches)	38.86 mm / 1.53"	64.26 mm / 2.5"	75 mm / 3.0"
HF Transducer Type	Compression Driver	Compression Driver	Compression Driver
Coil Size (mm / inches)	25 mm / 1"	44 mm / 1.75"	44 mm / 1.75"
Exit Size (mm / inches)	30 mm / 1.2"	25 mm / 1"	25 mm / 1"
Diaphragm Material	Mylar	Titanium	Titanium
Nominal Coverage (H x V)	Elliptical waveguide 90° x 60°	Hybrid Symmetry Horn 100° x 80°	Hybrid Symmetry Horn 100° x 80°
<b>Amplifiers</b>			
Low-Frequency Power Amplifier RMS/Peak Watts	150/300 W (Class D)	250/500 W (Class D)	350/700 W (Class D)
High-Frequency Power Amplifier RMS/Peak Watts	30/60 W (Class D)	50/100 W (Class D)	70/140 W (Class D)
Controls---EQ	High (±10 dB)10 kHz Shelving Low (±10 dB) 100 Hz Shelving	Note - EQ changed by DSP knob	Note - EQ changed by DSP knob
DSP	None	6 user presets	6 user presets
Hi Pass switch	-	90 Hz	90 Hz
Amplifier Protection / Thermal protection	Yes	Yes	Yes
Low Line Voltage Shut Down	60% Nominal line voltage	60% Nominal line voltage	60% Nominal line voltage
Driver Protection	Independent LF and HF limiters	Independent LF and HF limiters	Independent LF and HF limiters
DC Protection / Short Protection	Yes	Yes	Yes
Clip Limiter	Turns on ~150 W output	Turns on ~250 W output	Turns on ~350 W output
Limiter Indicator / Power Indicator	Red LED / Green LED	Red LED / Green LED	Red LED / Green LED
<b>Connectors</b>			
Input - type	Switchable balanced mic/line level	Switchable balanced mic/line level (Chan 1)	Switchable balanced mic/line level (Chan 1)
Input Connector	XLR 1/4"Combo Jack	2 * XLR & 2 * 1/4" jack (Chan 1 Line/MIC)	2 * XLR & 2 * 1/4" jack (Chan 1 Line/MIC)
Line Output Connector	Switchable LOOP/MIX Balanced Female XLR	Switchable LOOP/MIX Balanced Female XLR	Switchable LOOP/MIX Balanced Female XLR
AC Power Supply	SMPS	SMPS	SMPS
AC Power Options	AC100-120 V~/220-240 V~,50/60 Hz	AC100-120 V/220-240 V- 50/60 Hz	AC100-120 V/220-240 V- 50/60 Hz
<b>Hardware</b>			
Rigging / Bracket / Mounting Options	8 M6 threaded inserts inc 4 M6 threaded inserts on base in OmniMount 30.0-type footprint	10 M8 threaded inserts including 4 M8 threaded inserts on bottom in OmniMount 30.0-type footprint	10 M8 threaded inserts including 4 M8 threaded inserts on bottom in OmniMount 30.0-type footprint
	35 mm with lock screw	35 mm receptacle with lock screw	35 mm receptacle with lock screw
	1 carry handle on side	2 carry handles (one on each side)	2 carry handles (one on each side)
	Optional wall-mount bracket	Optional wall-mount bracket	Optional wall-mount bracket
LED Horn lighting (On/Off switch)	Yes	Yes	Yes
Enclosure Material and finish	Injection Moulded Polypropylene	Injection Moulded Polypropylene	Injection Moulded Polypropylene
Colour Options	Grey / White / Black	Black / White	Black / White
Grille Material & Finish	1.2 mm steel	1.2 mm steel	1.2 mm steel
<b>Dimensions - Unpacked - Height</b>	396 mm / 15.59"	582.7 mm / 22.9"	728.5 mm / 28.7"
Width Front	266 mm / 10.47"	384.6 mm / 15.1"	480.6 mm / 18.9"
Depth	221 mm / 8.7"	318.6 mm / 12.5"	395.6 mm / 15.6"
<b>Dimensions - packed - Height</b>	463 mm / 18.2"	663 mm / 26.1"	830 mm / 32.7"
Width Front	325 mm / 12.8"	435 mm / 17.1"	514 mm / 20.2"
Depth	282 mm / 11.1"	408 mm / 16.1"	489 mm / 19.3"
Net Weight (kg / lbs)	6.25 kg / 13.75 lbs	12.4 kg / 27.28 lbs	22.94 kg / 50.3 lbs
Gross Weight (kg / lbs)	8.75 kg / 17.94 lbs	15.5 kg / 34.1 lbs	27.7 kg / 60.9 lbs



The Wharfedale Pro Titan Sub-A12, is a powerful active subwoofer system for small to medium active PA speaker setups. It utilises a 12" active reflex subwoofer to generate 250 W RMS (500 W peak) power, with a frequency response of 55-200 Hz. It's a perfect match teamed up with the Wharfedale Titan 8A MKII for an incredibly portable sound reinforcement system.



## 12" active reflex subwoofer

- Low-frequency power amplifier (Class D) 250 w rms, 500 w peak
- Preset integral peak limiter prevents signal distortion and amplifier clipping
- Integral phase switch with 0° and 180° selections
- High pass frequency selection:150 Hz
- Thermal, dc fault and short circuit protection
- XLR / 1/4 " combo jack inputs
- Balanced line level output
- Preset limiter prevents signal clipping
- Integral pole mount adapter



Model Name	Titan Sub A12
System Type	Active 12" Reflex Subwoofer
Frequency Response (+/-3 dB)	55 Hz-200 Hz
Frequency Range (-10 dB)	50 Hz-200 Hz
Calculated Maximum SPL @1 m	127 dB
LF Transducer Size (mm / inches)	305 mm / 12"
Coil Size (mm / inches)	64.26 mm / 2.5"
<b>Amplifiers</b>	
Low-Frequency Power Amplifier RMS/Peak Watts	250/500 W (Class D)
High-Frequency Power Amplifier RMS/Peak Watts	-
Controls---EQ	Crossover filter : 80 Hz - 200 Hz (adjustable)
DSP	-
Hi Pass switch	150 Hz
Amplifier Protection / Thermal protection	Yes
Low Line Voltage Shut Down	60% Nominal line voltage
Driver Protection	Independent LF limiters
DC Protection / Short Protection	Yes
Clip Limiter	Tums on ~250 W output
Limiter Indicator / Power Indicator	Red LED / Green LED
<b>Connectors</b>	
Input - type	0 / 180° phase switch
Input Connector	2 * XLR 1/4" Combo Jack
Line Output Connector	Hi Pass out : 2 * Balanced XLR
AC Power Supply	SMPS
AC Power Options	AC100-120 V~/220-240 V~,50/60 Hz
<b>Hardware</b>	
Rigging / Bracket / Mounting Options	35 mm socket
	2 carry handles (one on each side)
LED Horn lighting (On/Off switch)	No
Enclosure Material and finish	15 mm MDF
Colour Options	Grey / Black
Grille Material & Finish	1.2 mm steel
<b>Dimensions - Unpacked - Height</b>	360 mm / 14.2"
Width Front	493 mm / 19.4"
Depth	431 mm / 16.9"
<b>Dimensions - packed - Height</b>	440 mm / 17.3"
Width Front	560 mm / 22.0"
Depth	440 mm / 17.3"
Net Weight (kg / lbs)	22.31 kg / 49.0 lbs
Gross Weight (kg / lbs)	26.26 kg / 57.8 lbs



# Typhon Series

THE NEW FACE OF ACTIVE PA.



Titanium Compression Driver



Lightweight



Internal DSP



Ready for Rigging



Moisture Rejection



100° x 80° Hybrid Symmetry horn



**720 w Continuous  
1440 w peak**



Typhon 12" models



Typhon 8" models

In ancient mythology, Typhon was a giant who brought fear to his enemies. From a similar era to the Titans, it is said that the God Typhon had the power to create and control massive wind tornadoes in his battles. Mythology also often refers to him as being invincible.

The Typhon series are powerful, portable and versatile active loudspeakers available as both an 8" and a 12" model. Suitable for many professional audio applications a Typhon is ideal for DJ's, live bands, small to medium size stages, installations and houses of worship.

## Both 8" and 12" Typhons feature....

- 720 w continuous (1440 w peak) amplification
- Fresh new designs with full frontal steel grilles
- Top and bottom practical handles
- Bluetooth model available Typhon-AX12-BT & Typhon-AX8-BT
- Bi-amplified with Class D amps
- 4 position DSP

## Active PA Speakers



## Typhon Bluetooth models

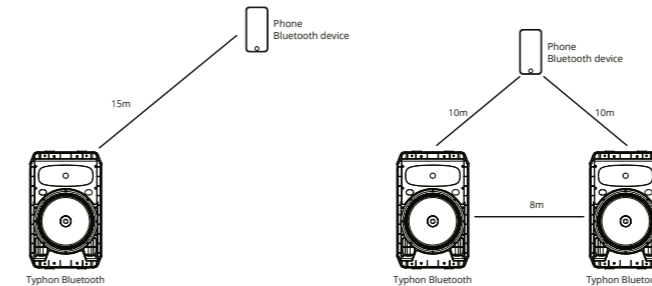

The Typhon Bluetooth models feature all the same DSP, amplifiers and drivers as the non-Bluetooth models, but also come with Bluetooth. This makes it easy to connect wirelessly to the Typhon using a Bluetooth enabled mobile phone or tablet. The Bluetooth uses the aptX protocol which ensures the highest quality digital audio transmission. Wire-free with simple pairing.

The Bluetooth models also have a TWS Stereo Link mode. Simply connect your Bluetooth device to the first of your Bluetooth Typhon's and then press 'ST Link'. The first Typhon will communicate with the second Typhon and create a wire-free stereo pair.

## Typhon-AX8 / Typhon-AX8-BT

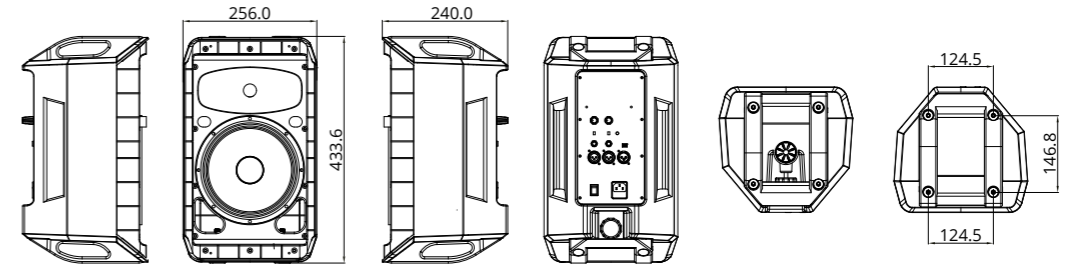

## Typhon-AX12 / Typhon-AX12-BT

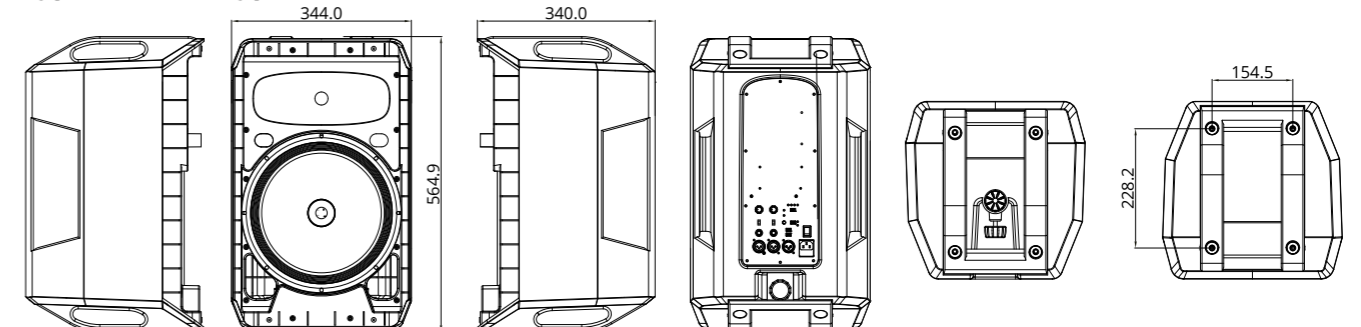



# Typhon Series

THE NEW FACE OF ACTIVE PA.



Titanium Compression Driver



Lightweight



Internal DSP



Ready for Rigging



Moisture Rejection



100° x 80° Hybrid Symmetry horn

## ADVANCED DSP

The DSP inside all models of Typhon is extremely powerful. Here we describe the 4 modes and their possible real-life applications.

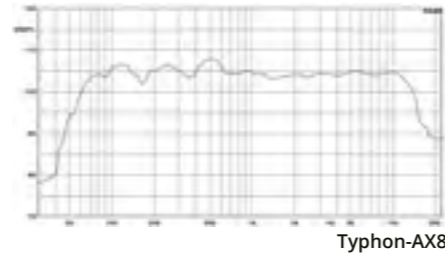

### FLAT

The Flat mode is 'the truth'. This mode is ideal for when connecting guitar effects processors directly to a Typhon. Full Range, Flat Response. Simply YOUR sound.

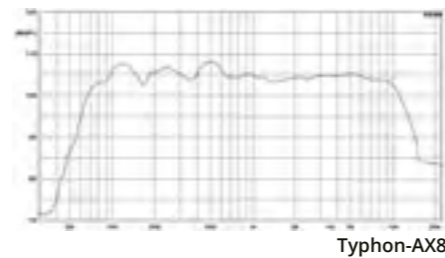

### MONITOR

This mode rolls off low frequencies which are not needed when a Typhon is on the floor. High frequencies are also attenuated to reduce risk of feedback.

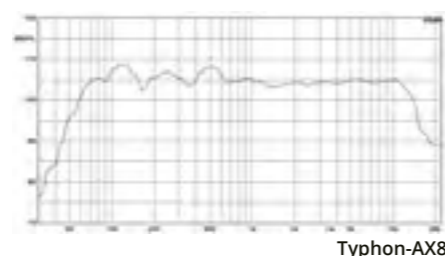

### BASS

By pushing the bass frequencies, this mode is ideal when a Typhon is being used at lower volumes. It delivers a more powerful sound without having to turn the volume up.

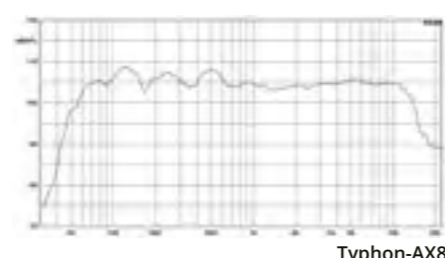

### PUNCH

A 'crisp' and 'tight' DSP mode which gives the impression of power. Use this when you really need to cut through.

## Active PA Speakers



Model Name	Typhon-AX8	Typhon-AX8-BT	Typhon-AX12	Typhon-AX12-BT
System Type	Active 8" 2-way	Active 8" 2-way with Bluetooth	Active 12" 2-way	Active 12" 2-way with Bluetooth
Frequency Response (+/-3 dB)	65 Hz-20 kHz	65 Hz-20 kHz	55 Hz-20 kHz	55 Hz-20 kHz
Frequency Range (-10 dB)	60 Hz-20 kHz	60 Hz-20 kHz	50 Hz-20 kHz	50 Hz-20 kHz
Maximum SPL (peak @1 m)	127 dB	127 dB	129 dB	129 dB
Sensitivity (@ 1 W / 1 m)	96 dB	96 dB	98 dB	98 dB
<b>Low Frequency Transducer</b>				
Size (mm / inches)	203.8 mm / 8"	203.8 mm / 8"	305 mm / 12"	305 mm / 12"
Voice-Coil Size (mm / inches)	65 mm / 2.5"	65 mm / 2.5"	65 mm / 2.5"	65 mm / 2.5"
Rated Impedance	4 Ω	4 Ω	4 Ω	4 Ω
<b>High Frequency Transducer</b>				
HF Driver Type	Compression Driver	Compression Driver	Compression Driver	Compression Driver
Coil Size (mm / inches)	44 mm / 1.75"	44 mm / 1.75"	44 mm / 1.75"	44 mm / 1.75"
Exit Size (mm / inches)	25 mm / 1"	25 mm / 1"	25 mm / 1"	25 mm / 1"
Diaphragm Material	Titanium	Titanium	Titanium	Titanium
Rated Impedance	8 Ω	8 Ω	8 Ω	8 Ω
Nominal Coverage (H x V)	Hybrid Symmetry 100° x 80°	Hybrid Symmetry 100° x 80°	Hybrid Symmetry 100° x 80°	Hybrid Symmetry 100° x 80°
<b>Amplifiers</b>				
Power Rating	2 x Class D 1440 W Peak (1200W LF + 240 W HF), 720 W Continuous (600 W LF + 120 W HF)	2 x Class D 1440 W Peak (1200W LF + 240 W HF), 720 W Continuous (600 W LF + 120 W HF)	2 x Class D 1440 W Peak (1200W LF + 240 W HF), 720 W Continuous (600 W LF + 120 W HF)	2 x Class D 1440 W Peak (1200W LF + 240 W HF), 720 W Continuous (600 W LF + 120 W HF)
<b>DSP Controls---D-EQ</b>				
	FLAT/MONITOR/BASS/PUNCH	FLAT/MONITOR/BASS/PUNCH	FLAT/MONITOR/BASS/PUNCH	FLAT/MONITOR/BASS/PUNCH
<b>Amplifier Protection</b>				
Power On & Thermal Protection	Yes	Yes	Yes	Yes
Low Line Voltage Shut Down	Yes	Yes	Yes	Yes
Drivers, DC, Short & Clip Protection	Yes	Yes	Yes	Yes
Limiter & Power Indicators	Yes	Yes	Yes	Yes
<b>Inputs and Outputs</b>				
Input A - type	Balanced / RCA	Balanced/RCA/Bluetooth (aptX,with TWS link)	Balanced	Balanced/Bluetooth (aptX,with TWS link)
Input Sensitivity	775 mV (0 dBu)	775 mV (0 dBu)	775 mV (0 dBu)	775 mV (0 dBu)
Maximum Input Level	4 V	4 V	4 V	4 V
Input Connectors	2 x XLR, 2 x 6.3 mm, 2 x RCA (Line/MIC)	2 x XLR, 2 x 6.3 mm, 2 x RCA (Line/MIC)	2 x XLR, 2 x 6.3 mm, 2 x RCA (Line/MIC)	2 x XLR, 2 x 6.3 mm, 2 x RCA (Line/MIC)
Input Impedance	20 K ohms	20 K ohms	20 K ohms	20 K ohms
Line Output Connector	XLR	XLR	XLR	XLR
Loop Gain	0 dB	0 dB	0 dB	0 dB
<b>AC Power Supply</b>				
	220-240 VAC / 100-120 VAC 50/60 Hz	220-240 VAC / 100-120 VAC 50/60 Hz	220-240 VAC / 100-120 VAC 50/60 Hz	220-240 VAC / 100-120 VAC 50/60 Hz
<b>Rigging / Bracket / Mounting Options</b>				
	8xM6 (1XM8 Back) inserts Pole-mount with lock screw Optional WPB-2 wall-mount bracket	8xM6 (1XM8 Back) inserts Pole-mount with lock screw Optional WPB-2 wall-mount bracket	9 x M8 inserts Pole-mount with lock screw Optional WPB-2 wall-mount bracket	9 x M8 threaded Pole-mount with lock screw Optional WPB-2 wall-mount bracket
Handles	4 (4 top 4 bottom)	4 (4 top 4 bottom)	4 (4 top 4 bottom)	4 (4 top 4 bottom)
Enclosure Material and finish	Injection Moulded Polypropylene	Injection Moulded Polypropylene	Injection Moulded Polypropylene	Injection Moulded Polypropylene
Colour Options	Black paint	Black paint	Black paint	Black paint
Grille Material & Finish	steel	steel	steel	steel
<b>Dimensions - Unpacked (mm / inches)</b>				
Height	433.6 mm / 17.1"	433.6 mm / 17.1"	558 mm / 22.0"	558 mm / 22.0"
Width Front	256 mm / 10.1"	256 mm / 10.1"	344 mm / 13.6"	344 mm / 13.6"
Width Rear	100.1 mm / 3.9"	100.1 mm / 3.9"	245 mm / 9.6"	245 mm / 9.6"
Depth	240 mm / 9.5"	240 mm / 9.5"	340 mm / 13.4"	340 mm / 13.4"
<b>Dimensions - Packed (mm / inches)</b>				
Height	509 mm / 20.0"	509 mm / 20.0"	645 mm / 25.4"	645 mm / 25.4"
Width Front	326 mm / 12.8"	326 mm / 12.8"	425 mm / 16.7"	425 mm / 16.7"
Width Rear	326 mm / 12.8"	326 mm / 12.8"	425 mm / 16.7"	425 mm / 16.7"
Depth	310 mm / 12.2"	310 mm / 12.2"	419 mm / 16.5"	419 mm / 16.5"
Net Weight (kg / lbs)	10.7 kg / 23.5 lbs	10.7 kg / 23.5 lbs	16.2 kg / 35.6 lbs	16.2 kg / 35.6 lbs
Gross Weight (kg / lbs)	12.7 kg / 27.9 lbs	12.7 kg / 27.9 lbs	18.9 kg / 41.6 lbs	18.9 kg / 41.6 lbs



# T-SUB-AX15B

EVERYONE LOVES BASS !!



Everyone loves BASS! That is exactly why we have created the T-Sub-AX15B - our all-new new 700 w Continuous, 1400 w Peak 15" active subwoofer.

The internal Class D amplifier delivers huge output power into the custom quad-layer 15" Wharfedale Pro LF driver to produce extreme subs and low end pressure into any system.

Built for big bass, the plywood constructed cabinet is rock solid and is protected in durable Rhino Rock paint.

You'll not only 'feel' the T-Sub-AX15B, but you will also see it! A new illuminated WP logo badge subtly glows and adds to the overall on-stage "power" of the new T-Sub.

T-Sub-AX15B is the perfect companion for a Typhon, a Titan or a Tourus Wharfedale Pro active loudspeaker.

**Hold on to your socks!**  
T-Sub-AX15B is going to blow them off!



**+75%**  
power over  
Titan Sub A15 MKII

**700 w Continuous** **1400 w PEAK**

- 700 w Continuous (1400 w peak)
- 3.0" voice coil - Quad layer driver
- Plywood construction
- Illuminated LED front logo badge
- Convection cooled Class D amplifier
- Adjustable low pass filter
- 35 mm pole socket & durable side handles

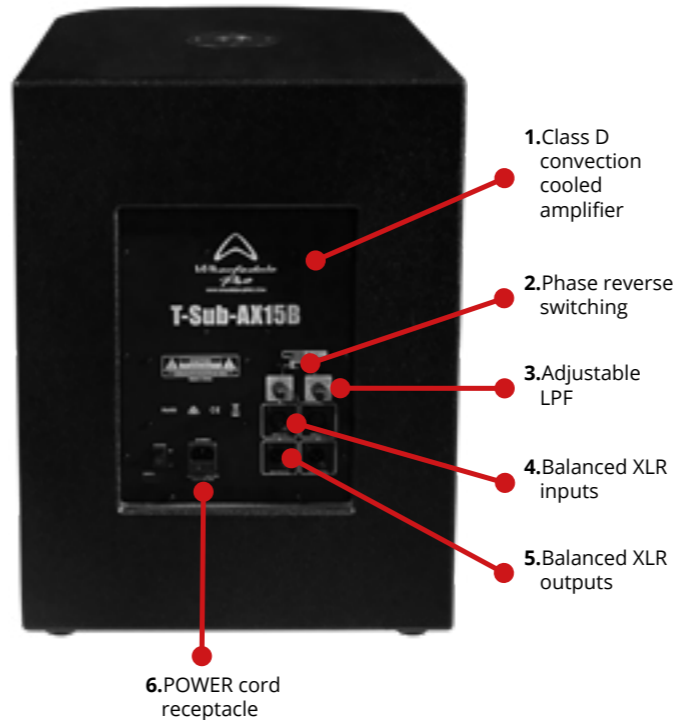
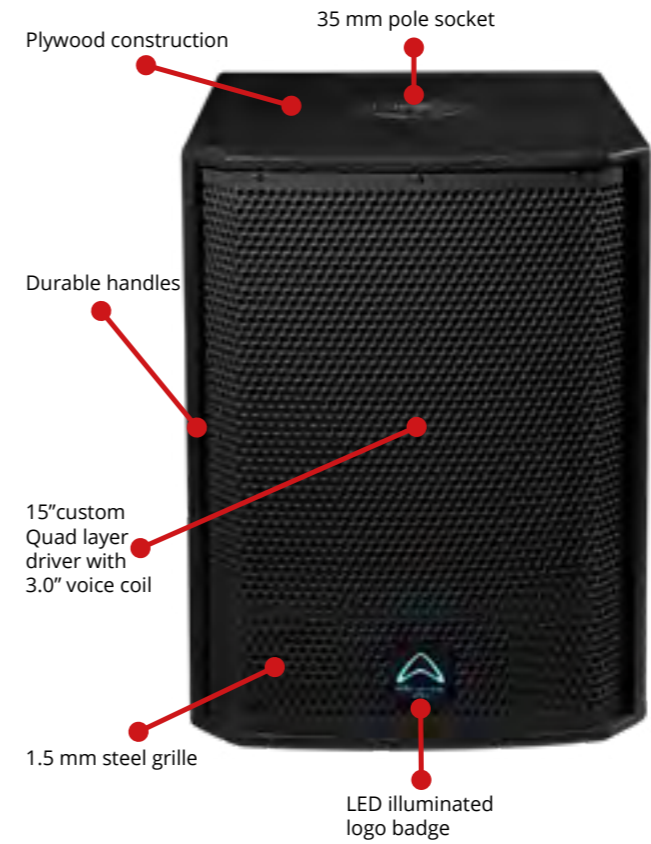

1. T-Sub-AX15B uses convection cooling. Although there is no internal fan, always ensure that when in use the surrounding area is clear from obstructions so that radiated heat can escape.
2. 0° to 180° phase reversal switch
3. Adjustable Low pass filter control 80-200 Hz. Adjust this to tune your subwoofer with your active top loudspeakers
4. Balanced XLR input connectors for connection from your input source.
5. Balanced XLR line output connectors for direct connection to active top loudspeakers.
6. POWER cord receptacle: This is a receptacle for a standard IEC, three prong, grounded AC electrical connection cord. Be sure that you are plugging into the correct source voltage that matches what is indicated just below the power cord jack.



<b>Model Name</b>	<b>T-Sub-AX15B</b>
System Type	Active 15" Subwoofer
Frequency Response (+/-3 dB)	45 Hz-200 Hz
Sensitivity @ 1w / 1 meter	97 dB
Maximum SPL (peak @ 1 meter)	129 dB
<b>Low Frequency Transducer</b>	
Size (mm / inches)	404 mm / 15"
Coil Size (mm / inches)	Quad layer 3.0"
Impedance	4 Ω
<b>Amplifier</b>	
Low-Frequency Power Amplifier (Class D)	700 w Continuous / 1400 w Peak
Crossover Frequency	LPF 80-200 Hz (adjustable)
<b>Controls</b>	
Amplifier Protection	Yes
Power On Protection	Power switch on / off mute
Thermal Protection	Amplifier shutdown, auto reset
Driver Protection	Yes
DC Protection	Yes
Short Protection	Yes
Limiter Indicator	Red LED
Input type	Balanced
Input Connector	Female XLR
Input Impedance	47 KΩ Balanced
Maximum Input Level	5 V
Input Sensitivity	-10 dB
Line Output Connector	Male XLR
Phase Switch Selection	0° / 180°
<b>AC Power details</b>	
Power Supply	SMPS
AC Power Options	100 V-120 V and 200 V-240 V
Power Indicator	Green(back) / Blue logo(front)
<b>Enclosure</b>	
Enclosure Material	15 mm Plywood
Colour	Black
Grille	1.5 mm steel
Pole Mount (Top)	35 mm
<b>Dimensions (Unpacked)(mm / inches)</b>	
Height	591 mm / 23.27"
Width	454 mm / 17.9"
Depth	523.9 mm / 20.63"
<b>Dimensions (packed)(mm / inches)</b>	
Height	689 mm / 27.1"
Width	544 mm / 21.4"
Depth	610 mm / 24.0"
<b>Weight</b>	
Net Weight (kg / lbs)	25.7 kg / 56.5 lbs
Gross Weight (kg / lbs)	29.5 kg / 64.9 lbs



# DVP-AX Series

POWERED AND ROAD-READY!



DVP-AX is a comprehensive new lineup of versatile and road-ready active loudspeakers. Class D amplification housed in ultra hard wearing cabinets make DVP-AX a perfect choice for hardworking DJ's and musicians on the road.

The full-range models feature advanced DSP processing with 6 presets tailored to overcome many real-life sonic challenges and a practical 2 channel mic/line mixer makes life on stage easier.

The floor monitor models feature a 7-band EQ to help deliver maximum volume without feedback and a handy slave output for connecting to passive floor monitors.

While the electronics of DVP-AX set them apart from the competition, it is important not to overlook the custom Wharfedale Pro drivers in this lineup. Using dual layer LF transducers and the acclaimed IRIS compression drivers, the mechanical features of DVP-AX have not been compromised.

DVP-AX delivers advanced electronics in a user-friendly format - but in a road-ready cabinet.



I Increased  
R Radius  
I Increased  
S Sensitivity



**FULL RANGE MODELS**  
DVP-AX12 / DVP-AX15 / DVP-AX215

**SUBWOOFERS**  
DVP-AX15B / DVP-AX18B

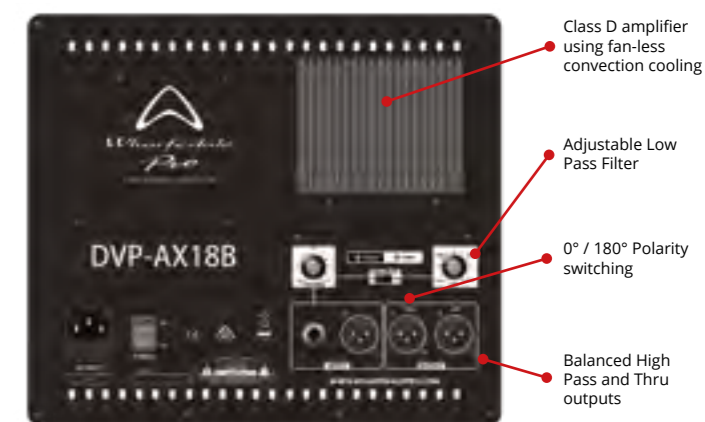

**MONITORS**  
DVP-AX12M / DVP-AX15M

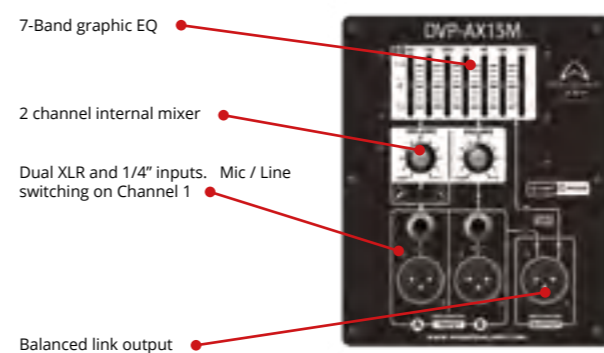

- Advanced DSP system on full range models
- Efficient, convection cooled, Class D amplification
- 90° x 60° elliptical waveguides
- Dual layer LF transducers

- Monitors feature 7-band EQ and Slave output
- Subwoofers feature adjustable LPF
- Solid MDF construction with Rhino Rock finish
- Powerful, practical and road-ready

## SPECIFICATIONS



Model Name	DVP-AX12	DVP-AX12M	DVP-AX15	DVP-AX15M
System Type	Active 12" 2-way	Active 12" 2-way monitor	Active 15" 2-way	Active 15" 2-way monitor
Frequency Response (+/-3 dB)	60-18 kHz	60-18 kHz	50-18 kHz	55-18 kHz
Frequency Range (-10 dB)	55-20 kHz	55-20 kHz	45-20 kHz	50-20 kHz
Maximum SPL @1 m	129 dB	129 dB	130 dB	130 dB
Sensitivity @ 1 W / 1 m	98 dB	98 dB	98 dB	98 dB
LF transducer Size (mm / inches)	305 mm / 12"	305 mm / 12"	381 mm / 15"	381 mm / 15"
LF Coil Size (mm / inches)	Dual layer 2.5"	Dual layer 2.5"	Dual 2 layer 2.5"	Dual 2 layer 2.5"
HF transducer : Type	Compression Driver	Compression Driver	Compression Driver	Compression Driver
HF Coil Size (mm / inches)	44 mm / 1.75"	44 mm / 1.75"	44 mm / 1.75"	44 mm / 1.75"
HF Exit Size (mm / inches)	25 mm / 1"	25 mm / 1"	25 mm / 1"	25 mm / 1"
HF Diaphragm Material	Titanium	Titanium	Titanium	Titanium
Nominal Coverage (H x V)	90° x 60°	90° x 60°	90° x 60°	90° x 60°
LF Power Amplifier -Class D, RMS/Peak Watts	150 W / 300 W	250 W / 500 W (8 Ω) 500 W / 1000 W (4 Ω)	350 W / 700 W	250 W / 500 W (8 Ω) 500 W / 1000 W (4 Ω)
HF Power Amplifier -Class D, RMS/Peak Watts	50 W / 100 W	N/A	50 W / 100 W	N/A
DSP	Yes	7-band EQ	Yes	7-band EQ
Controls--D-EQ	1:FLAT 2:MONITOR 3:SPEECH 4:BASS 5:PUNCH 6:LIVE	60 Hz 120 Hz 480 Hz 1 kHz 4 kHz 8 kHz 16 kHz	1:FLAT 2:MONITOR 3:SPEECH 4:BASS 5:PUNCH 6:LIVE	60 Hz 120 Hz 480 Hz 1 kHz 4 kHz 8 kHz 16 kHz
Amplifier Protection. Power On, Thermal, low voltage	Yes	Yes	Yes	Yes
Driver Protection,DC, Short, Clip indicator	Yes	Yes	Yes	Yes
Limiter Indicator	Red LED	Red LED	Red LED	Red LED
Power Indicator	Green LED (Red LED front)	Green LED (Red LED front)	Green LED (Red LED front)	Green LED (Red LED front)
INPUTS : Input Sensitivity : Balanced	775 mv	775 mv	775 mv	775 mv
Maximum Input Level	4 v	6 v	4 v	6 v
Input Connector	2*XLR & 2*1/4" (Line/MIC)	2*XLR & 2*1/4" (Line/MIC)	2*XLR & 2*1/4" (Line/MIC)	2*XLR & 2*1/4" (Line/MIC)
Input Impedance	Balanced:20 K	Balanced:20 K	Balanced:20 K	Balanced:20 K
LPF control	N/A	N/A	N/A	N/A
Polarity Control	N/A	N/A	N/A	N/A
OUTPUTS : Line Output Connector	XLR	XLR(Balanced out)	XLR	XLR(Balanced out)
AC Power Options : SMPS	220-240 V 50/60 Hz 100-120 V 50/60 Hz	220-240 V 50/60 Hz 100-120 V 50/60 Hz	220-240 V 50/60 Hz 100-120 V 50/60 Hz	220-240 V 50/60 Hz 100-120 V 50/60 Hz
Pole socket	Dual-angle (0°/10°) 35 mm socket	N/A	Dual-angle (0°/10°) 35 mm socket	N/A
Handles	2 carry handles (one on each side)	2 carry handles (one on each side)	2 carry handles (one on each side)	2 carry handles (one on each side)
Enclosure Material and Finish	MDF / Black paint	MDF / Black paint	MDF / Black paint	MDF / Black paint
Grille Material & Finish	steel	steel	steel	steel
Dimensions - Unpacked (mm / inches); Height	617 mm / 24.3"	428 mm / 16.9"(SITU)	689 mm / 27.1"	520 mm / 20.5"(SITU)
Width	361.2 mm / 14.2"	359 mm / 14.1"	443.5 mm / 17.5"	449 mm / 17.7"
Width (rear)	207.6 mm / 8.2"	359 mm / 14.1"	243.5 mm / 9.6"	449 mm / 17.7"
Depth	342.4 mm / 13.5"	537 mm / 21.1"	429.0 mm / 16.9"	640 mm / 25.2"
Dimensions - Packed (mm / inches);Height	680 mm / 26.8"	396 mm / 15.6"	750 mm / 29.5"	485 mm / 19.1"
Width	438 mm / 17.3"	396 mm / 15.6"	520 mm / 20.5"	676 mm / 26.6"
Width (rear)	236 mm / 9.3"	573 mm / 22.6"	290 mm / 11.4"	676 mm / 26.6"
Depth	428 mm / 16.9"	448 mm / 17.6"	485 mm / 19.1"	541 mm / 21.3"
Net Weight (kg / lbs)	18.7 kg / 41.1 lbs	18.5 kg / 40.7 lbs	23.8 kg / 52.4 lbs	23.5 kg / 51.7 lbs
Gross Weight (kg / lbs)	21.4 kg / 47.1 lbs	21.4 kg / 47.1 lbs	27.3 kg / 60.1 lbs	27.2 kg / 59.8 lbs

## SPECIFICATIONS



Model Name	DVP-AX215	DVP-AX15B	DVP-AX18B
System Type	Active 2 x 15" 2-way	Active 15" subwoofer	Active 18" subwoofer
Frequency Response (+/-3 dB)	45-18 kHz	45-150 Hz	35-150 Hz
Frequency Range (-10 dB)	40-20 kHz	38-150 Hz	30-150 Hz
Maximum SPL @1 m	135 dB	130 dB	132 dB
Sensitivity @ 1 W / 1 m	101dB	98 dB	99 dB
LF transducer Size (mm / inches)	2 * 381 mm / 15"	381 mm / 15"	470 mm / 18"
LF Coil Size (mm / inches)	Dual 2 layer 2.5"	Dual layer 2.5"	Quad layer 2.5"
HF transducer : Type	Compression Driver	-	-
HF Coil Size (mm / inches)	44 mm / 1.75"	-	-
HF Exit Size (mm / inches)	25 mm / 1"	-	-
HF Diaphragm Material	Titanium	-	-
Nominal Coverage (H x V)	90° x 60°	-	-
LF Power Amplifier -Class D, RMS/Peak Watts	500 W / 1000 W	600 W / 1200 W	600 W / 1200 W
HF Power Amplifier -Class D, RMS/Peak Watts	70 W / 140 W	-	-
DSP	Yes	N/A	N/A
Controls--D-EQ	1:FLAT 2:MONITOR 3:SPEECH 4:BASS 5:PUNCH 6:LIVE	N/A	N/A
Amplifier Protection. Power On, Thermal, low voltage	Yes	Yes	Yes
Driver Protection,DC, Short, Clip indicator	Yes	Yes	Yes
Limiter Indicator	Red LED	Red LED	Red LED
Power Indicator	Green LED (Red LED front)	Green LED (Red LED front)	Green LED (Red LED front)
INPUTS : Input Sensitivity : Balanced	775 mv	775 mv	775 mv
Maximum Input Level	4 v	6 v	6 v
Input Connector	2*XLR & 2*1/4" (Line/MIC)	XLR & 1/4" (Line/MIC)	XLR & 1/4" (Line/MIC)
Input Impedance	Balanced:20 K	Balanced:20 K	Balanced:20 K
LPF control	N/A	80 Hz-120 Hz	80 Hz-120 Hz
Polarity Control	N/A	0°/180°	0°/180°
OUTPUTS : Line Output Connector	XLR	XLR THRU/HPF(OUT)	XLR THRU/HPF(OUT)
AC Power Options : SMPS	220-240 V 50/60 Hz 100-120 V 50/60 Hz	220-240 V 50/60 Hz 100-120 V 50/60 Hz	220-240 V 50/60 Hz 100-120 V 50/60 Hz
Pole socket	N/A	35 mm pole socket	35 mm pole socket
Handles	2 carry handles (one on each side)	2 carry handles (one on each side)	2 carry handles (one on each side)
Enclosure Material and Finish	MDF / Black paint	MDF / Black paint	MDF / Black paint
Grille Material & Finish	steel	steel	steel
Dimensions - Unpacked (mm / inches); Height	1058 mm / 41.7"	591 mm / 23.3"	650 mm / 25.6"
Width	444.5 mm / 17.5"	454 mm / 17.9"	528 mm / 20.8"
Width (rear)	245.3 mm / 9.7"	454 mm / 17.9"	528 mm / 20.8"
Depth	429.0 mm / 16.9"	534 mm / 21.0"	639 mm / 25.2"
Dimensions - Packed (mm / inches);Height	1125 mm / 44.3"	681 mm / 26.8"	740 mm / 29.1"
Width	520 mm / 20.5"	620 mm / 24.4"	725 mm / 28.5"
Width (rear)	290 mm / 11.4"	620 mm / 24.4"	725 mm / 28.5"
Depth	496 mm / 19.5"	540 mm / 21.3"	614 mm / 24.2"
Net Weight (kg / lbs)	34.3 kg / 75.5 lbs	29.9 kg / 65.8 lbs	38.3 kg / 84.3 lbs
Gross Weight (kg / lbs)	38.7 kg / 85.1 lbs	34.9 kg / 76.8 lbs	44.2 kg / 97.2 lbs



# EVP-XPM

## DEDICATED FLOOR MONITORS



### Keep it tidy

EVP-XPM active floor monitors have been specifically designed to give maximum versatility on stage. These are not just active monitors turned sideways but are built specifically as floor monitors. The inclusion internal amplification, a 5-band graphic EQ and well thought out connectors, reduces unnecessary cabling and additional hardware on stage. The balanced input uses a combi XLR/jack connector so it's easy to always find suitable connection cables.

### Power out

EVP-XPM's also feature a unique powered 'Speaker output' jack. This allows for connection to a passive slave monitor (such as the EVP-X15M MKII) without the need for additional amplification or complex cabling. One active EVP-XPM can also drive your second passive floor monitor.

### Protection

Externally the EVP-XPMs are protected by a durable carpet finish. Internally the Dynamic / AGC protection circuitry provides extreme protection at both the driver and the amplifier stage so the EVP-XPM can be played at maximum levels over long periods without fear of system failure. The Green LED on the front of the EVP-XPM illuminates when the AGC is activated, similar to the orange LED on the front of the amplifier.

Model Name	EVP-X12PM	EVP-X15PM
Configuration	2-way Bi-Amplified	2-way Bi-Amplified
High Frequency Transducer	1.75" Titanium Compression Driver	1.75" Titanium Compression Driver
Low Frequency Transducer	12"	15"
Frequency Response	50 Hz - 20 kHz	50 Hz - 20 kHz
Power (RMS/Peak)	300 W / 500 W	300 W / 500 W
EQ	5-Band	5-Band
Enclosure Finish	Black Carpet	Black Carpet
Input	1 x XLR Jack / Combi	1 x XLR Jack / Combi
Output	1 x XLR, 1 x 6.3 mm Jack (Powered output)	1 x XLR, 1 x 6.3 mm Jack (Powered output)
Protection	Dynamic / AGC protection circuitry	Dynamic / AGC protection circuitry
Dimensions (H x W x D)	560 mm X 424 mm X 441 mm	675 mm X 445 mm X 473.5 mm
Net Weight	22.5 kg	27.4 kg

# ISOLINE

## POWERFUL, YET DISCREET COLUMN FORMATION PA SYSTEMS WITH BLUETOOTH

- Bluetooth
- Lightweight
- 3" Full Range Drivers
- Designed for live Performance
- Built-in Mixer
- Durable, Painted Speaker Cabinet

Isoline is the fastest route to a professional, compact PA system. Made up of a column formation loudspeaker interconnected with a high powered subwoofer with its own built-in amplifier, Isoline delivers a full-range sound from a system that is easily packed down into a car boot with ease. For ultimate convenience Isoline comes complete with a built-in mixer and wireless Bluetooth input.

### MORE CONNECTIONS, LESS GEAR

Isolines' built-in mixer gives complete control over the 2 x XLR / Jack combi inputs (with mic and line level) plus the phono inputs - Perfect for mixing backing tracks, live vocals and instruments. The Bluetooth input is also easily paired with any mobile device in seconds. This gives users an intuitive interface between a tablet or mobile device and the PA system. Either way - Isoline delivers convenience.

There are even padded optional tour bags available. See the last page of this Product Catalogue.

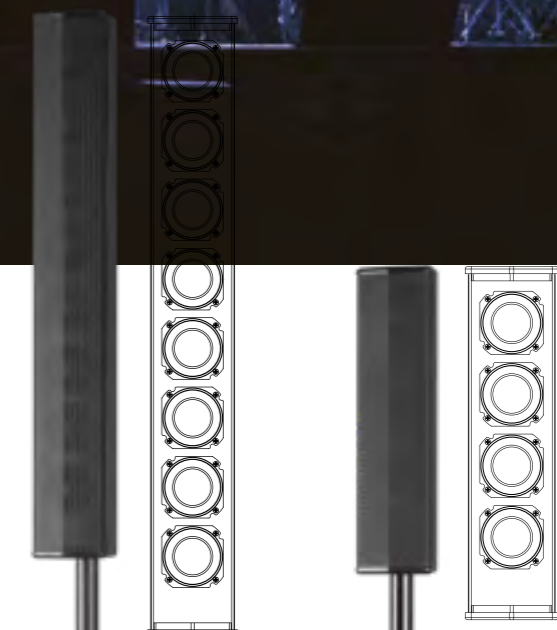

### ISOLINE 812

- 500 W RMS / 800 W Peak
- 40 Hz - 20 kHz Frequency Response
- 8 x 3" High / Mid Drivers
- 12" long throw subwoofer

### ISOLINE 410

- 380 W RMS / 650 W Peak
- 50 Hz - 20 kHz Response
- 4 x 3" High / Mid Drivers
- 10" long throw subwoofer

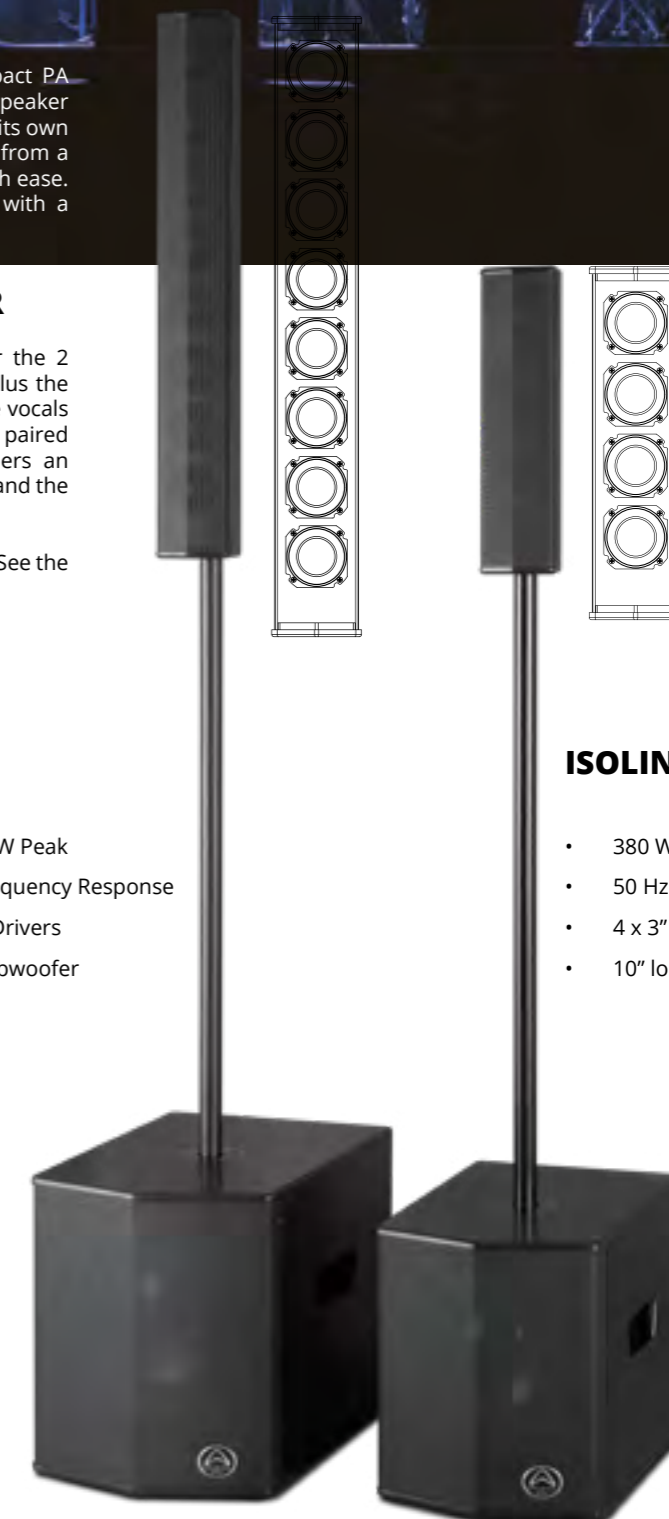



# EZ-12A / EZ-15A

EXTREMELY PORTABLE PA . WHERE WILL YOU GO WITH YOURS?



EZ-15A

EZ-12A

## EZ-A models

- Battery powered and extremely portable
- USB/TF card MP3 player
- Bluetooth input and IR Remote control
- Includes 2 wireless handheld microphones
- Internal Echo processor
- Pull up trolley handle
- 2 integral handles
- User-friendly rear panel controls
- EZ-15A : 118 dB Max SPL @ 1 meter
- EZ-12A : 115 dB Max SPL @ 1 meter
- 100 v - 240 v AC input



Includes two wireless handheld mics and an IR remote control

## Active PA Speakers



Extendable handle

MP3 player via USB and TF card

5-Band graphic EQ

Input for optional wired mic or optional wireless headset mic system

Ducking control

Rechargeable battery

Durable wheels

## SPECIFICATIONS

Model Name	EZ-12A	EZ-15A
System Type	Active portable PA	Active portable PA
Frequency range	65 Hz - 18 kHz	55 Hz - 18 kHz
Impedance	4 Ω	4 Ω
LF Transducer size	12"	15"
LF Transducer voice coil	38 mm / 1.5"	38 mm / 1.5"
HF Transducer	1"	1"
Dispersion (H x V)	90° x 50°	90° x 50°
Max SPL	115 dB	118 dB
Mic input	XLR and 1/4" jack	XLR and 1/4" jack
Line input	L/R RCA connector	L/R RCA connector
Line output	L/R RCA connector	L/R RCA connector
5-Band graphic EQ	63 Hz / 80 Hz / 480 Hz / 3 kHz / 10 kHz +/-12 dB	63 Hz / 80 Hz / 480 Hz / 3 kHz / 10 kHz +/-12 dB
Rx : Wireless mic	2 models available (600 - 606 MHz or 863 - 865 MHz)	2 models available (600 - 606 MHz or 863 - 865 MHz)
Wireless handheld microphones	2 pcs included	2 pcs included
Wireless microphone range	40 m (theoretical value)	40 m (theoretical value)
Echo	Yes	Yes
MP3 player	Yes (USB/TF)	Yes (USB/TF)
Bluetooth range	10 m	10 m
Power (Peak)	100 w	140 w
Battery power	Up to 5 hours. (6 hours charge time)	Up to 5 hours. (6 hours charge time)
Amp THD	0.1% 20 Hz-20 kHz	0.1% 20 Hz-20 kHz
Amp frequency response	20 Hz - 20 kHz +/-1 dB	20 Hz - 20 kHz +/-1 dB
Input voltage	100 v-240 v 50 Hz / 60 Hz	100 v-240 v 50 Hz / 60 Hz
Dimensions	420 x 350 x 640 mm	490 x 400 x 740 mm
Net weight	10.5 kg	13.7 kg
Gross weight	12.5 kg	15.8 kg



# DELTA-AX

## OUR FLAGSHIP DELTA-X SERIES - AMPLIFIED AND REFINED



2" Titanium Compression HF



Active Models



Low Distortion, Maximum Efficiency



Ready for Rigging



Performance you can depend on



Rhino Rock Paint

Specifically designed as a multi-purpose solution the new DELTA-AX provides high-end active sound reinforcement for touring applications and professional musicians.



DELTA-AX12

DELTA-AX15

DELTA-AX15B

DELTA-AX18B

### Bi-Amplification with DSP

Capable of producing extraordinary levels of SPL and output, inside every DELTA-AX speaker is a high headroom amplifier exclusively engineered by Wharfedale Pro. The 2 way 12" and 15" models also feature an integrated 2 channel mixer with onboard Qubit DSP insuring smoother and more controlled sonic performance.

### Ready for a life time on the road

DELTA-AX is constructed from birch plywood and features dual angle pole mounts to ensure that your sound is aimed directly at the audience, not at the ceiling.

### ....and ready for installation

Multiple rigging points and durable construction also make DELTA-AX a great installation solution. Clubs, restaurants and houses of worship around the world already rely on DELTA systems day in, day out.

### Evolutionary refinement

The new DELTA-AX series features improved internal electronics. Newly designed power components ensure high performance and extreme reliability.

DELTA-AX can easily be recognised with the iconic Wharfedale Pro boomerang logo routed into the top surface.

### Connectivity and control



DELTA-AX12 / DELTA-AX15 rear panel



DELTA-AX15B / DELTA-AX18B rear panel



### DELTA-AX12 / DELTA-AX15

- 2-way Bi-Amplified speaker system
- Low frequency power amplifier 650 W RMS, 1300 W peak (CLASS D)
- High frequency power amplifier 100 W RMS, 200 W peak (CLASS D)
- 56-bit, 192 kHz DSP processing
- Independent LF and HF signal limiting
- Thermal, DC and short circuit fault protections
- Bass / Treble EQ controls
- Switchable 90 Hz monitor filter

- Combo XLR/1/4" jack balanced line or mic inputs
- Female XLR balanced line level output
- Rear panel mic/line level switch
- Rear panel front LED defeat switch
- Remote volume control (applied voltage controlled)
- 90° x 45° elliptical Wave Guide (EWG)
- Dual-angle (0° or 10°) 35 mm pole socket
- Suspension points 6 x M10 threaded
- Black rhino paint finish with boomerang logo
- 15 mm plywood construction

### DELTA-AX15B





- 15" Active subwoofer
- Low frequency power amplifier 900 W RMS, 1800 W peak
- 130 dB Max SPL
- High headroom class D amplifier
- 42-200 Hz frequency response
- 15" woofer with 4" voice coil
- Adjustable crossover: 80 Hz - 200 Hz
- 100 Hz high pass filter output
- Integral phase switch 0° and 180°

### DELTA-AX18B

- 18" Active subwoofer
- Low frequency power amplifier 1000 W RMS, 2000 W peak
- 132 dB Max SPL
- High headroom class D amplifier
- 38-200 Hz frequency response
- 18" woofer with 4" voice coil
- Adjustable crossover: 80 Hz - 200 Hz
- 100 Hz high pass filter output
- Integral phase switch 0° and 180°



## SPECIFICATIONS

				
Model Name	DELTA-AX12	DELTA-AX15	DELTA-AX15B	DELTA-AX18B
System Type	Active 12" 2-way Bi-Amplified	Active 15" 2-way Bi-Amplified	Active 15" Subwoofer	Active 18" Subwoofer
Frequency Response (+/-3 dB)	60 Hz - 20 kHz	50 Hz - 20 kHz	42 Hz - 200 Hz	38 Hz - 200 Hz
Frequency Range (-10 dB)	55 Hz - 20 kHz	45 Hz - 20 kHz		
Calculated Maximum SPL @1 m	130 dB	131 dB	130 dB	132 dB
<b>Low Frequency Transducer - Size (mm / inches)</b>	332 mm / 12"	404 mm / 15"	404 mm / 15"	470 mm / 18"
Coil Size (mm / inches)	75 mm / 3"	75 mm / 3"	101.6 mm / 4"	101.6 mm / 4"
Impedance	4 Ω	4 Ω	8 Ω	8 Ω
<b>High Frequency Transducer - Type</b>	Compression Driver	Compression Driver	-	-
Coil Size (mm / inches)	51.2 mm / 2"	51.2 mm / 2"	-	-
Exit Size (mm / inches)	35.6 mm / 1.4"	25 mm / 1"	-	-
Diaphragm Material	Titanium	Titanium	-	-
Impedance	8 Ω	8 Ω	-	-
Nominal Coverage (H x V)	90° x 45°	90° x 45°	-	-
<b>Amplifiers</b>				
Low-Frequency Power Amplifier RMS	600 w (Class D)	600 w (Class D)	900 w (Class D)	1000 w (Class D)
High-Frequency Power Amplifier RMS	100 w (Class D)	100 w (Class D)	NA	NA
Amplifier Protection	Yes	Yes	Yes	Yes
Power On Protection	Power switch on/off mute	Power switch on/off mute	Power switch on/off mute	Power switch on/off mute
Thermal Protection	Amplifier Shut Down, Auto Reset	Amplifier Shut Down, Auto Reset	Amplifier Shut Down, Auto Reset	Amplifier Shut Down, Auto Reset
Low Line Voltage Shut Down	80% Nominal Line Voltage	80% Nominal Line Voltage	80% Nominal Line Voltage	80% Nominal Line Voltage
Driver Protection	Independent LF and HF Limiters	Independent LF and HF Limiters	Yes	Yes
DC and Short Protection	Yes	Yes	Yes	Yes
Clip Limiter	Turns on Appro x 650 w Output	Turns on Appro x 650 w Output	Turns on Appro x 900 w Output	Turns on Appro x 1000 w Output
Limiter Indicator	Red LED	Red LED	Red LED	Red LED
Power Indicator	Green LED	Green LED	Green LED	Green LED
<b>Connectors</b>				
Input A - type	Switchable Balanced Mic or Line Level Input	Switchable Balanced Mic or Line Level Input	Balanced	Balanced
Input Sensitivity	Mic:-40 dBu Line:0 dBu	Mic:-40 dBu Line:0 dBu	Line:0 dBu	Line:0 dBu
Maximum Input Level	22 dBu	22 dBu	22 dBu	22 dBu
Input Connector	XLR 1/4" Combo jack / 2 x RCA	XLR 1/4" Combo jack / 2 x RCA	TRS jack and Female XLR	TRS jack and Female XLR
Input Impedance	Balanced:20 KΩ Unbalanced:10 KΩ	Balanced:20 KΩ Unbalanced:10 KΩ	Balanced:20 KΩ Unbalanced:10 KΩ	Balanced:20 KΩ Unbalanced:10 KΩ
Line Output Connector	Switchable LOOP/MIX Balanced Male XLR Connector	Switchable LOOP/MIX Balanced Male XLR Connector	Male XLR Connector	Male XLR Connector
Impedance Balanced	Balanced: 200 Ω Unbalanced:100 Ω	Balanced: 200 Ω Unbalanced:100 Ω	Balanced: 200 Ω Unbalanced:100 Ω	Balanced: 200 Ω Unbalanced:100 Ω
Loop Gain	0 dB	0 dB	0 dB	0 dB
<b>AC Power details - Power Supply</b>	High Efficiency SMPS	High Efficiency SMPS	High Efficiency SMPS	High Efficiency SMPS
AC Power Options	AC100-120 V~ / 220-240 V~,50/60 HZ	AC100-120 V~ / 220-240 V~,50/60 HZ	AC100-120 V~ / 220-240 V~,50/60 HZ	AC100-120 V~ / 220-240 V~,50/60 HZ
Power On Indicator	Green LED	Green LED	Green LED	Green LED
Hardware - Rigging	M10 x 6	M10 x 6		
Enclosure Material and finish	15 mm Plywood	15 mm Plywood	15 mm Plywood	15 mm Plywood
Colour Options	Black Rhino Paint	Black Rhino Paint	Black Rhino Paint	Black Rhino Paint
Grille Material & Finish	1.2 Steel	1.2 Steel		
<b>Unpacked dimensions - Height</b>	640 mm / 25.2"	700 mm / 27.56"	471 mm / 18.54"	539 mm / 21.22"
Width (Front)	390 mm / 15.35"	446 mm / 17.56"	471 mm / 18.54"	539 mm / 21.22"
Width (Back)	241.2 mm / 9.5"	281.4 mm / 11.08"	471 mm / 18.54"	539 mm / 21.22"
Depth	373 mm / 14.69"	406 mm / 15.98"	600 mm / 23.62"	650 mm / 25.59"
<b>Packed Dimensions - Height</b>	745 mm / 29.3"	803 mm / 31.6"	556 mm / 21.89"	624 mm / 24.57"
Width (Front)	566 mm / 22.3"	638 mm / 25.1"	672 mm / 26.46"	722 mm / 28.43"
Width (Back)	328 mm / 12.9"	366 mm / 14.4"	672 mm / 26.46"	722 mm / 28.43"
Depth	464 mm / 18.3"	498 mm / 19.6"	543 mm / 21.38"	611 mm / 24.06"
Net Weight (kg / lbs)	27.9 kg / 61.2 lbs	33 kg / 72.6 lbs	33.1 kg / 72.82 lbs	38.4 kg / 84.48 lbs
Gross Weight (kg / lbs)	32.5 kg / 71.5 lbs	38.5 kg / 84.7 lbs	36.7 kg / 80.74 lbs	44.3 kg / 97.46 lbs

## Passive PA Speakers

# TITAN 8

## VERSATILE AND LIGHTWEIGHT - DURABLE FOR INDOORS AND OUT



Lightweight



Moisture Rejection



Ready for Rigging



Designed for live Performance



90° x 60° elliptical waveguide



Black and white versions

The Titan 8 passive speaker combines the Titan technology, materials and design philosophy and includes a heavy-duty cast-frame woofer. This ensures absolute accuracy, high output and the smooth, wide dispersion of the critical mid and high frequency ranges.

Titan 8 is ultra-compact and lightweight so lends itself to a whole host of audio applications from gym installations, DJ booth monitors and public address.



Optional WPB-T8 mounting kit



TITAN 8



- 150 W RMS / 300 W Program / 600 W Peak
- 124 dB Max SPL
- 70 Hz - 20 kHz frequency response
- Custom 8" Heavy duty moisture-proof LF driver
- Proprietary 90° x 60° Elliptical Wave Guide Horn design
- High-end Titanium HF Compression Driver
- Sophisticated Linkwitz-Riley 24 dB/octave crossover design
- Tough, yet lightweight Polypropylene molded cabinet with rubber padded handles
- Multiple M6, M8 & M10 rigging points and integral tripod stand adapter
- Trapezoid shape for arrays as well as stage monitor applications
- Titan Tourbags available
- Both 1/4" and NL4 connectors provided
- Available in Black, White or Grey

TITAN 8 White





# TITAN-X

VERSATILE AND LIGHTWEIGHT - DURABLE FOR INDOORS AND OUT



Titanium Compression Driver



Lightweight



Moisture Rejection



Ready for Rigging



100° x 80° Hybrid Symmetry horn



Black and white versions

# TITAN-Z

THE MOST POWERFUL TITANS



Titanium Compression Driver



Lightweight



Moisture Rejection



Ready for Rigging



100° x 80° Hybrid Symmetry horn



Performance you can depend on



## Our versatile passive Titans

The Titan-X12 and X15 now feature all-new HF and LF drivers. The IRIS X4 HF compression driver has been completely re-evaluated for both coverage and sound quality ensuring a much smoother sound, especially at high output.

The all-new LF driver has improved moisture rejection characteristics which allows TITAN-X to be installed into hostile environments.

We have also tweaked the laminar rib cabinet structure to improve structural strength for durability and acoustic performance. TITAN-X raises the bar for portable PA and is built to last.

- HF Drivers have been honed acoustically for HF-frequency detail and power
- LF Drivers reject moisture for resistance in all environments
- Proprietary 100° x 80° Hybrid Symmetry Horn design
- Tough, yet lightweight Dynamic Polypropylene cabinet with rubber padded handles
- 10 x M8 rigging points and integral tripod stand adapter
- Rugged protective grille and top-stacking receptacles
- Trapezoid design for arrays as well as stage monitor applications
- Available in black or white



## INDOOR AND OUTDOOR INSTALLATION

Both Titan-Z and Titan-X feature moisture proof woofers which can withstand outdoor and extreme conditions. Additional protection can be found with the optional Titan Tourbags. These custom made speaker bags have an unzippable front panel for maximum protection.



**Titan-12Z**  
2000 w Peak



**Titan-15Z**  
2800 w Peak



## The highest power handling Titans - EVER !

Do not be deceived by familiar looks. The new Titan Z's may appear cosmetically to be the same as our TITAN-X - but, it is what is inside that matters.

Titan-12Z and 15Z feature extreme power handling transducers with high electrical sensitivity. This results in unimaginable power handling specifications and remarkable SPL. Custom built Wharfedale Pro drivers are what makes this possible.

The new 15Z features an enormous 4" LF voice coil for breath-taking power handling capabilities along with an enhanced compression driver with a 2" coil. Meanwhile the smaller 12Z features a category leading 3" LF voice coil and our acclaimed IRIS X compression driver with its 1.75" voice coil.

- Extended-range, super sensitive Titanium dome HF drivers
- New 2" voice coil HF compression driver (15Z)
- Titan 12Z - 132 dB Max SPL - 2000 watts peak
- Titan 15Z - 133.5 dB Max SPL - 2800 watts peak
- Massive voice coils for improved heat dissipation and power handling
- Compatible with all Titan mounting hardware.





Model Name	TITAN 8	Titan-X12	Titan-X15
System Type	Passive	Passive	Passive
Configuration	8" 2-way	12" 2-way	15" 2-way
Frequency Response (+/-3 dB)	70 - 20 kHz	55 Hz-20 kHz	50 Hz-20 kHz
Frequency Range (-10 dB)	65 - 20 kHz	50 Hz-20 kHz	40 Hz-20 kHz
Sensitivity (2.83 v / 1 m)	96 dB	98 dB	97 dB
Calculated Maximum SPL @1 m	124 dB	128 dB	129 dB
System Rated Impedance	8 Ω	8 Ω	8 Ω
<b>Low Frequency Transducer</b>			
Size	203 mm / 8"	305 mm / 12"	381 mm / 15"
Voice Coil Size	38.86 mm / 1.53"	64.26 mm / 2.5"	75 mm / 3.0"
Rated Impedance	8 Ω	8 Ω	8 Ω
LF Power (re:AES2-2012)	150 w	250 w	400 w
<b>High Frequency Transducer</b>			
HF Driver Type	Compression Driver	Compression Driver	Compression Driver
Voice Coil Size	25 mm / 1"	44 mm / 1.75"	44 mm / 1.75"
Exit Size	30 mm / 1.2"	25 mm / 1"	25 mm / 1"
Diaphragm Material	Mylar	Titanium	Titanium
Rated Impedance	8 Ω	8 Ω	8 Ω
HF Power (re:AES2-2012)	20 w	40 w	40 w
Nominal Coverage (H x V)	Elliptical waveguide 90° x 60°	Hybrid Symmetry Horn 100°x80°	Hybrid Symmetry Horn 100°x80°
<b>Power</b>			
System Continuous Power	150 w	250 w	400 w
System Programme Power	300 w	500 w	800 w
System Peak Power	600 w	1000 w	1600 w
Crossover frequency	2-way 2.4 kHz / Linkwitz-Riley	2.6 kHz	2.7 kHz
Input Connector	2 x NL4 (speakON compatible) 2 x 1/4" Jack	2 x NL4 (speakON compatible)	2 x NL4 (speakON compatible)
<b>Hardware</b>			
Pole Mount	35 mm with lock screw	35 mm with lock screw	35 mm with lock screw
Handles	1 on side	2 on sides	2 on sides
Mounting points	M6 * 8	M8 * 10	M8 * 10
<b>Enclosure</b>			
Enclosure Material	Trapezoidal / Polypropylene	Trapezoidal / Polypropylene	Trapezoidal / Polypropylene
Finish	Grey, Black, White	Black / white	Black / white
Grille Material & Finish	1.2 steel	1.2 steel	1.2 steel
<b>Dimensions - Unpacked</b>			
Height	396 mm / 15.59"	582.7 mm / 22.9"	728.5 mm / 28.7"
Width Front	266 mm / 10.47"	384.6 mm / 15.1"	480.6 mm / 18.9"
Width Rear	266 mm / 10.47"	384.6 mm / 15.1"	480.6 mm / 18.9"
Depth	221 mm / 8.7"	318.6 mm / 12.5"	395.6 mm / 15.6"
<b>Dimensions - Packed</b>			
Height	463 mm / 18.2"	663 mm / 26.1"	830 mm / 32.7"
Width Front	325 mm / 12.8"	435 mm / 17.1"	514 mm / 20.2"
Width Rear	325 mm / 12.8"	435 mm / 17.1"	514 mm / 20.2"
Depth	282 mm / 11.1"	408 mm / 16.1"	489 mm / 19.3"
<b>Weight</b>			
Net Weight (kg / lbs)	5.5 kg / 12.1 lbs	12.0 kg / 26.4 lbs	22.0 kg / 48.4 lbs
Gross Weight (kg / lbs)	7.5 kg / 16.5 lbs	15.1 kg / 33.2 lbs	26.8 kg / 59.0 lbs



Model Name	Titan-12Z	Titan-15Z
System Type	Passive	Passive
Configuration	12" 2-way	15" 2-way
Frequency Response (+/-3 dB)	55 Hz-20 kHz	45 Hz-20 kHz
Frequency Range (-10 dB)	50 Hz-20 kHz	40 Hz-20 kHz
Sensitivity (2.83 v / 1 m)	99 dB	99 dB
Calculated Maximum SPL @1 m	132 dB	133.5 dB
System Rated Impedance	8 Ω	8 Ω
<b>Low Frequency Transducer</b>		
Size	305 mm / 12"	381 mm / 15"
Voice Coil Size	75 mm / 3.0"	100 mm / 4.0"
Rated Impedance	8 Ω	8 Ω
LF Power (re:AES2-2012)	500 w	700 w
<b>High Frequency Transducer</b>		
HF Driver Type	Compression Driver	Compression Driver
Voice Coil Size	44 mm / 1.75"	50 mm / 2.0"
Exit Size	25 mm / 1"	25 mm / 1"
Diaphragm Material	Titanium	Titanium
Rated Impedance	8 Ω	8 Ω
HF Power (re:AES2-2012)	40 w	50 w
Nominal Coverage (H x V)	Hybrid Symmetry Horn 100°x80°	Hybrid Symmetry Horn 100°x80°
<b>Power</b>		
System Continuous Power	500 w	700 w
System Programme Power	1000 w	1400 w
System Peak Power	2000w	2800 w
Crossover frequency	2.1 kHz	2.1 kHz
Input Connector	2 x NL4 (speakON compatible)	2 x NL4 (speakON compatible)
<b>Hardware</b>		
Pole Mount	35 mm with lock screw	35 mm with lock screw
Handles	2 on sides	2 on sides
Mounting points	M8 * 10	M8 * 10
<b>Enclosure</b>		
Enclosure Material	Trapezoidal / Polypropylene	Trapezoidal / Polypropylene
Finish	Black / white	Black / white
Grille Material & Finish	1.2 steel	1.2 steel
<b>Dimensions - Unpacked</b>		
Height	582.7 mm / 22.9"	728.5 mm / 28.7"
Width Front	384.6 mm / 15.1"	480.6 mm / 18.9"
Width Rear	384.6 mm / 15.1"	480.6 mm / 18.9"
Depth	318.6 mm / 12.5"	395.6 mm / 15.6"
<b>Dimensions - Packed</b>		
Height	663 mm / 26.1"	830 mm / 32.7"
Width Front	435 mm / 17.1"	514 mm / 20.2"
Width Rear	435 mm / 17.1"	514 mm / 20.2"
Depth	408 mm / 16.1"	489 mm / 19.3"
<b>Weight</b>		
Net Weight (kg / lbs)	15.7 kg / 34.5 lbs	25.8 kg / 56.8 lbs
Gross Weight (kg / lbs)	18.8 kg / 41.2 lbs	30.6 kg / 67.3 lbs



# DVP-X Series

ROAD-READY LOUDSPEAKERS SPECIFICALLY DESIGNED FOR HARDWORKING PERFORMERS



Titanium Compression Driver    Durable, Painted Speaker Cabinet    Performance you can depend on    90° x 60° elliptical waveguide    Rhino Rock Paint    Designed for live Performance



The DVP-X range has been specifically built for hardworking musicians and DJ's on the road. Covering all live applications this robust line up covers all sizes from a full range 12" through to the huge 138 dB 2 x 18" subwoofer.

The MDF cabinets of DVP-X series are protected by an enhanced version of Wharfedale Pro's proprietary Rhino Rock paint. This finish gives improved protection against chips, dinks and clunks during transportation to and from the gig. DVP-X will look as good as new even after many successful tours, parties and events. The iconic Wharfedale Pro logo is also CNC routed into the cabinet design.

But DVP-X is more than just a strong cabinet. The drivers use the latest Wharfedale Pro driver technology. For the LF drivers, a curvilinear, double-roll surround is used for smooth mid-high

transitions and stability for low through to mid-range frequencies. All models have 2.5" voice coils for improved thermal dissipation. A 44mm diaphragm IRIS X4 HF driver is used throughout the range. Using a solid aluminium rear plate, the HF driver is strengthened for durability and heat is dissipated efficiently for high pressure use during prolonged time periods. Wharfedale Pro engineers have also selected a 90° x 60° elliptical waveguide optimised for wide coverage in multiple venues while touring.

Special attention has been paid to the port and port mouth to ensure a huge bass output with detail and minimised distortion. For the floor monitors, the port mouth lies parallel to the ground, creating a reflective boundary effect to guarantee low-end delivery. Each port on each speaker has been tuned individually for low-end punch.



- Individually tuned front ported systems for clear, punchy bass
- Enhanced Rhino Rock paint for a chip resistant finish
- Extended-range IRIS X4 Titanium dome HF drivers
- High powered LF drivers using a double-roll surround
- Fine-tuned crossovers, built in house for audio signal purity and optimised tuning
- HF limiters are installed for thermal protection against extreme power input
- 8 models in the passive line up



Model Name	DVP-X12	DVP-X12M	DVP-X15	DVP-X15M
System Type	Passive	Passive	Passive	Passive
Configuration	Two-way	Two-way	Two-way	Two-way
Frequency Response (+/-3 dB)	60-18 kHz	60-18 kHz	50-18 kHz	55-18 kHz
Frequency Range (-10 dB)	55-20 kHz	55-20 kHz	45-20 kHz	50-20 kHz
Sensitivity (2.83 v / 1 m)	98 dB	98 dB	98 dB	98 dB
Calculated Maximum SPL @1 m	129 dB	129 dB	130 dB	130 dB
System Rated Impedance	8 Ω	8 Ω	8 Ω	8 Ω
<b>Low Frequency Transducer</b>				
Size	305 mm / 12"	305 mm / 12"	381 mm / 15"	381 mm / 15"
Voice Coil Size	65 mm / 2.5"	65 mm / 2.5"	65 mm / 2.5"	65 mm / 2.5"
Rated Impedance	8 Ω	8 Ω	8 Ω	8 Ω
LF Power (re:AES2-2012)	300 W	300 W	350 W	350 W
<b>High Frequency Transducer</b>				
HF Driver Type	Compression Driver	Compression Driver	Compression Driver	Compression Driver
Voice Coil Size	44 mm / 1.75"	44 mm / 1.75"	44 mm / 1.75"	44 mm / 1.75"
Exit Size	25 mm / 1"	25 mm / 1"	25 mm / 1"	25 mm / 1"
Diaphragm Material	Titanium	Titanium	Titanium	Titanium
Rated Impedance	8 Ω	8 Ω	8 Ω	8 Ω
HF Power (re:AES2-2012)	40 W	40 W	40 W	40 W
Nominal Coverage (H x V)	90°x60°	90°x60°	90°x60°	90°x60°
Nominal Impedance	8 Ω	8 Ω	8 Ω	8 Ω
<b>Power</b>				
System Continuous Power	300 W	300 W	350 W	350 W
System Programme Power	600 W	600 W	700 W	700 W
System Peak Power	1200 W	1200 W	1400 W	1400 W
Crossover frequency	2.2 kHz	2.2 kHz	2.2 kHz	2.2 kHz
Input Connector	2 x NL4 (speakON compatible) + 1/4" 2 x NL4 (speakON compatible) + 1/4" 2 x NL4 (speakON compatible) + 1/4" Jack combo			
Hardware	Dual-angle (0° / 10°) 35 mm socket	N/A	Dual-angle (0° / 10°) 35 mm socket	N/A
	2 carry handles	2 carry handles	2 carry handles	2 carry handles
<b>Enclosure</b>				
Enclosure Material and finish	MDF	MDF	MDF	MDF
Colour Options	black paint	black paint	black paint	black paint
Grille Material & Finish	steel	steel	steel	steel
<b>Dimensions - Unpacked</b>				
Height	617 mm / 24.3"	428 mm / 16.9"	689 mm / 27.1"	520 mm / 20.5"
Width Front	361.2 mm / 14.2"	359 mm / 14.1"	443.5 mm / 17.5"	449 mm / 17.7"
Width Rear	207.6 mm / 8.2"	359 mm / 14.1"	243.5 mm / 9.6"	449 mm / 17.7"
Depth	342.4 mm / 13.5"	537 mm / 21.1"	429.0 mm / 16.9"	640 mm / 25.2"
<b>Dimensions - Packed</b>				
Height	680 mm / 26.8"	396 mm / 15.6"	750 mm / 29.5"	485 mm / 19.1"
Width Front	438 mm / 17.3"	573 mm / 22.6"	520 mm / 20.5"	676 mm / 26.6"
Width Rear	236 mm / 9.3"	573 mm / 22.6"	290 mm / 11.4"	676 mm / 26.6"
Depth	428 mm / 16.9"	448 mm / 17.6"	485 mm / 19.1"	541 mm / 21.3"
<b>Weight</b>				
Net Weight	17.6 kg / 38.7 lbs	17.4 kg / 38.2 lbs	22 kg / 48.4 lbs	21.5 kg / 47.3 lbs
Gross Weight	20.6 kg / 45.3 lbs	20.5 kg / 45.1 lbs	26 kg / 57.2 lbs	24.5 kg / 53.9 lbs



Model Name	DVP-X215	DVP-X15B	DVP-X18B	DVP-X218B
System Type	Passive	Passive	Passive	Passive
Configuration	Two-way	subwoofer	subwoofer	subwoofer
Frequency Response (+/-3 dB)	45-18 kHz	45-150 Hz	35-150 Hz	35-150 Hz
Frequency Range (-10 dB)	40-20 kHz	38-150 Hz	30-150 Hz	30-150 Hz
Sensitivity (2.83 v / 1 m)	101 dB	98 dB	99 dB	102 dB
Calculated Maximum SPL @1 m	135 dB	130 dB	133 dB	138 dB
System Rated Impedance	4 Ω	4 Ω	4 Ω	4 Ω
<b>Low Frequency Transducer</b>				
Size	2 x 381 mm / 15"	381 mm / 15"	470 mm / 18"	2 x 470 mm / 18"
Voice Coil Size	65 mm / 2.5"	65 mm / 2.5"	65 mm / 2.5"	65 mm / 2.5"
Rated Impedance	8 Ω	4 Ω	4 Ω	8 Ω
LF Power (re:AES2-2012)	700 W	400 W	500 W	1000 W
<b>High Frequency Transducer</b>				
HF Driver Type	Compression Driver	-	-	-
Voice Coil Size	44 mm / 1.75"	-	-	-
Exit Size	25 mm / 1"	-	-	-
Diaphragm Material	Titanium	-	-	-
Rated Impedance	8 Ω	-	-	-
HF Power (re:AES2-2012)	40 W	-	-	-
Nominal Coverage (H x V)	90°x60°	-	-	-
Nominal Impedance	8 Ω	-	-	-
<b>Power</b>				
System Continuous Power	700 W	400 W	500 W	1000 W
System Programme Power	1400 W	800 W	1000 W	2000 W
System Peak Power	2800 W	1600 W	2000 W	4000 W
Crossover frequency	2.2 kHz	150 Hz	150 Hz	
Input Connector	2 x NL4 (speakON compatible) + 1/4" 2 x NL4 (speakON compatible) + 1/4" 2 x NL4 (speakON compatible) + 1/4" Jack combo			
Hardware	N/A	35 mm pole socket	35 mm pole socket	2 x 35 mm pole socket
	2 carry handles	2 carry handles	2 carry handles	2 carry handles
<b>Enclosure</b>				
Enclosure Material and finish	MDF	MDF	MDF	MDF
Colour Options	black paint	black paint	black paint	black paint
Grille Material & Finish	steel	steel	steel	steel
<b>Dimensions - Unpacked</b>				
Height	1058 mm / 41.7"	591 mm / 23.3"	650 mm / 25.6"	650 mm / 25.6"
Width Front	444.5 mm / 17.5"	454 mm / 17.9"	528 mm / 20.8"	1020 mm / 40.2"
Width Rear	245.3 mm / 9.7"	454 mm / 17.9"	528 mm / 20.8"	1020 mm / 40.2"
Depth	429.0 mm / 16.9"	534 mm / 21.0"	639 mm / 25.2"	610 mm / 24.0"
<b>Dimensions - Packed</b>				
Height	1125 mm / 44.3"	681 mm / 26.8"	740 mm / 29.1"	728 mm / 28.7"
Width Front	520 mm / 20.5"	620 mm / 24.4"	725 mm / 28.5"	1092 mm / 43.0"
Width Rear	290 mm / 11.4"	620 mm / 24.4"	725 mm / 28.5"	1092 mm / 43.0"
Depth	496 mm / 19.5"	540 mm / 21.3"	614 mm / 24.2"	685 mm / 27.0"
<b>Weight</b>				
Net Weight	34.5 kg / 75.9 lbs	27.5 kg / 60.5 lbs	35.3 kg / 77.7 lbs	62.5 kg / 137.5 lbs
Gross Weight	38.9 kg / 85.6 lbs	31.5 kg / 69.3 lbs	41.9 kg / 92.2 lbs	71.0 kg / 156.2 lbs



# IMPACT-X Series

OUR AFFORDABLE, POWERFUL PASSIVE SPEAKER RANGE - refreshed !



## 'L' Models

L models boast physical dimensions to match our EVP-X MKII series onstage and deliver increased SPL specifications. The new Quad Layer LF drivers in the IMPACT-X18BL and IMPACT-X218BL also ensure smooth but defined low end punch.



IMPACT-X15ML

IMPACT-X18BL

IMPACT-X218BL



### NL2 Combi jack inputs

All models of IMPACT-X feature versatile NL2 combi jacks. This allows for either speakON compatible cabling OR for 6.3 mm jack plugs to be used.

The IMPACT-X Series has a desirable high power capacity and clarity, as well as an exceptional low frequency output providing tight bass all the way down to a 30 Hz response.

For high frequency, an IRIS X4 1.75" titanium diaphragm compression driver produces a powerful yet neutral sounding high end. All IMPACT-X series speakers use specially developed LF & HF drive units which are acoustically matched with an equally durable cabinet.

### Built to take an Impact

The strong MDF cabinets are covered in a textured black paint to give a durable yet stylish finish, which brings a professional look to any sound reinforcement environment. The finish is extremely hard wearing and is leagues above any other carpet covered cabinet in the same price point.

For both dedicated sound engineers and touring musicians gigging week after week, you will be able to put your trust in the IMPACT-X series.



### IRIS X Compression drivers

The coil size and electrical sensitivity of a loudspeaker transducer is critical to its performance. IMPACT-X loudspeakers use our proprietary IRIS X design which delivers Increased coil Radius and Increased electrical Sensitivity. The radius of the coil ensures smooth heat dissipation during prolonged high volume use, while the increased electrical sensitivity ensures that the transducer converts as much electrical power into sound output as the laws of physics allow.

A hot transducer wastes energy, risks damage and distorts. IRIS X reduces this through improved heat dissipation and improved efficiency.

In real-world terms, IRIS X transducers deliver higher SPL with less distortion. They lead the market with specifications and are designed and built entirely within Wharfedale Pro.



IMPACT-X15L

- An affordable, powerful passive speaker range
- IRIS X4 1.75" titanium diaphragm compression drivers
- 90° x 60° Waveguides
- Newly developed high power LF & HF drivers
- Durable black paint finish
- 2 x NL2 Combi jack inputs
- Dual angle 35 mm speaker pole inputs
- MDF cabinet construction
- Iconic routed Wharfedale Pro Boomerang logo



Model Name	IMPACT-X15	IMPACT-X15L	IMPACT-X15ML	IMPACT-X215	IMPACT-X215L
System Type	Passive	Passive	Passive	Passive	Passive
Configuration	Two-way	Two-way	15" two-way Monitor	Two-way	Two-way
Frequency Response (+/-3 dB)	50-18 kHz	50-18 kHz	55-18 kHz	45-18 kHz	45-18 kHz
Frequency Range (-10 dB)	45-20 kHz	45-20 kHz	50-20 kHz	40-20 kHz	40-20 kHz
Sensitivity (2.83 v / 1 m)	98 dB	98 dB	98 dB	101 dB	101 dB
Calculated Maximum SPL @1 m	130 dB	130 dB	130 dB	135 dB	135 dB
System Rated Impedance	8 Ω	8 Ω	8 Ω	4 Ω	4 Ω
<b>Low Frequency Transducer</b>					
Size	381 mm / 15"	381 mm / 15"	381 mm / 15"	2 x 381 mm / 15"	2 x 381 mm / 15"
Voice Coil Size	65 mm / 2.5"	65 mm / 2.5"	Dual 2 layer 2.5"	65 mm / 2.5"	65 mm / 2.5"
Rated Impedance	8 Ω	8 Ω	8 Ω	2 x 8 Ω	2 x 8 Ω
LF Power (re:AES2-2012)	350 W	350 W	350 W	2 x 350 W	2 x 350 W
<b>High Frequency Transducer</b>					
HF Driver Type	Compression Driver	Compression Driver	Compression Driver	Compression Driver	Compression Driver
Voice Coil Size	44 mm / 1.75"	44 mm / 1.75"	44 mm / 1.75"	44 mm / 1.75"	44 mm / 1.75"
Exit Size	25 mm / 1"	25 mm / 1"	25 mm / 1"	25 mm / 1"	25 mm / 1"
Diaphragm Material	Titanium	Titanium	Titanium	Titanium	Titanium
Rated Impedance	8 Ω	8 Ω	8 Ω	8 Ω	8 Ω
HF Power (re:AES2-2012)	40 W	40 W	40 W	40 W	40 W
Nominal Coverage (H x V)	90° x 60°	90° x 60°	90° x 60°	90° x 60°	90° x 60°
Nominal Impedance	8 Ω	8 Ω	8 Ω	8 Ω	8 Ω
<b>Power</b>					
System Continuous Power	350 W	350 W	350 W	700 W	700 W
System Programme Power	700 W	700 W	700 W	1400 W	1400 W
System Peak Power	1400 W	1400 W	1400 W	2800 W	2800 W
Crossover frequency	2.2 kHz	2.2 kHz	2.2 kHz	2.2 kHz	2.2 kHz
Input Connector	2 x NL2 combi jack	2 x NL2 combi jack	2 x NL2 combi jack	2 x NL2 combi jack	2 x NL2 combi jack
Hardware	Dual-angle (0° or 10°) 35 mm pole socket		N/A	N/A	N/A
	2 carry handles	2 carry handles	2 carry handles	2 carry handles	2 carry handles
<b>Enclosure</b>					
Enclosure Material and finish	MDF	MDF	MDF	MDF	MDF
Colour Options	black paint	black paint	black paint	black paint	black paint
Grille Material & Finish	steel	steel	steel	steel	steel
<b>Dimensions - Unpacked</b>					
Height	680 mm / 26.77"	680 mm / 26.8"	645 mm / 25.39"	1058 mm / 41.7"	1058 mm / 41.7"
Width Front	444.5 mm / 17.5"	460 mm / 18.1"	445 mm / 17.52"	444.5 mm / 17.5"	502 mm / 19.8"
Width Rear	245.3 mm / 9.66"	249.6 mm / 9.8"	445 mm / 17.52"	245.3 mm / 9.7"	282.5 mm / 11.1"
Depth	429 mm / 16.89"	450 mm / 17.7"	505 mm / 19.9"	429.0 mm / 16.9"	467 mm / 18.4"
<b>Dimensions - Packed</b>					
Height	750 mm / 29.53"	759 mm / 29.9"	501 mm / 19.72"	1125 mm / 44.3"	1125 mm / 44.3"
Width Front	520 mm / 20.47"	535 mm / 21.1"	691 mm / 27.2"	520 mm / 20.5"	577 mm / 22.7"
Width Rear	290 mm / 11.42"	295 mm / 11.6"	691 mm / 27.2"	290 mm / 11.4"	327 mm / 12.9"
Depth	485 mm / 19.1"	506 mm / 19.9"	532 mm / 20.94"	496 mm / 19.5"	534 mm / 21.0"
<b>Weight</b>					
Net Weight	22.8 kg / 50.16 lbs	23.5 kg / 51.7 lbs	21.9 kg / 48.2 lbs	34.5 kg / 75.9 lbs	37.1 kg / 81.6 lbs
Gross Weight	25.8 kg / 56.76 lbs	26.6 kg / 58.52 lbs	25.4 kg / 55.9 lbs	38.9 kg / 85.6 lbs	41.6 kg / 91.5 lbs



Model Name	IMPACT-X18B	IMPACT-X18BL	IMPACT-X218B	IMPACT-X218BL
System Type	Passive	Passive	Passive	Passive
Configuration	18" Subwoofer	18" Subwoofer	2x18" Subwoofer	2x18" Subwoofer
Frequency Response (+/-3 dB)	40-220 Hz	40-220 Hz	35 Hz-1.2 kHz	35 Hz-1.2 kHz
Frequency Range (-10 dB)	30-250 Hz	30-250 Hz	30 Hz-1.5 kHz	30 Hz-1.5 kHz
Sensitivity (2.83 v / 1 m)	100 dB	100 dB	101 dB	102 dB
Calculated Maximum SPL @1 m	133 dB	134 dB	137 dB	139 dB
System Rated Impedance	4 Ω	4 Ω	4 Ω	4 Ω
<b>Low Frequency Transducer</b>				
Size	470 mm / 18"	470 mm / 18"	2 x 470 mm / 18"	2 x 470 mm / 18"
Voice Coil Size	65 mm / 2.5"	Quad layer 3.0"	65 mm / 2.5"	Quad layer 3.0"
Rated Impedance	4 Ω	4 Ω	2 x 8 Ω	2 x 8 Ω
LF Power (re:AES2-2012)	500 W	600 W	2 x 500 W	2 x 600 W
<b>High Frequency Transducer</b>				
HF Driver Type	-	-	-	-
Voice Coil Size	-	-	-	-
Exit Size	-	-	-	-
Diaphragm Material	-	-	-	-
Rated Impedance	-	-	-	-
HF Power (re:AES2-2012)	-	-	-	-
Nominal Coverage (H x V)	-	-	-	-
Nominal Impedance	-	-	-	-
<b>Power</b>				
System Continuous Power	500 W	600 W	1000 W	1200 W
System Programme Power	1000 W	1200 W	2000 W	2400 W
System Peak Power	2000 W	2400 W	4000 W	4800 W
Crossover frequency	250 Hz	250 Hz		
Input Connector	2 x NL2 combi jack	2 x NL2 combi jack	2 x NL2 combi jack	2 x NL2 combi jack
Hardware	35 mm pole socket	35 mm pole socket	N/A	N/A
	2 carry handles	2 carry handles	2 carry handles	2 carry handles
<b>Enclosure</b>				
Enclosure Material and finish	MDF	MDF	18 mm MDF	15 mm MDF
Colour Options	black paint	black paint	black paint	black paint
Grille Material & Finish	steel	steel	steel	steel
<b>Dimensions - Unpacked</b>				
Height	526 mm / 20.71"	650 mm / 25.6"	554 mm / 21.81"	650 mm / 25.6"
Width Front	611 mm / 24.06"	528 mm / 20.8"	1222 mm / 48.11"	1020 mm / 40.2"
Width Rear	611 mm / 23.06"	528 mm / 20.8"	1222 mm / 48.11"	1020 mm / 40.2"
Depth	606.5 mm / 23.88"	639 mm / 25.2"	606.5 mm / 23.88"	610 mm / 24.0"
<b>Dimensions - Packed</b>				
Height	635 mm / 25.0"	740 mm / 29.1"	628 mm / 24.72"	728 mm / 28.7"
Width Front	710 mm / 27.95"	725 mm / 28.5"	1295 mm / 50.98"	1092 mm / 43.0"
Width Rear	710 mm / 27.95"	725 mm / 28.5"	1295 mm / 50.98"	1092 mm / 43.0"
Depth	660 mm / 25.98"	614 mm / 24.2"	685 mm / 26.97"	685 mm / 27.0"
<b>Weight</b>				
Net Weight	34.52 kg / 75.9 lbs	40.0 kg / 88.0 lbs	78.9 kg / 173.58 lbs	67.3 kg / 148.06 lbs
Gross Weight	41.2 kg / 90.6 lbs	44.2 kg / 97.3 lbs	83.1 kg / 182.81 lbs	72.6 kg / 159.72 lbs



# EVP-X MKII

**THE PERFECT BALANCE BETWEEN AFFORDABILITY, POWER AND QUALITY.  
A COMPREHENSIVE LINEUP OF MODELS TO FILL YOUR VENUE.**



## The Evolution of EVP

From the EVP, EVP-X and now the EVP-X MKII, we have continually honed and improved this series to make it one of the most well respected and reliable speaker series in the industry. EVP-X MKII serves up an extra 20% power handling and an additional 32 dB SPL over the original EVP-X.



## High power, low distortion, maximum efficiency

Built around the development of an exceptional new Elliptical Waveguide Horn coupled with a Ferro fluid cooled 44 mm titanium compression driver, the high frequency performance and system reliability of this series is unprecedented in this product class. High output capability and low distortion with excellent high frequency extension characterise these new drivers. When comparing sound quality and specifications to the competition, the advantages of Wharfedale Pro built and designed components, the real compression driver and our sophisticated crossover can immediately be heard and appreciated.

## Durable, Versatile Speaker Cabinet

EVP-X MKII is protected by a durable carpet covering and steel grille. EVP-X MKII also features a 4-way carry handle and a dual angle pole mount making it both more portable and more versatile for varying installation applications, ensuring the HF sound is directed straight at your audience.



- Up to 20% extra power handling on new MKII series
- Up to 32 dB additional SPL on new MKII series
- 90° x 60° Elliptical Wave Guide Horn
- 1.75" titanium diaphragm drivers
- ProTech™ Driver protection
- Built in crossover (subwoofers)
- Durable black carpet covering
- Dual angle pole mounts
- Four way carry handle design

The EVP-X15B MKII, EVP-X18B MKII and dual 18" EVP-X218B MKII subwoofers all include a Hi Pass output connector which makes system setup simple and straightforward.





Model Name	EVP-X12 MKII	EVP-X12M MKII	EVP-X15 MKII	EVP-X15M MKII
System Type	Passive	Passive	Passive	Passive
Configuration	Two-way	Two-way Monitor	Two-way	Two-way Monitor
Frequency Response (+/-3 dB)	55 Hz - 20 kHz	60 Hz - 20 kHz	45 Hz - 20 kHz	50 Hz - 20 kHz
Frequency Range (-10 dB)	50 Hz - 20 kHz	55 Hz - 20 kHz	40 Hz - 20 kHz	45 Hz - 20 kHz
Sensitivity (2.83 v / 1 m)	98 dB	98 dB	98 dB	98 dB
Calculated Maximum SPL @1 m	129 dB	129 dB	130 dB	130 dB
System Rated Impedance	8 Ω	8 Ω	8 Ω	8 Ω
<b>Low Frequency Transducer</b>				
Size	305 mm / 12"	305 mm / 12"	381 mm / 15"	381 mm / 15"
Voice Coil Size	51.6 mm / 2"	51.6 mm / 2"	64.26 mm / 2.5"	64.26 mm / 2.5"
Rated Impedance	8 Ω	8 Ω	8 Ω	8 Ω
LF Power (re:AES2-2012)	300 w	300 w	350 w	350 w
<b>High Frequency Transducer</b>				
HF Driver Type	Compression driver	Compression driver	Compression driver	Compression driver
Voice Coil Size	44.5 mm / 1.75"	44.5 mm / 1.75"	44.5 mm / 1.75"	44.5 mm / 1.75"
Exit Size	25 mm / 1"	25 mm / 1"	25 mm / 1"	25 mm / 1"
Diaphragm Material	Titanium	Titanium	Titanium	Titanium
Rated Impedance	8 Ω	8 Ω	8 Ω	8 Ω
HF Power (re:AES2-2012)	40 w	40 w	40 w	40 w
Nominal Coverage (H x V)	90° x 60°	90° x 60°	90° x 60°	90° x 60°
<b>Power</b>				
System Continuous Power	300 w	300 w	350 w	350 w
System Programme Power	600 w	600 w	700 w	700 w
System Peak Power	1200 w	1200 w	1400 w	1400 w
Crossover frequency	2.3 kHz	2.4 kHz	2.2 kHz	2.3 kHz
Input Connector	2 x NL4 (speakON Compatible) + 2 x 1/4" Jacks	2 x NL4 (speakON Compatible) + 2 x 1/4" Jacks	2 x NL4 (speakON Compatible) + 2 x 1/4" Jacks	2 x NL4 (speakON Compatible) + 2 x 1/4" Jacks
<b>Hardware</b>				
Pole Mount	Dual Angle (0° or 10°) 35 mm		Dual Angle (0° or 10°) 35 mm	
Handles	2 on Sides	2 on Sides	2 on Sides	2 on Sides
<b>Enclosure</b>				
Enclosure Material	Particle Board	Particle Board	Particle Board	Particle Board
Finish	Black Carpet	Black Carpet	Black Carpet	Black Carpet
Grille Material & Finish	1.2 mm Steel	1.2mm Steel	1.2 mm Steel	1.2 mm Steel
<b>Dimensions - Unpacked</b>				
Height	590 mm / 23.23"	560 mm / 22.05"	675 mm / 26.57"	645 mm / 25.39"
Width Front	430 mm / 16.93"	424 mm / 16.69"	460 mm / 18.11"	445 mm / 17.52"
Width Rear	297.5 mm / 11.71"	424 mm / 16.69"	294.5 mm / 11.59"	445 mm / 17.52"
Depth	370 mm / 14.57"	441 mm / 17.36"	45 mm / 17.72"	473.5 mm / 18.64"
<b>Dimensions - Packed</b>				
Height	655 mm / 25.79"	480 mm / 18.9"	750 mm / 29.53"	501 mm / 19.72"
Width Front	492 mm / 19.37"	616 mm / 24.25"	524 mm / 21.02"	691 mm / 27.2"
Width Rear	328 mm / 12.91"	616 mm / 24.25"	324 mm / 12.76"	691 mm / 27.2"
Depth	408 mm / 16.06"	490 mm / 19.29"	486 mm / 19.13"	532 mm / 20.94"
<b>Weight</b>				
Net Weight (kg / lbs)	18.92 kg / 41.6 lbs	17.96 kg / 39.5 lbs	23.92 kg / 52.6 lbs	20.9 kg / 45.98 lbs
Gross Weight (kg / lbs)	21.6 kg / 47.5 lbs	20.56 kg / 45.2 lbs	27.42 kg / 60.3 lbs	24.4 kg / 53.7 lbs

Model Name	EVP-X215 MKII	EVP-X15B MKII	EVP-X18B MKII	EVP-X218B MKII
System Type	Passive	Passive	Passive	Passive
Configuration	Quassi Three-way	Subwoofer	Subwoofer	Subwoofer
Frequency Response (+/-3 dB)	40 Hz - 20 kHz	40 Hz - 250 Hz	35 Hz - 250 Hz	30 Hz - 250 Hz
Frequency Range (-10 dB)	35 Hz - 20 kHz	35 Hz - 250 Hz	30 Hz - 250 Hz	28 Hz - 250 Hz
Sensitivity (2.83 v / 1 m)	100 dB	99 dB	100 dB	107 dB
Calculated Maximum SPL @1 m	135 dB	131 dB	134 dB	137 dB
System Rated Impedance	4 Ω	4 Ω	4 Ω	4 Ω
<b>Low Frequency Transducer</b>				
Size	381 mm / 15"	381 mm / 15"	470 mm / 18"	470 mm / 18"
Voice Coil Size	64.26 mm / 2.5"	64.26 mm / 2.5"	76.2 mm / 3"	76.2 mm / 3"
Rated Impedance	8 Ω	4 Ω	4 Ω	8 Ω
LF Power (re:AES2-2012)	2 x 350 w	400 w	600 w	2 x 600 w
<b>High Frequency Transducer</b>				
HF Driver Type	Compression driver	-	-	-
Voice Coil Size	44.5 mm / 1.75"	-	-	-
Exit Size	25 mm / 1"	-	-	-
Diaphragm Material	Titanium	-	-	-
Rated Impedance	8 Ω	-	-	-
HF Power (re:AES2-2012)	40 w	-	-	-
Nominal Coverage (H x V)	90° x 60°	-	-	-
<b>Power</b>				
System Continuous Power	700 w	400 w	600 w	1200 w
System Programme Power	1400 w	800 w	1200 w	2400 w
System Peak Power	2800 w	1600 w	2400 w	4800 w
Crossover frequency	2.3 kHz	150 Hz	150 Hz	150 Hz
Input Connector	2 x NL4 (speakON Compatible) + 2 x 1/4" Jacks	2 x NL4 (speakON Compatible) + 2 x 1/4" Jacks	2 x NL4 (speakON Compatible) + 2 x 1/4" Jacks	2 x NL4 (speakON Compatible) + 2 x 1/4" Jacks
<b>Hardware</b>				
Pole Mount		35 mm Pole Socket	35 mm Pole Socket	35 mm Pole Socket
Handles	2 on Sides	2 on Sides	2 on Sides	2 on Sides
<b>Enclosure</b>				
Enclosure Material	Particle Board	Particle Board	Particle Board	Particle Board
Finish	Black Carpet	Black Carpet	Black Carpet	Black Carpet
Grille Material & Finish	1.2 mm Steel	1.2 mm Steel	1.2 mm Steel	1.2 mm Steel
<b>Dimensions - Unpacked</b>				
Height	1058 mm / 41.65"	591 mm / 23.27"	650 mm / 24.02"	650 mm / 25.59"
Width Front	502 mm / 19.76"	460 mm / 18.11"	522 mm / 20.55"	610 mm / 24.02"
Width Rear	330 mm / 12.99"	460 mm / 18.11"	522 mm / 20.55"	610 mm / 24.02"
Depth	467 mm / 18.39"	510 mm / 20.08"	610 mm / 24.02"	1020 mm / 40.16"
<b>Dimensions - Packed</b>				
Height	1123 mm / 44.21"	656 mm / 25.83"	715 mm / 28.15"	765 mm / 30.12"
Width Front	564 mm / 22.2"	556 mm / 21.89"	656 mm / 25.83"	710 mm / 27.95"
Width Rear	362 mm / 14.25"	556 mm / 21.89"	656 mm / 25.83"	710 mm / 27.95"
Depth	496 mm / 19.53"	506 mm / 19.92"	568 mm / 22.36"	1120 mm / 44.09"
<b>Weight</b>				
Net Weight (kg / lbs)	41.28 kg / 90.8 lbs	28.06 kg / 61.7 lbs	39.3 kg / 66.5 lbs	67 kg / 147.4 lbs
Gross Weight (kg / lbs)	46.06 kg / 101.3 lbs	31.06 kg / 68.3 lbs	42.6 kg / 93.7 lbs	77 kg / 169.4 lbs



# EVO-X Series

GREAT SOUNDING, RELIABLE PA.



The new EVO-X Series strikes the perfect balance between affordability and performance. Positioned in-between the Impact Series and the Delta Series of passive loudspeakers, EVO-X is a new multipurpose lineup of 8 models featuring many useful and practical design elements. All models benefit from a hardwearing Rhino Rock paint finish and are visually enhanced with the iconic Wharfedale Pro 'boomerang' logo being engraved onto their surface. All models also feature practical 4-way handles to make transportation simple and pain-free. Full range models feature a unique +3 dB HF boost switch allowing for quick, on-stage tweaks to be made to the sound as the crowd grows while the 3 subwoofer options all have high pass filter outputs, reducing onstage cabling and peripherals. Robust crossover designs, elliptical waveguides and large voice coils ensure that the sound quality is as beautiful as the cosmetic design.

**Simply - great sounding and reliable PA!**

- MDF Construction and Rhino Rock paint finish
- High power, arrayable trapezoidal cabinets
- 90° x 60° elliptical waveguides
- 4-way rubberised handles
- +3 dB HF Frequency boost switch
- Subwoofers feature internal crossover
- NL4 (speakON compatible) and 1/4" connectors
- Iconic Wharfedale Pro boomerang engraving

**FULL RANGE MODELS**

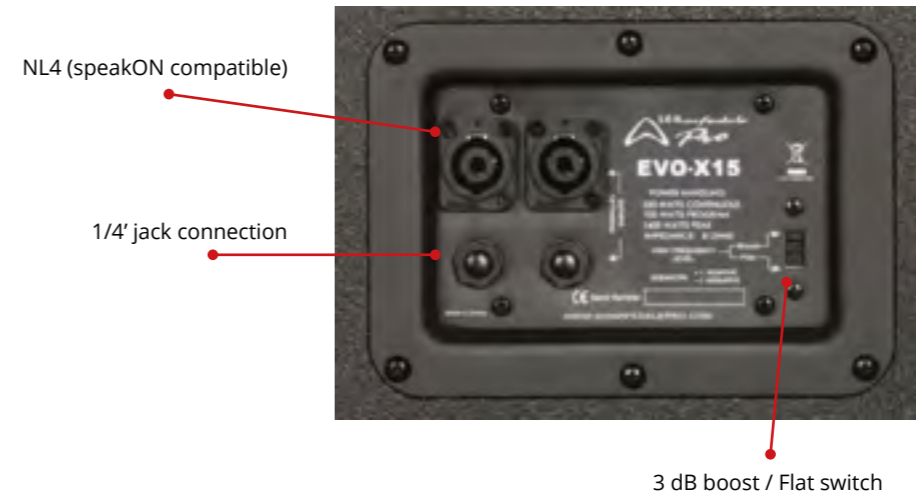

**SUBWOOFERS**

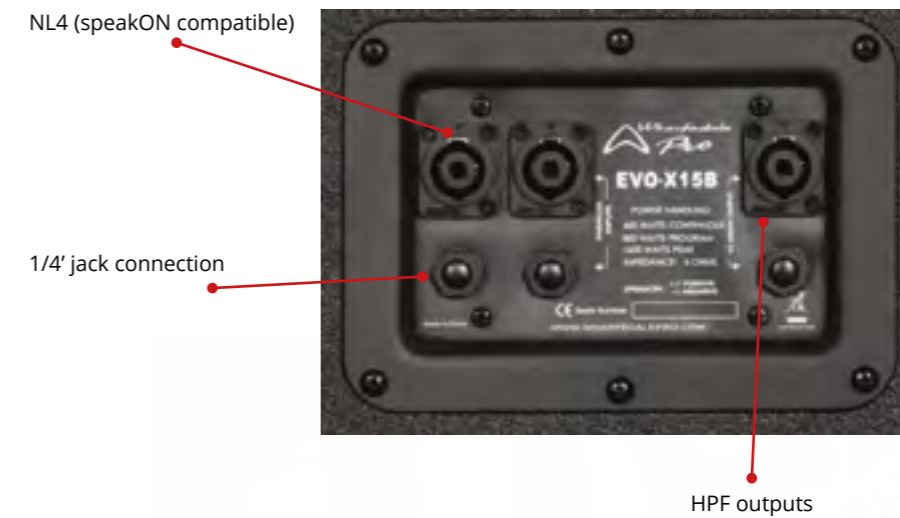

All models feature 4-way rubberised handles

MDF Construction with Rhino rock paint finish

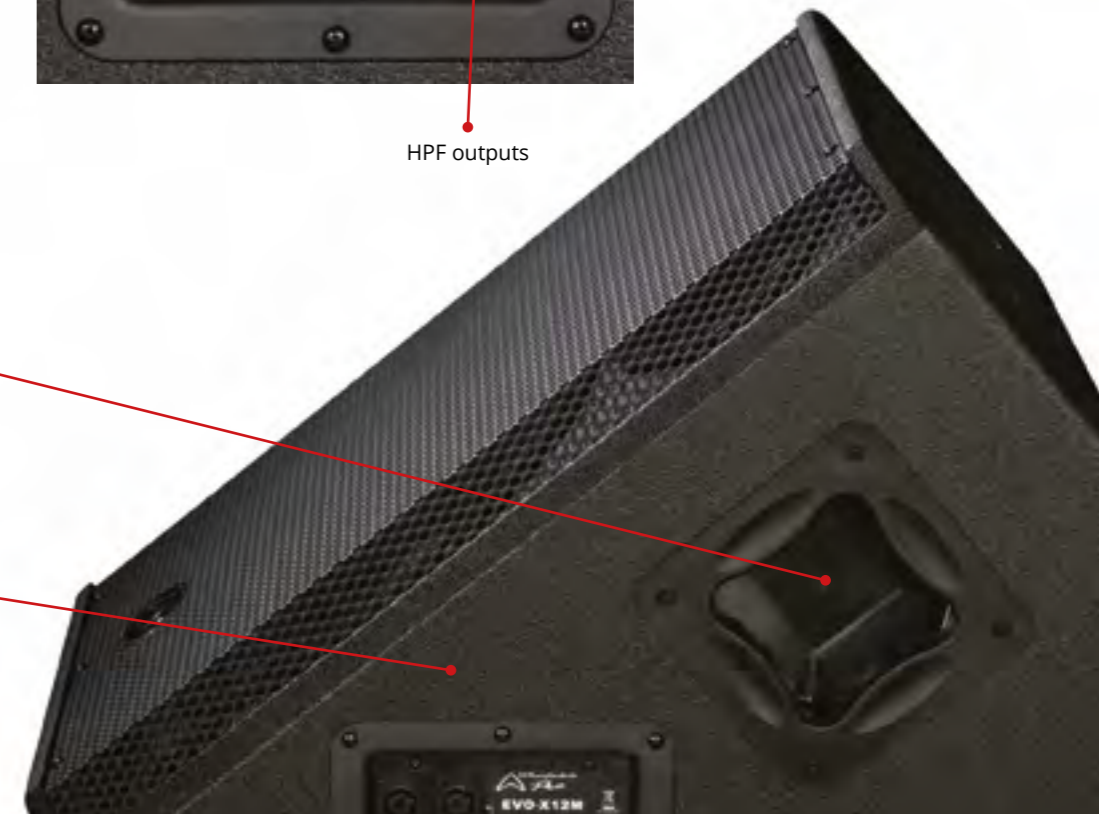

SPECIFICATIONS



Model Name	EVO-X12	EVO-X12M	EVO-X15	EVO-X15M
System Type	Passive	Passive	Passive	Passive
Configuration	Two-way	Two-way Monitor	Two-way	Two-way Monitor
Frequency Response (+/-3 dB)	55 Hz - 20 kHz	60 Hz - 20 kHz	45 Hz - 20 kHz	50 Hz - 20 kHz
Frequency Range (-10 dB)	50 Hz - 20 kHz	55 Hz - 20 kHz	40 Hz - 20 kHz	45 Hz - 20 kHz
Sensitivity (2.83 v / 1 m)	98 dB	98 dB	98 dB	98 dB
Calculated Maximum SPL @1 m	129 dB	129 dB	130 dB	130 dB
System Rated Impedance	8 Ω	8 Ω	8 Ω	8 Ω
<b>Low Frequency Transducer</b>				
Size	305 mm / 12"	305 mm / 12"	381 mm / 15"	381 mm / 15"
Voice Coil Size	51.6 mm / 2"	51.6 mm / 2"	64.26 mm / 2.5"	64.26 mm / 2.5"
Rated Impedance	8 Ω	8 Ω	8 Ω	8 Ω
LF Power (re:AES2-2012)	300 w	300 w	350 w	350 w
<b>High Frequency Transducer</b>				
HF Driver Type	Compression Driver	Compression Driver	Compression Driver	Compression Driver
Voice Coil Size	44.5 mm / 1.75"	44.5 mm / 1.75"	44.5 mm / 1.75"	44.5 mm / 1.75"
Exit Size	25 mm / 1"	25 mm / 1"	25 mm / 1"	25 mm / 1"
Diaphragm Material	Titanium	Titanium	Titanium	Titanium
Rated Impedance	8 Ω	8 Ω	8 Ω	8 Ω
HF Power (re:AES2-2012)	40 w	40 w	40 w	40 w
Nominal Coverage (H x V)	90° x 60°	90° x 60°	90° x 60°	90° x 60°
<b>Power</b>				
System Continuous Power	300 w	300 w	350 w	350 w
System Programme Power	600 w	600 w	700 w	700 w
System Peak Power	1200 w	1200 w	1400 w	1400 w
Crossover frequency	2.3 kHz	2.4 kHz	2.2 kHz	2.3 kHz
Input Connector	2 x NL4 (speakON Compatible) + 2 x 1/4" Jacks	2 x NL4 (speakON Compatible) + 2 x 1/4" Jacks	2 x NL4 (speakON Compatible) + 2 x 1/4" Jacks	2 x NL4 (speakON Compatible) + 2 x 1/4" Jacks
<b>Hardware</b>				
Pole Mount	Dual Angle (0° / 10°) 35 mm Socket		Dual Angle (0° / 10°) 35 mm Socket	
Handles	2 on Sides	2 on Sides	2 on Sides	2 on Sides
<b>Enclosure</b>				
Enclosure Material	MDF	MDF	MDF	MDF
Finish	Rhino rock black paint	Rhino rock black paint	Rhino rock black paint	Rhino rock black paint
Grille Material & Finish	1.2 mm Steel	1.2 mm Steel	1.2 mm Steel	1.2 mm Steel
<b>Dimensions - Unpacked</b>				
Height	590 mm / 23.23"	560 mm / 22.05"	675 mm / 26.57"	645 mm / 25.39"
Width Front	430 mm / 16.93"	424 mm / 16.69"	460 mm / 18.11"	445 mm / 17.52"
Width Rear	297.5 mm / 11.71"	424 mm / 16.69"	294.5 mm / 11.59"	445 mm / 17.52"
Depth	370 mm / 14.57"	441 mm / 17.36"	450 mm / 17.72"	473.5 mm / 18.64"
<b>Dimensions - Packed</b>				
Height	655 mm / 25.79"	480 mm / 18.9"	750 mm / 29.53"	501 mm / 19.72"
Width Front	492 mm / 19.37"	616 mm / 24.25"	524 mm / 21.02"	691 mm / 27.2"
Width Rear	328 mm / 12.91"	616 mm / 24.25"	324 mm / 12.76"	691 mm / 27.2"
Depth	408 mm / 16.06"	490 mm / 19.29"	486 mm / 19.13"	532 mm / 20.94"
<b>Weight</b>				
Net Weight (kg / lbs)	19.2 kg / 42.2 lbs	18.1 kg / 39.8 lbs	24.7 kg / 54.3 lbs	21.4 kg / 47.1 lbs
Gross Weight (kg / lbs)	22.4 kg / 49.3 lbs	21.5 kg / 47.3 lbs	28.4 kg / 62.3 lbs	25.3 kg / 55.7 lbs



Model Name	EVO-X215	EVO-X15B	EVO-X18B	EVO-X218B
System Type	Passive	Passive	Passive	Passive
Configuration	Quasi Three-way	Subwoofer	Subwoofer	Subwoofer
Frequency Response (+/-3 dB)	40 Hz - 20 kHz	40 Hz - 250 Hz	35 Hz - 250 Hz	30 Hz - 250 Hz
Frequency Range (-10 dB)	35 Hz - 20 kHz	35 Hz - 250 Hz	30 Hz - 250 Hz	28 Hz - 250 Hz
Sensitivity (2.83 v / 1 m)	100 dB	99 dB	100 dB	107 dB
Calculated Maximum SPL @1 m	135 dB	131 dB	134 dB	137 dB
System Rated Impedance	4 Ω	4 Ω	4 Ω	4 Ω
<b>Low Frequency Transducer</b>				
Size	381 mm / 15"	381 mm / 15"	470 mm / 18"	470 mm / 18"
Voice Coil Size	64.26 mm / 2.5"	64.26 mm / 2.5"	76.2 mm / 3"	76.2 mm / 3"
Rated Impedance	8 Ω	4 Ω	4 Ω	8 Ω
LF Power (re:AES2-2012)	2 x 350 w	400 w	600 w	2 x 600 w
<b>High Frequency Transducer</b>				
HF Driver Type	Compression Driver	-	-	-
Voice Coil Size	44.5 mm / 1.75"	-	-	-
Exit Size	25 mm / 1"	-	-	-
Diaphragm Material	Titanium	-	-	-
Rated Impedance	8 Ω	-	-	-
HF Power (re:AES2-2012)	40 w	-	-	-
Nominal Coverage (H x V)	90° x 60°	-	-	-
<b>Power</b>				
System Continuous Power	700 w	400 w	600 w	1200 w
System Programme Power	1400 w	800 w	1200 w	2400 w
System Peak Power	2800 w	1600 w	2400 w	4800 w
Crossover frequency	2.3 kHz	150 Hz	150 Hz	150 Hz
Input Connector	2 x NL4 (speakON Compatible) + 2 x 1/4" Jacks	2 x NL4 (speakON Compatible) + 2 x 1/4" Jacks	2 x NL4 (speakON Compatible) + 2 x 1/4" Jacks	2 x NL4 (speakON Compatible) + 2 x 1/4" Jacks
<b>Hardware</b>				
Pole Mount		35 mm Pole Socket	35 mm Pole Socket	35 mm Pole Socket
Handles	2 on Sides	2 on Sides	2 on Sides	2 on Sides
<b>Enclosure</b>				
Enclosure Material	MDF	MDF	MDF	MDF
Finish	Rhino rock black paint	Rhino rock black paint	Rhino rock black paint	Rhino rock black paint
Grille Material & Finish	1.2 mm Steel	1.2 mm Steel	1.2 mm Steel	1.2 mm Steel
<b>Dimensions - Unpacked</b>				
Height	1058 mm / 41.65"	591 mm / 23.27"	650 mm / 24.02"	650 mm / 25.59"
Width Front	502 mm / 19.76"	460 mm / 18.11"	522 mm / 20.55"	610 mm / 24.02"
Width Rear	330 mm / 12.99"	460 mm / 18.11"	522 mm / 20.55"	610 mm / 24.02"
Depth	467 mm / 18.39"	510 mm / 20.08"	610 mm / 24.02"	1020 mm / 40.16"
<b>Dimensions - Packed</b>				
Height	1123 mm / 44.21"	656 mm / 25.83"	715 mm / 28.15"	765 mm / 30.12"
Width Front	564 mm / 22.2"	556 mm / 21.89"	656 mm / 25.83"	710 mm / 27.95"
Width Rear	362 mm / 14.25"	556 mm / 21.89"	656 mm / 25.83"	710 mm / 27.95"
Depth	496 mm / 19.53"	506 mm / 19.92"	568 mm / 22.36"	1120 mm / 44.09"
<b>Weight</b>				
Net Weight (kg / lbs)	42.0 kg / 92.4 lbs	28.5 kg / 62.7 lbs	40.1 kg / 88.2 lbs	67.3 kg / 148.1 lbs
Gross Weight (kg / lbs)	47.1 kg / 103.6 lbs	33.5 kg / 73.7 lbs	45.2 kg / 99.4 lbs	79.9 kg / 175.8 lbs



# DELTA X

## DURABLE PASSIVE PA FOR THE MOST DEMANDING PERFORMERS



2" Titanium  
Compression HF



Low Distortion,  
Maximum Efficiency



Ready for Rigging



Performance you can  
depend on



Rhino Rock Paint



### Performance you can depend on

The Delta X Series uses robust technology and durable components to ensure that it can meet the demands of touring, rental and fixed installation applications

### Ready for a life time on the road

The Delta X Series is constructed from plywood and features dual angle pole mounts to ensure that your sound is aimed directly at the audience, not at the ceiling. Delta-X also has a new crossover construction process, which results in reliable long term performance - even at the highest of volumes.

### Crafted with the highest quality components

High output, low distortion cast frame woofers with 3" voice coils are used throughout the range for unparalleled low frequency reproduction. With the exception of the Delta X10, 2" titanium compression drivers are coupled to 90° x 45° elliptical waveguides for impressive output level and smooth HF dispersion

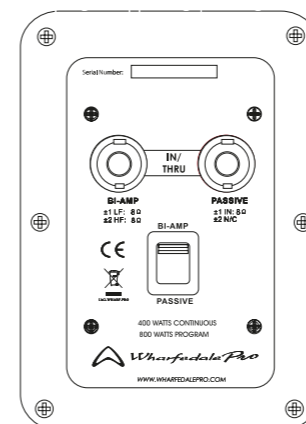

Externally switchable full range/bi-amp operation

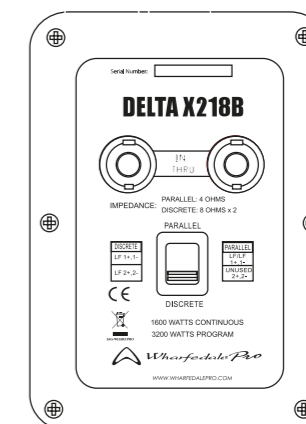

Externally switchable discrete/parallel operation on Delta X218B

- High power, low distortion cast frame woofers
- 1.4" exit, 2" titanium diaphragm compression drivers (1" exit, 1.7" driver Delta X10)
- Externally switchable fullrange / bi-amp operation
- Externally switchable discrete / parallel mode (only Delta X218B)
- 90° x 45° elliptical waveguides (90° x 60° Delta X10)
- Dual angle pole mount receptacles
- Plywood construction with internal bracing
- 4-way high impact plastic carry handles
- Rhino Rock texturised composite finish
- Parallel NL4 (speakON compatible) inputs
- Thru outputs on "M" models
- High-pass outputs on X15B and X18B



**Delta F18B** - Our passive, single 18" folded horn subwoofer delivering a massive 141 dB (max SPL) .

Delta F18B is supplied with castors so is a surprisingly portable and easily moveable enclosure. Where significant extension of low frequency output of a sound system is required over middle-long distances the addition of one or more Delta F18B subwoofers will provide high output low frequency enhancement to the overall sound system.

The folded horn design enables the Delta F18B to deliver ground shaking low frequencies over long distances (Unlike direct radiating designs which provide near to middle distance sound).



Model Name	Delta X10	Delta X12	Delta X15	Delta X12M	Delta X15M
System Type	Passive	Passive	Passive	Passive	Passive
Configuration	Two-way	Two-way	Two-way	Two-way	Two-way
Frequency Response (+/-3 dB)	65-20 kHz	60-20 kHz	50-20 kHz	60-20 kHz	55-20 kHz
Frequency Range (-10 dB)	60-20 kHz	55-20 kHz	45-20 kHz	55-20 kHz	50-20 kHz
Sensitivity (2.83 v / 1 m)	97 dB	97 dB	98 dB	97 dB	98 dB
Calculated Maximum SPL @1 m	128 dB	129 dB	131 dB	129 dB	131 dB
System Rated Impedance	8 Ω	8 Ω	8 Ω	8 Ω	8 Ω

**Low Frequency Transducer**

Size	288 mm / 10"	332 mm / 12"	404 mm / 15"	332 mm / 12"	404 mm / 15"
Voice Coil Size	63.5 mm / 2.5"	77.1 mm / 3"	77.1 mm / 3"	77.1 mm / 3"	77.1 mm / 3"
Rated Impedance	8 Ω	8 Ω	8 Ω	8 Ω	8 Ω
LF Power (re:AES2-2012)	300 w	400 w	500 w	400 w	500 w

**High Frequency Transducer**

HF Driver Type	Compression Driver	Compression Driver	Compression Driver	Compression Driver	Compression Driver
Voice Coil Size	44.5 mm / 1.75" Titanium	50.8 mm / 2" Titanium	50.8 mm / 2" Titanium	50.8 mm / 2" Titanium	50.8 mm / 2" Titanium
Exit Size	25.4 mm / 1"	35.6 mm / 1.4"	35.6 mm / 1.4"	35.6 mm / 1.4"	35.6 mm / 1.4"
Diaphragm Material	Titanium	Titanium	Titanium	Titanium	Titanium
Rated Impedance	8 Ω	8 Ω	8 Ω	8 Ω	8 Ω
HF Power (re:AES2-2012)	40 w	50 w	50 w		
Nominal Coverage (H x V)	90° x 60°	90° x 45°	90° x 45°		

**Power**

System Continuous Power	300 w	400 w	500 w	400 w	500 w
System Programme Power	600 w	800 w	1000 w	800 w	1000 w
System Peak Power	1200 w	1600 w	2000 w	1600 w	2000 w
Crossover frequency	2.8 kHz	1.8 kHz	1.8 kHz	1.8 kHz	1.8 kHz
Input Connector	2 x NL4 (speakON Compatible) 2 x NL4 (speakON Compatible) 2 x NL4 (speakON Compatible) 2 x NL4 (speakON Compatible) 2 x NL4 (speakON Compatible)				

**Hardware**

Pole Mount	Dual Angle (0°/10°) 35 mm	Dual Angle (0°/10°) 35 mm	Dual Angle (0°/10°) 35 mm		
Handles	2 on Sides	2 on Sides	2 on Sides	2 on Sides	2 on Sides

**Enclosure**

Enclosure Material	15 mm Plywood	15 mm Plywood	15 mm Plywood	15 mm Plywood	15 mm Plywood
Finish	Rhino Rock	Rhino Rock	Rhino Rock	Rhino Rock	Rhino Rock
Grille Material & Finish	1.5 mm Steel Black or White	1.5 mm Steel Black	1.5 mm Steel Black	1.5 mm Steel Black	1.5 mm Steel Black

**Dimensions - Unpacked**

Height	500 mm / 19.7"	630 mm / 24.8"	700 mm / 27.6"	449 (SITU)mm / 17.7"	493 (SITU)mm / 19.4"
Width Front	338 mm / 13.3"	390 mm / 15.3"	446 mm / 17.6"	390 mm / 15.4"	446 mm / 17.6"
Width Rear	212.4 mm / 8.4"	241.2 mm / 9.5"	281.4 mm / 11.1"	390 mm / 15.4"	446 mm / 17.6"
Depth	330 mm / 13"	373 mm / 14.7"	406 mm / 16.0"	618 mm / 24.3"	685 mm / 27.0"

**Dimensions - Packed**

Height	575 mm / 22.6"	773 mm / 28.9"	803 mm / 31.6"	462 mm / 18.2"	518 mm / 20.4"
Width Front	400 mm / 15.7"	566 mm / 22.3"	622 mm / 24.5"	690 mm / 27.2"	757 mm / 29.8"
Width Rear	300 mm / 11.8"	566 mm / 22.3"	622 mm / 24.5"	690 mm / 27.2"	757 mm / 29.8"
Depth	386 mm / 15.2"	464 mm / 18.3"	498 mm / 19.6"	522 mm / 20.6"	565 mm / 22.2"

**Weight**

Net Weight (kg / lbs)	16.58 kg / 36.5 lbs	24.7 kg / 54.5 lbs	29.9 kg / 65.9 lbs	23.18 kg / 50.9 lbs	27.24 kg / 59.9 lbs
Gross Weight (kg / lbs)	19.6 kg / 43.0 lbs	29 kg / 63.8 lbs	35.5 kg / 78.1 lbs	28.5 kg / 62.7 lbs	33.96 kg / 74.7 lbs



Model Name	Delta X215	Delta X15B	Delta X18B	Delta X218B	Delta F18B
System Type	Passive	Passive	Passive	Passive	Passive
Configuration	Quasi Three-way	Subwoofer	Subwoofer	Dual Chamber Subwoofer	Folded horn subwoofer
Frequency Response (+/-3 dB)	45-20 kHz	42-2 kHz(BI-AMP)	38-1.5 kHz(BI-AMP)	30-1.5 kHz	30 Hz - 300 Hz
Frequency Range (-10 dB)	45-20 kHz	38-150 Hz	30-1.5 kHz	30-1.5 kHz	
Sensitivity (2.83 v / 1 m)	101 dB	98 dB	99 dB	100 dB	106 dB
Calculated Maximum SPL @1 m	137 dB	132 dB	134 dB	138 dB	141 dB
System Rated Impedance	4 Ω	8 Ω	8 Ω	Parallel: 4 Ω Discrete: 8 Ω x 2	8 Ω

**Low Frequency Transducer**

Size	2 x 404 mm / 15"	404 mm / 15"	470 mm / 18"	470 mm / 18"	470 mm / 18"
Voice Coil Size	77.1 mm / 3"	102 mm / 4"	102 mm / 4"	102 mm / 4"	102 mm / 4"
Rated Impedance	2 x 8 Ω	8 Ω or 4 Ω	8 Ω or 4 Ω	2 x 8 Ω	8 Ω
LF Power (re:AES2-2012)	2 x 500 w	700 w	800 w	2 x 800 w	800 w

**High Frequency Transducer**

HF Driver Type	Compression Driver	-	-	-	-
Voice Coil Size	50.8 mm / 2"	-	-	-	-
Exit Size	35.6 mm / 1.4"	-	-	-	-
Diaphragm Material	Titanium	-	-	-	-
Rated Impedance	8 Ω	-	-	-	-
HF Power (re:AES2-2012)	50 w	-	-	-	-
Nominal Coverage (H x V)	90° x 45°	-	-	-	-

**Power**

System Continuous Power	1000 w	700 w	800 w	1600 w Parallel / 800 w Discrete	800 w
System Programme Power	2000 w	1400 w	1600 w	3200 w Parallel / 1600 w Discrete	1600 w
System Peak Power	4000 w	2800 w	3200 w	6400 w Parallel / 3200 w Discrete	3200 w
Crossover frequency	1.8 kHz	-	-	-	
Input Connector	2 x NL4 (speakON Compatible)	2 x NL4 (speakON Compatible)	2 x NL4 (speakON Compatible)	2 x NL4 (speakON Compatible)	2 x NL4 (speakON Compatible)

**Hardware**

Pole Mount		35 mm	35 mm		35 mm
Handles	2 on Sides / 1 on Back	2 on Sides	2 on Sides	4 on Sides	4 on Sides

**Enclosure**

Enclosure Material	15 mm Plywood	15 mm Plywood	15 mm Plywood	18 mm Plywood	18 mm Plywood
Finish	Rhino Rock	Rhino Rock	Rhino Rock	Rhino Rock	Rhino Rock
Grille Material & Finish	1.5 mm Steel Black	1.5 mm Steel Black	1.5 mm Steel Black	1.5 mm Steel Black	

**Dimensions - Unpacked**

Height	1135 mm / 44.7"	471 mm / 18.5"	539 mm / 21.2"	541 mm / 21.3"	914 mm / 36.0"
Width Front	488 mm / 19.2"	471 mm / 18.5"	539 mm / 21.2"	1041 mm / 41.0"	609.6 mm / 24.0"
Width Rear	299.6 mm / 11.8"	471 mm / 18.5"	539 mm / 21.2"	1041 mm / 41.0"	609.6 mm / 24.0"
Depth	450 mm / 17.7"	600 mm / 23.6"	650 mm / 25.6"	650 mm / 25.6"	914 mm / 36.0"

**Dimensions - Packed**

Height	1218 mm / 48.0"	556 mm / 21.9"	624 mm / 24.6"	626 mm / 25.6"	1009 mm / 39.72"
Width Front	558 mm / 22.0"	543 mm / 21.4"	611 mm / 24.1"	1126 mm / 44.3"	689 mm / 27.12"
Width Rear	558 mm / 22.0"	543 mm / 21.4"	611 mm / 24.1"	1126 mm / 44.3"	689 mm / 27.12"
Depth	522 mm / 20.6"	672 mm / 26.5"	722 mm / 28.4"	722 mm / 28.4"	994 mm / 39.13"

**Weight**

Net Weight (kg / lbs)	52.9 kg / 116.6 lbs	31.5 kg / 69.4 lbs	37.3 kg / 82.06 lbs	78.9 kg / 173.9 lbs	80.5 kg / 177.1 lbs
Gross Weight (kg / lbs)	59.0 kg / 130.0 lbs	35.12 kg / 77.4 lbs	43.2 kg / 95.04 lbs	86.0 kg / 189.6 lbs	85.2 kg / 187.44 lbs



# Reason-X series

3-WAY PA

**NEW**



Reason-X12

Reason-X218B

Reason-X15

Reason-X18B

## Reasons to be cheerful, 1 -2 -3....

### A NEW THREE-WAY SYSTEM - with matching subs.

Built exclusively to deliver incredible sonic definition at high volumes, Reason-X series brings new concepts and new qualities to become the premium pro audio loudspeaker series in the Wharfedale Pro portfolio.

The full range models (X12 and X15) feature an all-new Polyethylene flat diaphragm neodymium HF. This highly engineered Z38 HF compression driver brings extreme HF clarity. Enormous cooling fins disperse the heat generated and the unique 1.5 inch ringshaped polyethylene flat diaphragm delivers a precious feeling of space and air to high frequencies.

The 100° x 70° waveguide is also rotatable, making Reason-X suitable for high quality installations and touring.

The mid-range comes from a custom Wharfedale Pro 8" driver with an aluminium basket and ferrite magnet and it delivers a warmth and clarity. Meanwhile, the LF driver boasts a 3.0" voice coil and large φ190 mm ferrite magnet. This 3-way combination gives the Reason series full range models a frequency response and audio definition that simply has to be experienced.

The series is completed by 2 subwoofers. A single 18" and a floor destroying 148 dB Max SPL dual 18". New LF drivers have been created which feature NOMEX spiders for extreme suspension and durability. 4.0" voice coils and a newly designed aluminium basket make these LF transducers impossible to describe in words - they need listening to instead!

All models are constructed of premium baltic birch and use thick steel front grilles for extreme durability. Put simply...3 is better than 2 !



## Full range models



### Reason-X12

12" 3-way model  
All new Z38 PE HF Compression driver  
8.0" mid range  
3.0" LF voice coil with φ190 mm ferrite magnet  
Rotatable horn & 12 x M8 rigging points  
Max SPL @1m. 131 dB

500 W AES (RMS) 1000 W PRG 2000 W PEAK



### Reason-X15

15" 3-way model  
All new Z38 PE HF Compression driver  
8.0" mid range  
3.0" LF voice coil with φ190 mm ferrite magnet  
Rotatable horn & 12 x M8 rigging points  
Max SPL @1m. 133 dB

600 W AES (RMS) 1200 W PRG 2400 W PEAK

## Subwoofers



### Reason-X18B

18" Subwoofer  
Premium baltic birch construction  
4.0" voice coil  
NOMEX Spider  
Aluminium basket

1000 W AES (RMS) 2000 W PRG 4000 W PEAK



### Reason-X218B

Dual 18" Subwoofer  
Premium baltic birch construction  
4.0" voice coils  
NOMEX Spiders  
Aluminium baskets

2000 W AES (RMS) 4000 W PRG 8000 W PEAK

CURVES

The drivers and plywood construction of Reason-X lead to some impressive graphs !

Reason-X12

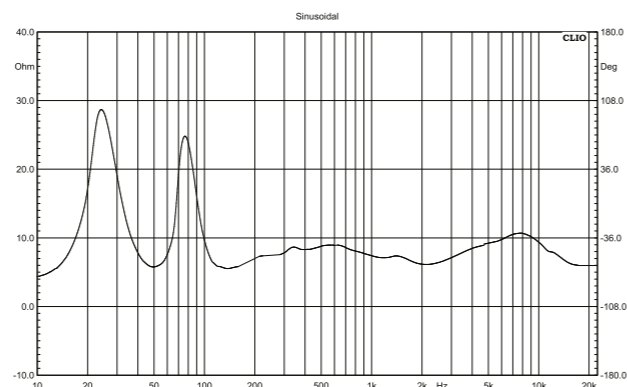
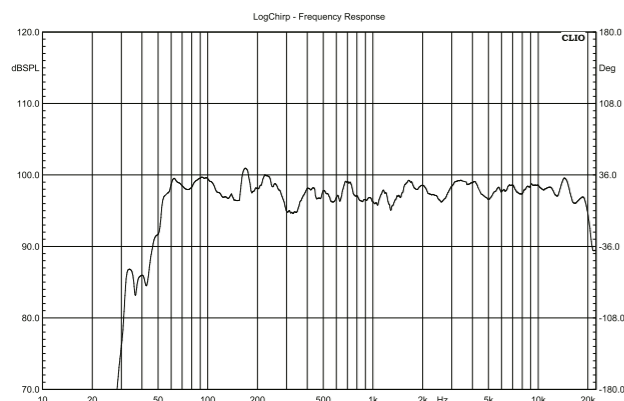

Reason-X15

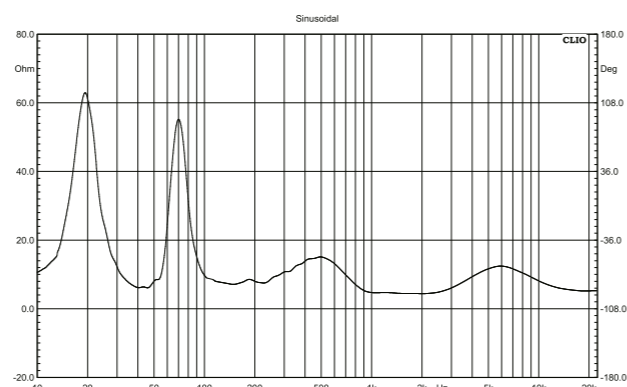
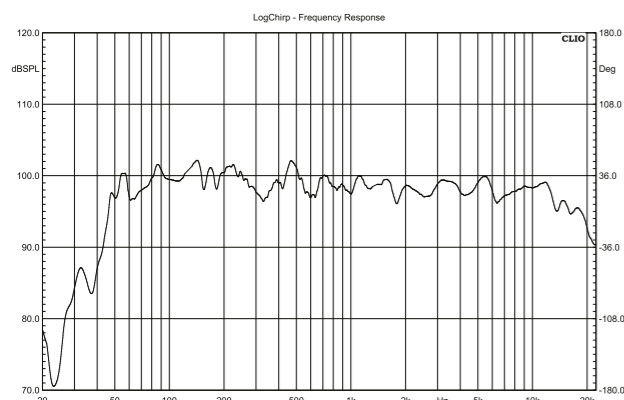

Reason-X18B

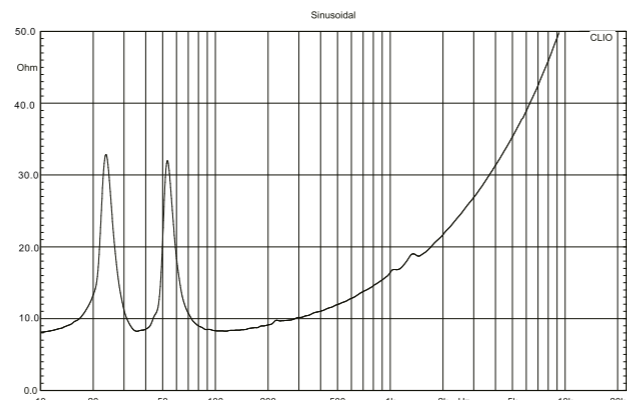
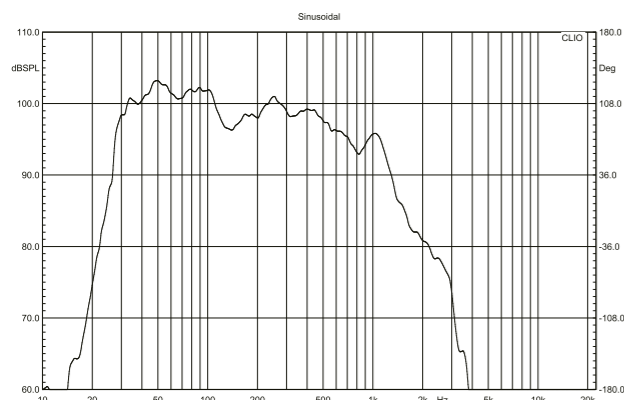

Reason-X218B

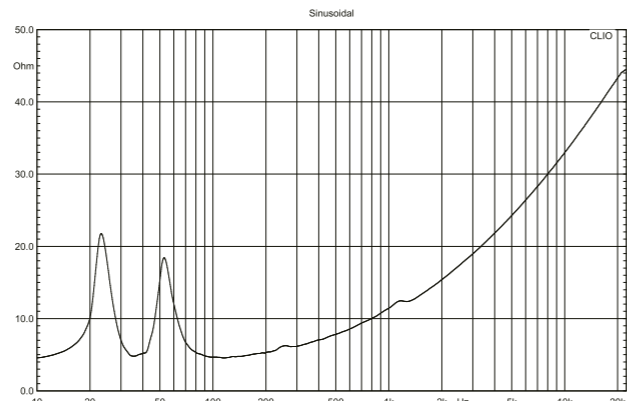
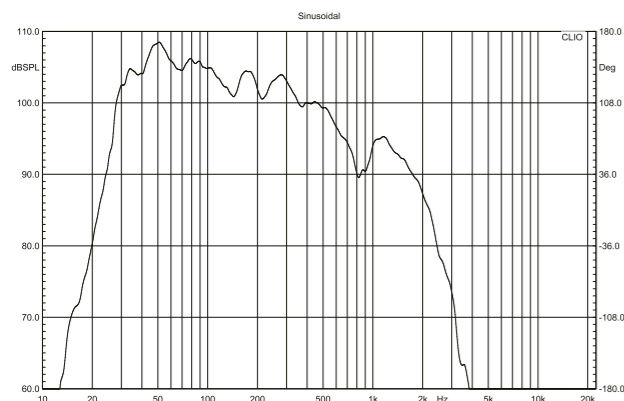

SPECIFICATIONS

Model Name	Reason-X12	Reason-X15	Reason-X18B	Reason-X218B
System Type	Passive	Passive	Passive	Passive
Configuration	Three-way	Three-way	Single Subwoofer	Dual Subwoofer
Frequency Response (+/-3 dB)	55-20 kHz	45-20 kHz	35-1 kHz	30-1 kHz
Frequency Range (-10 dB)	50-20 kHz	40-20 kHz	30-800 HZ	25-800 HZ
Sensitivity 2.83 V / 1 Meter	98 dB	99 dB	103 dB	109 dB
Calculated Maximum SPL @1 Meter	131 dB	133 dB	139 dB	148 dB
System Rated Impedance	8 Ω	8 Ω	8 Ω	4 Ω
<b>Low Frequency Transducer</b>				
Size	332 mm / 12"	404 mm / 15"	470 mm / 18"	470 mm / 18"
Voice Coil Size	75 mm / 3.0"	75 mm / 3.0"	102 mm / 4"	102 mm / 4"
LF Magnet Material	ferrite	ferrite	ferrite	ferrite
LF Frame Material	Aluminium	Aluminium	Aluminium	Aluminium
Rated Impedance	8 Ω	8 Ω	8 Ω	2 x 8 Ω
LF Power re:AES2-2012	400 W	500 W	1000 W	2 x 1000 W
<b>Mid Frequency Transducer</b>				
Size	203.8 mm / 8"	203.8 mm / 8"		
Voice Coil Size	50.8 mm / 2.0"	50.8 mm / 2.0"		
MF Magnet Material	ferrite	ferrite		
MF Frame Material	Aluminium	Aluminium		
Rated Impedance	8 Ω	8 Ω		
MF Power re:AES2-2012	100 W	100 W		
<b>High Frequency Transducer</b>				
HF Driver Type	Compression Driver	Compression Driver		
Coil Size (mm / inches)	38 mm / 1.5"	38 mm / 1.5"		
Exit Size (mm / inches)	25 mm / 1"	25 mm / 1"		
HF Magnet Material	NdFeB	NdFeB		
Diaphragm Material	PEN	PEN		
Rated Impedance	8 Ω	8 Ω		
HF Power re:AES2-2012	40 W	40 W		
Waveguide Type	square	square		
Nominal Coverage (H x V)	100 x 70	100 x 70		
Nominal Impedance	8 Ω	8 Ω		
<b>Power</b>				
System AES (RMS) Power (W)	500 W	600 W	1000 W	2000 W
System Programme Power (W)	1000 W	1200 W	2000 W	4000 W
System Peak Power (W)	2000 W	2400 W	4000 W	8000 W
Crossover Frequency	800 Hz / 2.7 kHz	800 Hz / 2.7 kHz		
Input Connector	2 x speakON compatible	2 x speakON compatible	2 x speakON compatible	2 x speakON compatible
Rigging	M8 x 12	M8 x 12	No	No
Handles	2 on Sides	2 on Sides	2 on Sides	4 on Sides
<b>Enclosure</b>				
	35 mm pole socket			
Cabinet Type	Trapezoid	Trapezoid	square	square
Enclosure Material and finish	15 mm plywood	15 mm plywood	18 mm plywood	18 mm plywood
Colour Options	Black paint	Black paint	Black paint	Black paint
Grille Material & Finish	Steel	Steel	Steel	Steel
<b>Dimensions - Unpacked (mm / inches)</b>				
Height	814 mm / 32.0"	883 mm / 34.8"	600 mm / 23.6"	560 mm / 22.0"
Width Front	350 mm / 13.8"	430 mm / 16.9"	560 mm / 22.0"	1065 mm / 41.9"
Width Rear	231 mm / 9.1"	298 mm / 11.7"	560 mm / 22.0"	1065 mm / 41.9"
Depth	410 mm / 16.1"	455 mm / 17.9"	756 mm / 29.8"	756 mm / 29.8"
<b>Dimensions - Packed (mm / inches)</b>				
Height	909 mm / 35.8"	978 mm / 38.5"	670 mm / 26.4"	668 mm / 26.3"
Width Front	500 mm / 19.7"	545 mm / 21.5"	829 mm / 32.6"	1138 mm / 44.8"
Width Rear	500 mm / 19.7"	545 mm / 21.5"	829 mm / 32.6"	1138 mm / 44.8"
Depth	440 mm / 17.3"	520 mm / 20.5"	633 mm / 24.9"	829 mm / 32.6"
<b>Weight</b>				
Net Weight	29.0 kg / 63.8 lbs	32.5 kg / 71.5 lbs	45.5 kg / 100.1 lbs	73.8 kg / 162.4 lbs
Gross Weight	33.7 kg / 74.2 lbs	37.5 kg / 82.5 lbs	55.2 kg / 121.4 lbs	87.7 kg / 192.9 lbs



# FOCUS Series

OUR FLAGSHIP POINT-SOURCE ARRAY FOR PORTABLE RENTALS, TOURING AND FIXED STAGE



## Optimised acoustic engineering

The Focus family has 5 components to choose from - a 12" and 15" PA and an 18" and twin 18" subwoofer plus the new Focus-12M floor monitor.

Focus tops and subs are superbly engineered to work together seamlessly and provide maximum efficiency. The two-way PA speakers employ a High-Q 100° x 10° long-throw waveguide horn geometry to project the sound all the way to the back of large listening areas. All this comes together to create a powerful point-source array system.

## Meets your needs

Focus hardware allows you to fly in a line-array configuration, fly independently and in pairs or stack PA's on top of subs. Focus adapts perfectly to whatever challenges your venue presents you with.

- Flexible point-source passive array series
- 100° x 10° long-throw waveguides
- Huge power handling up to 2800 W Peak
- Huge SPL capabilities up to 146 dB SPL peak
- Bi-amp and Passive modes
- Dual angle pole mount sockets
- NL4 (speakON compatible) inputs
- Fly individually, in pairs or in array formations
- HF compression drivers with 3.2" voice coils
- 15 mm Russian birch plywood construction.
- M10 x 11 & Fly Track Rigging points

## SPECIFICATIONS

## Passive PA Speakers



Model Name	Focus-12	Focus-15	Focus-12M	Focus-18S	Focus-218S
System Type	Passive	Passive	Passive	Passive	Passive
Configuration	Two-way	Two-way	Two-way floor monitor	Subwoofer	Dual Subwoofer
Frequency Response (+/-3 dB)	60 Hz - 20 kHz	50 Hz - 20 kHz	60 Hz - 20 kHz	35 Hz - 800 Hz	30 Hz - 800 Hz
Frequency Range (-10 dB)	55 Hz - 20 kHz	45 Hz - 20 kHz	65 Hz - 20 kHz	30 Hz - 800 Hz	25 Hz - 800 Hz
Sensitivity (2.83 v / 1 m)	99.5 dB	99.5 dB	99 dB	104 dB	107 dB
Calculated Maximum SPL @1 m	133 dB	135 dB	132 dB	140 dB	146 dB
System Rated Impedance	8 Ω	8 Ω	8 Ω	8 Ω	Parallel 4 Ω / Discrete 2 x 8 Ω
<b>Low Frequency Transducer</b>					
Size	331 mm / 12"	390 mm / 15"	305 mm / 12"	462 mm / 18"	462 mm / 18"
Voice Coil Size	76.2 mm / 3"	102 mm / 4"	75 mm / 3.0"	114.3 mm / 4.5"	114.3 mm / 4.5"
Rated Impedance	8 Ω	8 Ω	8 Ω	8 Ω	2 x 8 Ω
LF Power (re:AES2-2012)	500 w	700 w	500 w	1000 w	2 x 1000 w
<b>High Frequency Transducer</b>					
HF Driver Type	Compression Driver	Compression Driver	Compression driver	-	-
Voice Coil Size	81 mm / 3.2"	81 mm / 3.2"	50.8 mm / 2"	-	-
Exit Size	35.5 mm / 1.3"	35.5 mm / 1.3"	35.6 mm / 1.4"	-	-
Diaphragm Material	Titanium	Titanium	Titanium	-	-
Rated Impedance	8 Ω	8 Ω	8 Ω	-	-
HF Power (re:AES2-2012)	75 w	75 w	50 w	-	-
Nominal Coverage (H x V)	100° x 10°	100° x 10°	90° x 40°	-	-
<b>Power</b>					
System Continuous Power	500 w	700 w	500 w	1000 w	Parallel 2000 w / Discrete 1000 w
System Programme Power	1000 w	1400 w	1000 w	2000 w	Parallel 4000 w / Discrete 2000 w
System Peak Power	2000 w	2800 w	2000 w	4000 w	Parallel 8000 w / Discrete 4000 w
Crossover frequency	1.6 kHz	1.6 kHz	2.0 kHz	-	-
Input Connector	2 x NL4 (speakON Compatible)	2 x NL4 (speakON Compatible)	2 x NL4 (speakON Compatible)	2 x NL4 (speakON Compatible)	2 x NL4 (speakON Compatible)
<b>Hardware</b>					
Pole Mount	Dual-angle 35 mm Pole Socket	Dual-angle 35 mm Pole Socket	35 mm pole socket	M20 thread Pole Mount	M20 thread Pole Mount
Handles	2 On Sides	2 On Sides	1 on top	4 On Sides	4 On Sides
<b>Enclosure</b>					
Enclosure Material	15 mm Plywood	15 mm Plywood	15 mm Plywood	18 mm Plywood	18 mm Plywood
Finish	Black Rhino Paint	Black Rhino Paint	Black Rhino Paint	Black Rhino Paint	Black Rhino Paint
Grille Material & Finish	1.5 mm Steel	1.5 mm Steel	1.5 mm Steel	1.5 mm Steel	1.5 mm Steel
<b>Dimensions - (Unpacked)</b>					
Height	625 mm / 24.6"	690 mm / 27.17"	570 mm / 22.4"	540 mm / 21.26"	540 mm / 21.26"
Width Front	455 mm / 17.91"	455 mm / 17.91"	374.6 mm / 14.7"	490 mm / 19.29"	880 mm / 34.65"
Width Rear	270 mm / 10.63"	224.5 mm / 8.84"	374.6 mm / 14.7"	490 mm / 19.29"	880 mm / 34.65"
Depth	435 mm / 17.13"	433 mm / 17.05"	331.5 mm / 13.05"	900 mm / 35.43"	900 mm / 35.43"
<b>Dimensions - (Packed)</b>					
Height	695 mm / 27.36"	750 mm / 29.53"	665 mm / 26.2"	615 mm / 24.21"	615 mm / 24.21"
Width Front	455 mm / 17.91"	500 mm / 19.69"	454 mm / 18.5"	560 mm / 22.05"	960 mm / 37.80"
Width Rear	270 mm / 10.63"	285 mm / 7.28"	454 mm / 18.5"	560 mm / 22.05"	960 mm / 37.80"
Depth	426 mm / 16.78"	480 mm / 18.9"	401 mm / 15.8"	970 mm / 38.19"	970 mm / 38.19"
<b>Weight</b>					
Net Weight	26.3 kg / 57.9 lbs	34.1 kg / 75 lbs	21.4 kg / 47.1 lbs	52.4 kg / 115.3 lbs	86.5 kg / 190.3 lbs
Gross Weight	28.2 kg / 62.04 lbs	36.5 kg / 80.3 lbs	23.8 kg / 52.4 lbs	61.3 kg / 134.9 lbs	98 kg / 215.6 lbs



# IPX6 RATED ARRAYS

WATERPROOF IPX6 CERTIFIED LINE ARRAY SYSTEMS



**NEW**



Introducing new WLA series line array models which overcome nature and give total peace of mind for outdoor installations and events! The all new F version (waterproof) series.

With the same reliability and high performance characteristics as the original 'non-F' models, these F models are IPX6 Certified. This certification states that there should be no harmful effects when "Water is projected in powerful jets (12.5 mm nozzle) against the enclosure from any direction"

With rust-proof aluminium grilles, components wrapped in wax and anti-corrosion stainless and aluminium screws and hardware, the F models are made for the rain and long-term environmental exposure.

In addition, to reduce any risk of standing water, and to help rental companies with storage, the front grille has been flattened.

## FEATURES

- Stainless steel hardware (WLA-28F system)
- Aluminium hardware (WLA-210XF system)
- Wax wrapped components and flat aluminium front grilles
- Waterproof connectors
- Stainless Common Fly Frames for flying or ground stacking

### WLA-210XF

- Dual 10" line array element
- Dual waterproof connectors



### WLA-210XSUBF

- Dual 15" line array subwoofer
- Single waterproof connector



### WLA-218BF

- Dual 18" subwoofer
- Single waterproof connector



### WLA-28F

- Dual 8" line array element
- Dual waterproof connectors



### WLA-28SUBF

- Dual 15" subwoofer
- Single connector



### WLA-15MF

- 15" floor monitor
- Single waterproof connector

# IPX6 ARRAYS

WATERPROOF IPX6 CERTIFIED LINE ARRAY SYSTEMS

Line Array



Model Name	WLA-210XF	WLA-210XSUBF	WLA-28F	WLA-28SUBF	WLA-218BF	WLA-15MF
System Type	IPX6 waterproof	IPX6 waterproof	IPX6 waterproof	IPX6 waterproof	IPX6 waterproof	IPX6 waterproof
Configuration	Two-way 2 x 10"	2 x 15" subwoofer	Two-way 2 x 8"	2 x 15" subwoofer	2 x 18" subwoofer	15" monitor
Freq Response (+/-3 dB)	65 Hz - 20 kHz	39 Hz - 900 Hz	65 Hz - 20 kHz	39 Hz - 900 Hz	30 Hz - 800 Hz	50 Hz - 20 kHz
Freq Range (-10 dB)	60 Hz - 20 kHz	35 Hz - 1.5 kHz	60 Hz - 20 kHz	35 Hz - 1.5 kHz	25 Hz - 1 KHz	45 Hz - 20 kHz
Sensitivity (2.83 v / 1 m)	102 dB	108 dB	101 dB	108 dB	109 dB	99 dB
Calc Max SPL @1 m	138 dB	145 dB	133 dB	145 dB	148 dB	133 dB
System Impedance	16 Ω	4 Ω	16 Ω	4 Ω	4 Ω	8 Ω
<b>LF Transducer</b>						
Size	2 x 260 mm / 2 x 10"	2 x 381 mm / 15"	2 x 203.2 mm / 2 x 8"	2 x 381 mm / 15"	2 x 470 mm / 18"	381 mm / 15"
Voice Coil Size	65 mm / 2.5"	100 mm / 4.0"	51.6 mm / 2.0"	100 mm / 4.0"	102 mm / 4.0"	102 mm / 4.0"
Rated Impedance	2 x 8 Ω	2 x 8 Ω	2 x 8 Ω	2 x 8 Ω	2 x 8 Ω	8 Ω
LF Power (re:AES2-2012)	2 x 400 W	2 x 600 W	2 x 200 W	2 x 600 W	2 x 1000 W	700 W
<b>HF Transducer</b>						
Compression driver	Neo	-	Ferrite	-	-	Neo
Voice Coil Size	75 mm / 3.0"	-	75 mm / 3.0"	-	-	82 mm / 3.2"
Exit Size	35.6 mm / 1.4"	-	35.6 mm / 1.4"	-	-	35.6 mm / 1.4"
Diaphragm Material	Titanium	-	Titanium	-	-	Titanium
Rated Impedance	8 Ω	-	16 Ω	-	-	8 Ω
HF (re:AES2-2012)	90 W	-	90 W	-	-	80 W
Coverage (H x V)	100° x 10°	-	100° x 10°	-	-	90° x 60°
<b>Power</b>						
Continuous Power	LF:800 W HF:90 W	1200 W	LF:400 W HF: 90 W	1200 W	2000 W	700 W
Programme Power	LF:1600 W HF:180 W	2400 W	LF:800 W HF:180 W	2400 W	4000 W	1400 W
Peak Power	LF:3200 W HF:360 W	4800 W	LF:1600 W HF:360 W	4800 W	8000 W	2800 W
Crossover frequency	1.5 kHz	No	1.7 kHz	No	No	No
Operational Modes:	No	No	No	No	No	No
Input Connector	2 x waterproof	1 x waterproof	2 x waterproof	1 x waterproof	1 x waterproof	1 x waterproof
<b>Hardware</b>						
	Integral - adjustable rigging 0°-10°	Integral non adjustable	Integral - adjustable rigging 0°-10°	Integral non adjustable		35 mm pole socket
Enclosure Material	15 mm, 18 mm Ply	15 mm, 18 mm Ply	15 mm, 18 mm Ply	18 mm Plywood	18 mm Plywood	15 mm Plywood
Finish	Waterproof Paint	Waterproof Paint	Waterproof Paint	Waterproof Paint	Waterproof Paint	Waterproof Paint
Grille Material	3.0 mm Aluminium	3.0 mm Aluminium	1.5 mm Aluminium	3.0 mm Aluminium	3.0 mm Aluminium	3.0 mm Aluminium
<b>Dims- (Unpacked)</b>						
Height Front	333.3 mm / 13.1"	494 mm / 19.4"	250 mm / 9.84"	485 mm / 19.1"	560 mm / 22.0"	723 mm / 28.5"
Height Rear	256.3 mm / 10.0"	494 mm / 19.4"	188 mm / 7.4"	485 mm / 19.1"	560 mm / 22.0"	723 mm / 28.5"
Width	845 mm / 33.3"	845 mm / 33.3"	760 mm / 29.92"	760 mm / 29.9"	1065 mm / 41.9"	432 mm / 17.0"
Depth	443 mm / 17.4"	653 mm / 25.7"	463.2 mm / 18.23"	716 mm / 28.2"	756 mm / 29.8"	395.6 mm / 73.3"
<b>Dims - (Packed)</b>						
Height	953 mm / 37.5"	933 mm / 36.7"	320 mm / 12.6"	575 mm / 22.6"	638 mm / 25.1"	826 mm / 32.5"
Width Front	424 mm / 16.7"	723 mm / 28.5"	830 mm / 32.7"	850 mm / 33.5"	1138 mm / 44.8"	522 mm / 20.6"
Width Rear	424 mm / 16.7"	723 mm / 28.5"	830 mm / 32.7"	850 mm / 33.5"	1138 mm / 44.8"	522 mm / 20.6"
Depth	513 mm / 20.2"	584 mm / 23.0"	534 mm / 21.0"	806 mm / 31.7"	829 mm / 32.6"	490 mm / 19.3"
<b>Weight</b>						
Net Weight	46.0 kg / 101.2 lbs	81.0 kg / 178.2 lbs	28.5 kg / 63.8 lbs	62.2 kg / 134.6 lbs	72.8 kg / 160.5 lbs	30.5 kg / 67.1 lbs
Gross Weight	50.0 kg / 110.0 lbs	86.4 kg / 190.1 lbs	31.0 kg / 69.3 lbs	70.2 kg / 145.2 lbs	87.1 kg / 192 lbs	35.6 kg / 78.32 lbs



# WLA-312X System

## THREE-WAY LINE ARRAY

**NEW**



WLA-312X is an advanced three-way line array speaker system capable of handling vast amounts of power - while remaining sonically clear, precise and accurate. Rated at 1410 watts AES (RMS) per cabinet and boasting highly efficient custom Wharfedale Pro drivers, the WLA-312X can deliver an astonishing 138 dB Max SPL @ 1 meter.

Custom WP drivers have been selected to ensure that this series not only has the power you would expect, but the three-way configuration brings a new sonic dimension and definition.

With dual 12" woofers, a single 10" midrange driver and dual 2.55" compression drivers, the WLA-312X has everything needed for large venue coverage. In addition, there is no need to fly subwoofers within the array - the WLA-312X has already got plenty of low-end punch.

The WLA-312X is designed to be controlled and tuned with either a Wharfedale Pro Versadrive signal processor or a DP-D series amplifier. Either of these DSP systems deliver full signal routing and processing to maximise the power and sonic effect of the WLA-312X array.

With full steel grilles, multiple handles and 3 fly frame rigging points, WLA-312X is well suited for touring and for hard work on the road.

The accompanying WLA-312X Fly frame is solid! Constructed of A3 steel it can hold up to 900 kg (that's up to 12 pcs of WLA-312X) with a safety factor of 12.

## FEATURES

- Three-way line array element
- 2 x 12" LF drivers
- 1 x 10" Neo Midrange driver
- 2 x 2.55" Neo HF compression drivers
- Birch plywood construction
- 1410 watts AES (RMS)
- 2820 watts Programme
- 5640 watts Peak
- 16 ohms impedance
- Fly frame to support up to 12 elements (900 kg)

## 3-way

With dedicated components for each of the main bandwidths, 3-way systems bring enhanced frequency definition to the listening experience.

3-way systems bring a clarity and space that can only be experienced.

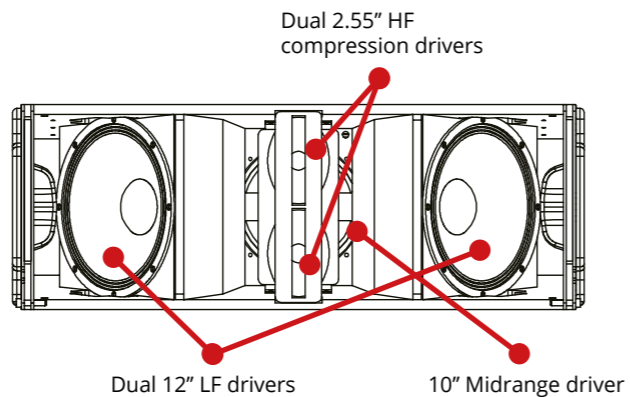

## WIRING DIAGRAM

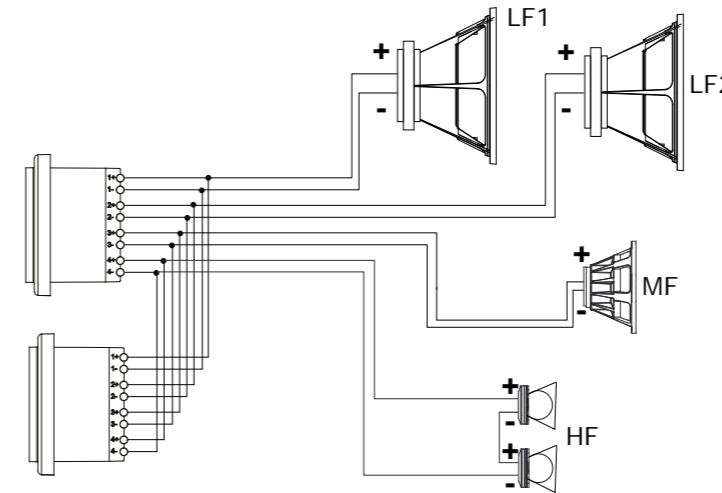

## Go large

Any 3-way system needs tuning and DSP power.

The allocation of power and frequencies needs to be controlled to maximise the system output.

For this, DP-D series amplifiers are highly recommended. Huge power output and with comprehensive internal Digital Signal Processing, DP-D series amps are the perfect driving partner for the WLA-312X.

Such power and control allows for massive systems to be configured.

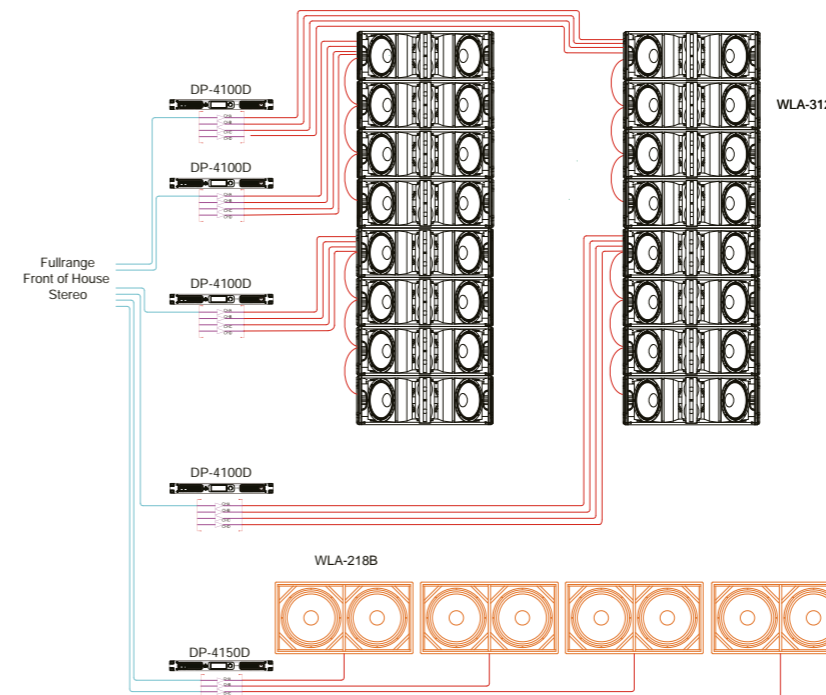

## Line Array

<b>Model Name</b>	WLA-312X
<b>System Type</b>	Passive
<b>Configuration</b>	three-way
<b>Frequency Response (+/-3 dB)</b>	50-18 kHz
<b>Frequency Range (-10 dB)</b>	40-20 kHz
<b>Sensitivity 2.83 v / 1 Meter</b>	HF:114 dB/MF:105 dB/LF:102 dB
<b>Calculated Maximum SPL @ 1 Meter</b>	HF:142 dB/MF:136 dB/LF:138 dB
<b>Low Frequency Transducer</b>	
<b>Size (mm / inches)</b>	313 mm / 12"
<b>Voice Coil Size (mm / inches)</b>	75.5 mm / 3"
<b>LF Magnet Material</b>	Ferrite
<b>LF Frame Material</b>	Aluminium
<b>Rated Impedance</b>	2 x 8 Ω
<b>LF Power re: AES2-2012</b>	2 x 450 W
<b>Mid Frequency Transducer</b>	
<b>Size (mm / inches)</b>	260 mm / 10"
<b>Voice Coil Size (mm / inches)</b>	65 mm / 2.55"
<b>MF Magnet Material</b>	NdFeB
<b>MF Frame Material</b>	Aluminium
<b>Rated Impedance</b>	16 Ω
<b>MF Power re: AES2-2012</b>	350 W
<b>High Frequency Transducer</b>	
<b>HF Driver Type</b>	Compression Driver
<b>Coil Size (mm / inches)</b>	65 mm / 2.55"
<b>Exit Size (mm / inches)</b>	1.4"
<b>HF Magnet Material</b>	NdFeB
<b>Diaphragm Material</b>	Titanium
<b>Rated Impedance</b>	16 Ω (2 x 8 Ω)
<b>HF Power re: AES2-2012</b>	160 W (2 x 80 W)
<b>Waveguide Type</b>	square
<b>Nominal Coverage (H x V)</b>	90H x 7.5V
<b>Nominal Impedance</b>	16 Ω
<b>Power</b>	
<b>System Power AES (RMS) (w)</b>	HF:160 W/MF:350 W/LF:900 W
<b>System Programme Power (w)</b>	HF:320 W/MF:700 W/LF:1800 W
<b>System Peak Power (w)</b>	HF:640 W/MF:1400 W/LF:3600 W
<b>Crossover frequency</b>	160 Hz / 1.2 kHz
<b>Input Connector</b>	2 x Neutrik NL8MPR
<b>Rigging</b>	3 points for rigging
<b>Pole mount</b>	NO
<b>Handles</b>	Yes
<b>Enclosure</b>	
<b>Cabinet type</b>	Trapezoid
<b>Enclosure Material and finish</b>	15 mm, 18 mm plywood
<b>Colour Options</b>	black paint
<b>Grille Material &amp; Finish</b>	steel
<b>Dimensions - Unpacked</b>	
<b>Height</b>	370 mm
<b>Width Front</b>	1030 mm
<b>Width Rear</b>	279 mm
<b>Depth</b>	550 mm
<b>Dimensions - Packed</b>	
<b>Height</b>	1095 mm
<b>Width Front</b>	480 mm
<b>Width Rear</b>	480 mm
<b>Depth</b>	650 mm
<b>Weight</b>	
<b>Net Weight</b>	58 kg
<b>Gross Weight</b>	62 kg



# WLA-210X System

OUR ALL-NEW DUAL 10" LINE ARRAY SYSTEM.

The new WLA-210X line array system keeps the same design philosophies as the acclaimed WLA-25 and WLA-28 systems from Wharfedale Pro.

Portable, powerful and versatile line array solutions which are ideal for both touring and fixed installation applications.

Each WLA-210X element uses a pair of custom 10" Wharfedale Pro high-power low-frequency drivers, while the high frequencies are handled by a premium 3.0" titanium diaphragm, neodymium magnet compression driver coupled to a 100° x 10° waveguide.

The waveguide exit extends nearly to the top and bottom of the enclosure to create a continuous acoustical source - resulting in greatly reduced destructive interaction within the array.



## Bi-amp and Passive modes

A switch on the WLA-210X input panel selects between either of two operating modes: Passive mode (single amplifier) or Bi-amp mode (separate low and high frequency amplifiers).

In Passive mode, the internal crossovers of the WLA-210X loudspeakers divide the audio signal into the separate frequency ranges for each driver. In Bi-amp mode separate (discrete) amplifiers can be used to power the low frequency and high frequency drivers.

The Versadrive series are ideal for passive & bi-amp mode operation and control.

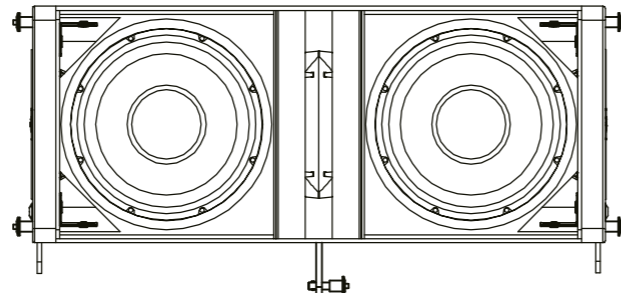

## WLA-210X

- 2 x 10" LF drivers with 2.5" voice coils
- 1 x Neodymium HF compression driver with 3" voice coil
- 16 Ω Impedance
- Passive and Bi-amp operation modes
- 100° x 10° dispersion
- HF : 90 w AES (RMS) / 180 w Programme / 360 w Peak
- LF : 800 w AES (RMS) / 1600 w Programme / 3200 w Peak
- Internal rigging system
- 15 mm / 18 mm plywood construction
- Max SPL @1 m (Passive mode) 138 dB



## WLA-210XSUB

- Dual 15" passive subwoofer
- 4.0" Voice coils
- Max SPL @ 1 meter 145 dB
- 1200 w AES (RMS) / 2400 w Programme / 4800 w Peak
- 4 Ω Impedance
- 18 mm plywood construction

## WLA-210X Common Fly Frame

Arrays can be assembled using up to 12 x WLA-210X line array elements or with WLA-210XSUB Subwoofers at the top of the array with a safety factor of 12.

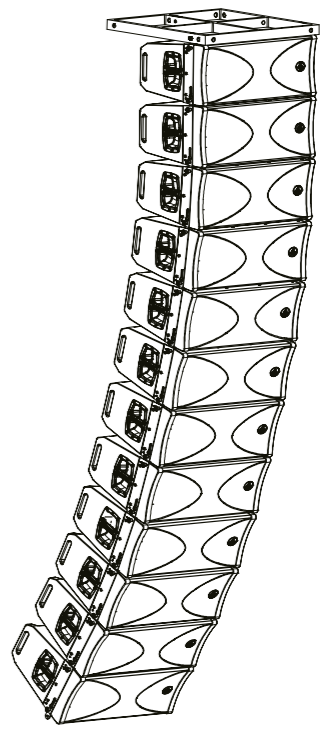
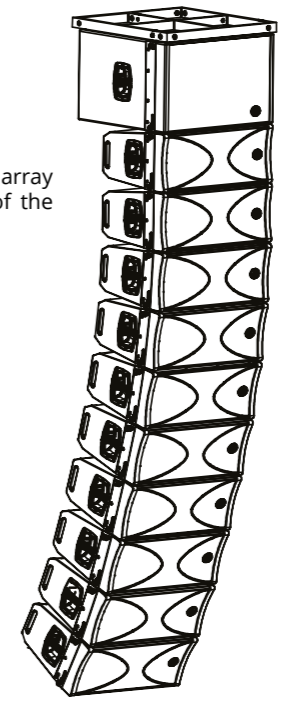
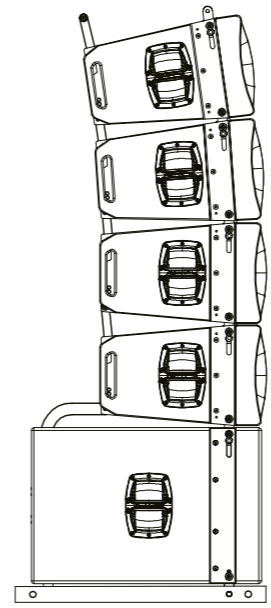

## Optimised Ground Stacking

WLA-210X rigging doubles up as an optimised ground stacking system, using the WLA-210XSUB subwoofer as a base.

Arrays of WLA-210X line array elements can be aimed downwards by as much as 10° to cover audience areas close to a stage, as well as upward by as much as 10° in order to better cover distant balcony seating areas.



# WLA-28 System

DESIGNED FROM THE GROUND UP BY OUR VETERAN LOUDSPEAKER TEAMS FROM THE UK AND USA.



WLA-15B



WLA-28



## Huge sound pressure level

The WLA-28 uses a pair of high powered 8" LF drivers and a 3.2" neodymium HF driver to generate an impressive 132 dB max SPL while handling up to 1600 watts peak.



## Bi-amp and Passive modes

On the rear of the WLA-28 is the Bi-amp and Passive mode switch. This allows for versatile and controllable configurations where separate amps can be selected to drive the HF and LF components individually.

## WLA-28 / WLA-15B

The WLA-28 has been developed to condense the extreme SPL and long-throw capabilities of larger line array systems in to a compact 2 x 8" configuration. It is accompanied by the WLA-15B and the new WLA-28SUB which are matched to extend the low frequencies for a complete, full-range system.

## Extend Your Bass

Two subwoofer systems are available to add the low end to a WLA-28 rig.

The WLA-15B single 15" sub reaches depths of 35 Hz and has an output potential of 2800 watts peak.

The dual 15" WLA-28SUB delivers 145 dB with a peak power handling of 4800 watts. Both subwoofers feature massive 4" voice coils for extreme power handling.



WLA-28SUB

## Line Array



## Ready for Rigging

A versatile captive, hidden rigging system allows for fast setup, with the widest range of splay angles, while keeping the toughened steel brackets hidden within the chassis. Inter element splay angles guarantee that a WLA system can meet the needs of your venue.

## WLA-28 FLY FRAME

The WLA-28 Fly Frame is specifically designed for the WLA-28 and WLA-15B. This frame is the easiest and safest way to rig a WLA system and is capable of rigging a total of 8 x WLA-28 and 1 x WLA-15B, or 12 x WLA-28. Combined with the advanced locking-pin and adjustable angle of the WLA-28 pa speaker, the system as a whole ensures a loud projection of sound, directly at your audience.

WLA-28SUB Fly Frame is used with systems containing a WLA-28SUB.

Ground stack or fly the WLA-28SUB frame supports up to 8 x WLA-28 and 1 x WLA-28SUB with a safety factor of 12.

- High Sensitivity, Full Horn Loaded Design
- Constant directivity waveguides
- Rare Earth Magnets
- Physically Aligned Transducers
- 2 x parallel NL4 (speakON compatible) inputs

- Comprehensive Adjustable Splay Angles
- Durable Rhino Rock finished cabinets
- Front Hinged Rigging System
- Captive Rigging Hardware
- Tethered Quick Release Pins (Each Rated To 2000 Kg)



# WLA-25 System

COMPACT POWER WITH SONIC DETAIL.



WLA-25 is a two-way passive line array system which features the same design philosophy as its established larger brother, the WLA-28.

It brings long throw capabilities together with extreme SPL - all from within a compact and portable array system.



WLA-25



WLA-25SUB

The biggest breakthrough during the development process was the creation of a custom Wharfedale Pro neodymium HF compression driver. This newly engineered HF component delivers extreme sensitivity from a very compact and lightweight design. Along with its supersensitive 1.75" voice coil, this HF compression driver also features aluminium back plating which acts as a heat sink to aid heat dissipation. This attention to detail protects the driver from heat damage and mechanical distortion during extreme performance levels.

The 2 x 5" custom LF drivers have been developed to work in partnership with this neo HF driver. Rigid die cast baskets ensure consistent sonic performance with minimum distortion. The placement and physical mounting of all the drivers have been fine tuned to ensure maximum phase coherence and SPL are achieved from the compact cabinet.

The specially designed acoustic grilles in front of the 5" woofers optimise the midrange directivity while the HF exponential

horn delivers consistent HF accuracy and detail. In addition, the trapezoidal enclosure has been developed to reduce any acoustic sidelobes within the array.

For low-end punch we have also created the 141 dB SPL WLA-25SUB subwoofer. This subwoofer physically and acoustically matches the WLA-25 system. Using a reversed-phase horn loaded design, the 2 \* 10" LF drivers with massive 2.5" coils deliver the consistent low end punch to complete this versatile array.

The hardware design allows the system to be groundstacked or it can be flown using the matching WLA-25 Flyframe or WLA-25SUB Flyframe.

Available in a black or white Rhino Rock covering, the compact WLA-25 and WLA-25SUB is a perfect system for multi-function halls, theatres, and houses of worship.

## Line Array

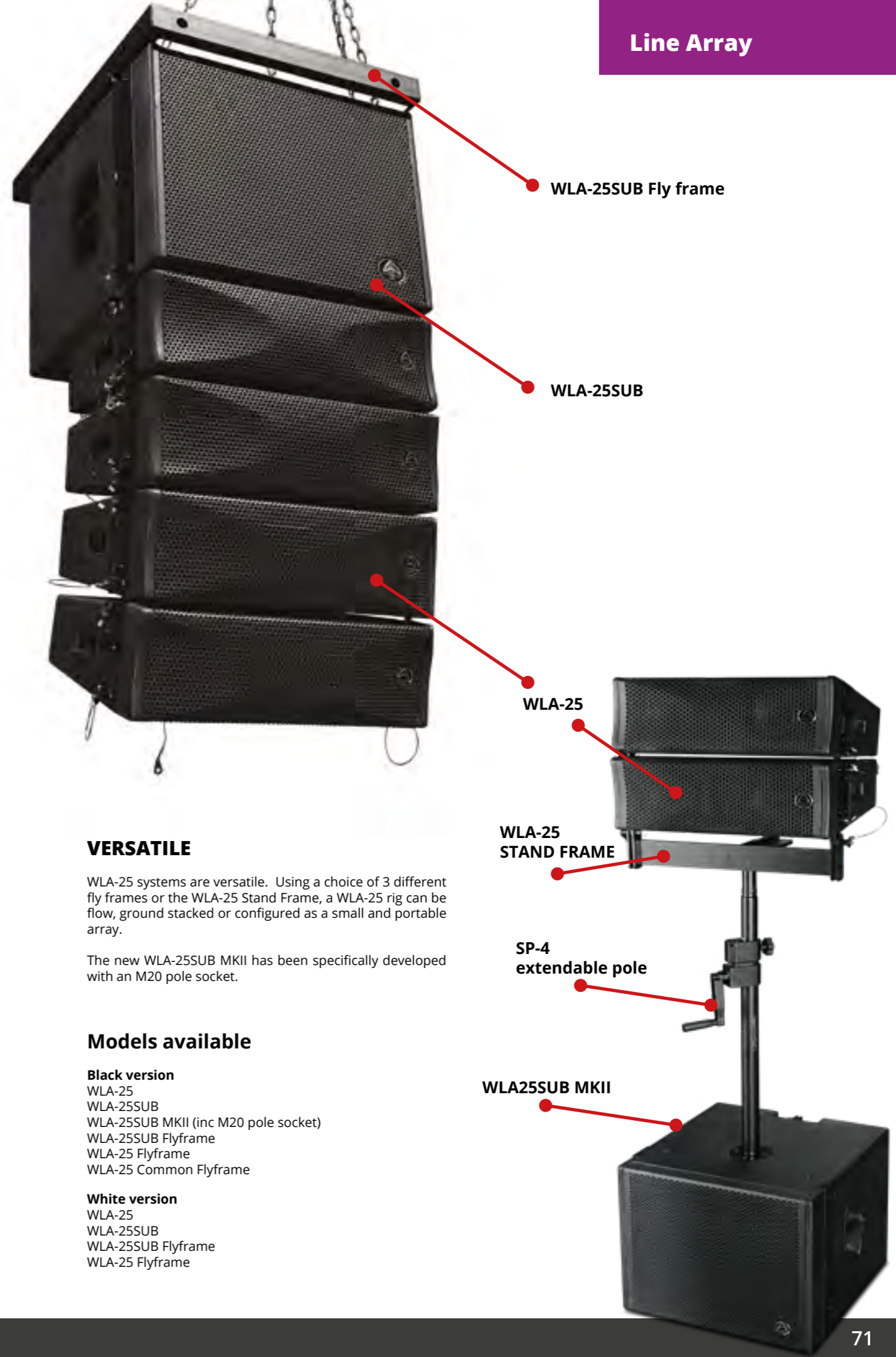

WLA-25SUB Fly frame

WLA-25SUB

WLA-25

WLA-25 STAND FRAME

SP-4 extendable pole

WLA25SUB MKII

### VERSATILE

WLA-25 systems are versatile. Using a choice of 3 different fly frames or the WLA-25 Stand Frame, a WLA-25 rig can be flown, ground stacked or configured as a small and portable array.

The new WLA-25SUB MKII has been specifically developed with an M20 pole socket.

### Models available

- Black version**  
WLA-25  
WLA-25SUB  
WLA-25SUB MKII (inc M20 pole socket)  
WLA-25SUB Flyframe  
WLA-25 Flyframe  
WLA-25 Common Flyframe

- White version**  
WLA-25  
WLA-25SUB  
WLA-25SUB Flyframe  
WLA-25 Flyframe



# WLA ground level subs

# WLA monitors



## WLA-218SUB

Using a dual chamber cabinet, WLA-218SUB delivers huge bass in a versatile configuration. 2x18" LF transducers with massive 4" voice coils produce up to 138 dB SPL - while their cast frame aluminium baskets reduce any risk of mechanical distortion.



A unique feature to WLA-218SUB is the Parallel and Discrete switch. This allows for single 4 Ω or dual amplified 8 Ω operation and connectivity.

- 1600 w AES (RMS) / 3200 w Programme / 6400 w Peak
- Dual chamber enclosure allowing for use of single or dual amplifier channels
- Dual 18" cast frames Long throw 4" voice coil woofers
- Strong internal bracing prevents bass loss and distortion from enclosure vibration & resonance

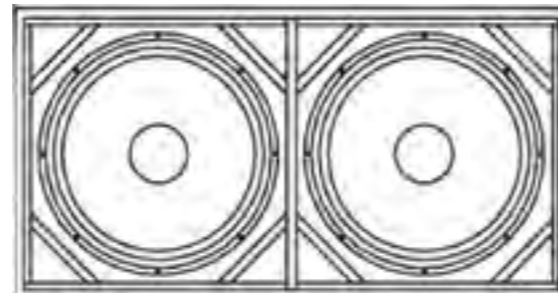

- 4 Ω parallel, single channel or discrete 8 Ω dual channel configuration
- Black rhino paint to match with WLA-28 paint finish
- 18 mm Birch plywood construction

## WLA-218B

The WLA-218B is for those moments when you need more than just bass. You need sub-bass, you need punch, impact - and you need that sheer, breath-taking bottom-end power.

This massive subwoofer is designed for ground placement. The two 18" Wharfedale Pro LF transducers with massive 4" voice coils work together to deliver up to 148 dB Max SPL. Using cast frame aluminium baskets, any mechanical distortion is dramatically reduced ensuring smooth, accurate and honest reproduction.

- 2000 w AES (RMS) / 4000 w Programme / 8000 w Peak power
- Dual 18" cast frames
- Long throw 4" voice coil woofers
- 2 x Parallel speakON compatible inputs



- Black rhino paint finish
- Strong internal bracing prevents bass loss and distortion from enclosure vibration and resonance
- 18 mm Birch plywood construction



Top and side NL4MP connectors  
15 mm birch plywood cabinet



- 3.2" Neo compression drivers with high flux density
- Rotatable horns for H or V applications
- 4 x Neutrik NL4MP connectors on top/side/rear
- Aluminium ring in LF transducer to reduce distortion
- Polygon design

Model Name	WLA-12M	WLA-15M
Configuration	2-way 12" passive floor monitor	2-way 15" passive floor monitor
Frequency Response (+/-3 dB)	55 Hz-20 kHz	45 Hz-20 kHz
Sensitivity (1 w @ 1 m)	98 dB	99.5 dB
Dispersion (H x V)	90° x 60° (Rotatable)	90° x 60° (Rotatable)
RMS	500 w	700 w
Programme	1000 w	1400 w
Peak	2000 w	2800 w
Max SPL @ 1 m	133 dB	134 dB
Impedance	8 Ω	8 Ω
LF transducer voice coil	3.5"	4.0"
HF compression driver voice coil	3.2" - Neo	3.2" - Neo
Crossover frequency	1.9 kHz	1.9 kHz
Rigging points	10 x M10	10 x M10
H x W x D	658 x 372 x 377.6 mm	723 x 432 x 395.6 mm
Net weight	26 kg	33 kg



Model Name	WLA-210X	WLA-210XSUB	WLA-28	WLA-15B	WLA-28SUB
System Type	Passive	Passive	Passive	Passive	Passive
Configuration	Two-way 2 x 10"	Dual 15" Subwoofer	Two-way 2 x 8"	Subwoofer	2 x 15" subwoofer
Frequency Response (+/-3 dB)	65 Hz - 20 kHz	39 Hz - 900 Hz	70 Hz - 20 kHz	40 Hz - 1.5 kHz	39 Hz-900 Hz
Frequency Range (-10 dB)	60 Hz - 20 kHz	35 Hz -1.5 KHz	65 Hz - 20 kHz	35 Hz - 1.3 kHz	39 Hz-1.5 kHz
Sensitivity (2.83 v / 1 m)	102 dB	108 dB	100 dB	99 dB	108 dB
Calculated Maximum SPL @1 m	LF:135 dB HF:138 dB	145 dB	LF:128 dB HF:132 dB	133 dB	145 dB
System Rated Impedance	16 Ω	4 Ω	16 Ω	8 Ω	4 Ω

**Low Frequency Transducer**

Size	2 x 260 mm / 2 x 10"	2 x 381 mm / 2 x 15"	2 x 203.2 mm / 2 x 8"	381 mm / 15"	2 x 381 mm / 15"
Voice Coil Size	65 mm / 2.5"	101.6 mm / 4"	50.8 mm / 2"	101.6 mm / 4"	100 mm / 4"
Rated Impedance	8 Ω x 2	8 Ω x 2	8 Ω	8 Ω	2 x 8 Ω
LF Power (re:AES2-2012)	2 x 400 W	2 x 600 W	2 x 200 W	700 W	2 x 600 W

**High Frequency Transducer**

HF Driver Type	Compression Driver - Neo	-	Compression Driver	-	-
Voice Coil Size	75 mm / 3.0"	-	81.3 mm / 3.2"	-	-
Exit Size	35.56 mm / 1.4"	-	35.56 mm / 1.4"	-	-
Diaphragm Material	Titanium	-	Titanium	-	-
Rated Impedance	8 Ω	-	8 Ω	-	-
HF Power (re:AES2-2012)	80 W	-	80 W	-	-
Nominal Coverage (H x V)	100° x 10°	-	100° x 10°	-	-

**Power**

System Continuous Power	LF:800 W HF:90 W	1200 W	LF:400 W HF:75 W	700 W	1200 W
System Programme Power	LF:1800 W HF:180 W	2400 W	LF:800 W HF:150 W	1400 W	2400 W
System Peak Power	LF:3600 W HF:360 W	4800 W	LF:1600 W HF:300 W	2800 W	4800 W
Crossover frequency	1.5 kHz	No	1.8 kHz	No	No
Input Connector	2 x speakON compatible	2 x speakON compatible	2 x speakON compatible	2 x speakON compatible	2 x speakON compatible

<b>Hardware</b>	Integral side plate adjustable rigging 0°-10°	Integral side plate non adjustable	Integral side plate adjustable rigging 0°-10°	Integral side plate non adjustable	Integral side plate non adjustable
-----------------	---	------------------------------------	---	------------------------------------	------------------------------------

<b>Enclosure</b>					
Enclosure Material	15 mm / 18 mm Plywood	18 mm Plywood	15 mm Plywood	15 mm Plywood	15 mm,18 mm Plywood
Finish	Rhino Black Paint	Rhino Black Paint	Rhino Black Paint	Rhino Black Paint	Rhino Black Paint
Grille Material & Finish	1.2 mm Black Steel	1.2 mm Black Steel	1.2 mm Black Steel	1.2 mm Black Steel	1.2 mm Black Steel

**Dimensions - (Unpacked)**

Height Front	314 mm / 12.4"	485 mm / 19.1"	250 mm / 9.84"	485 mm / 19.09"	485 mm / 19.1"
Height Rear	240.2 mm / 9.46"	485 mm / 19.1"	188 mm / 7.4"	485 mm / 19.09"	485 mm / 19.1"
Width	760 mm / 29.9"	760 mm / 29.9"	760 mm / 29.92"	760 mm / 29.92"	760 mm / 29.9"
Depth	504 mm / 19.84"	716 mm / 28.2"	424 mm /16.69"	440 mm / 17.32"	716 mm / 28.2"

**Dimensions - (Packed)**

Height	404 mm / 15.9"	575 mm / 22.6"	375 mm / 14.76"	545 mm / 21.46"	850 mm / 33.5"
Width Front	855 mm / 33.7"	850 mm / 33.5"	545 mm / 21.46"	580 mm / 22.83"	575 mm / 22.6"
Width Rear	855 mm / 33.7"	850 mm / 33.5"	545 mm / 21.46"	580 mm / 22.83"	575 mm / 22.6"
Depth	594 mm / 23.4"	806 mm / 31.7"	855 mm / 33.66"	860 mm / 33.86"	806 mm / 31.7"

<b>Weight</b>					
Net Weight (kg / lbs)	34.8 kg / 76.6 lbs	63.0 kg / 138.4 lbs	27 kg / 59.52 lbs	38.5 kg / 84.88 lbs	61.2 kg / 134.6 lbs
Gross Weight (kg / lbs)	38.5 kg / 84.7 lbs	68.0 kg / 149.6 lbs	33 kg / 72.75 lbs	46.5 kg / 102.51 lbs	66.0 kg / 145.2 lbs



Model Name	WLA-25	WLA-25SUB	WLA-218SUB	WLA-218B
System Type	Passive	Passive	Passive	Passive
Configuration	Two-way	2 x 10" subwoofer	2 x 18" Dual Chamber Sub	2 x 18" subwoofer
Frequency Response (+/-3 dB)	108 Hz-18 kHz	56 Hz-1.5 kHz	30 Hz - 1.5 kHz	30 Hz - 1 kHz
Frequency Range (-10 dB)	108 Hz-20 kHz	56 Hz-2.0 kHz	30 Hz - 1.5 kHz	25 Hz - 800 Hz
Sensitivity (2.83 v / 1 m)	HF:108 dB / LF:100 dB	107 dB	100 dB	109 dB
Calculated Maximum SPL @1 m	HF:135 dB / LF:127 dB	141 dB	138 dB	148 dB
System Rated Impedance	16 Ω	4 Ω	Parallel 4 Ω, Discrete 8 Ω x 2	4 Ω

**Low Frequency Transducer**

Size	2 x 130 mm / 5"	2 x 254 mm / 10"	2 x 470 mm / 18"	2 x 470 mm / 18"
Voice Coil Size	35.0 mm / 1.4"	65.5 mm / 2.5"	102 mm / 4"	102 mm / 4"
Rated Impedance	16 Ω	8 Ω	2 x 8 Ω	2 x 8 Ω
LF Power (re:AES2-2012)	2 x 60 W	2 x 350 W	2 x 800 W	2 x 1000 W

**High Frequency Transducer**

HF Driver Type	Compression Driver - Neo	-	-	-
Voice Coil Size	44 mm / 1.75"	-	-	-
Exit Size	1"	-	-	-
Diaphragm Material	Titanium	-	-	-
Rated Impedance	16 Ω	-	-	-
HF Power (re:AES2-2012)	40 W	-	-	-
Nominal Coverage (H x V)	100° x 10°	-	-	-

**Power**

System Continuous Power	120 W	700 W	1600 W Parallel / 800 W Discrete	2000 W
System Programme Power	240 W	1400 W	3200 W Parallel /1600 W Discrete	4000 W
System Peak Power	480 W	2800 W	6400 W Parallel /3200 W Discrete	8000 W
Crossover frequency	3.7 kHz			
Input Connector	2 x speakON compatible	2 x speakON compatible	2 x speakON compatible	2 x speakON compatible

<b>Hardware</b>	Integral side plate adjustable rigging 0°-10°	Integral, non adjustable		
-----------------	---	--------------------------	--	--

<b>Enclosure</b>				
Enclosure Material	15 mm,18 mm Plywood	15 mm,18 mm Plywood	18 mm Plywood	18 mm Plywood
Finish	Rhino Black or white paint	Rhino Black or white paint	Rhino Rock black paint	Rhino Rock black paint
Grille Material & Finish	Steel	Steel	Steel	Steel

**Dimensions - (Unpacked)**

Height Front	164.5 mm / 6.47"	400 mm / 15.74"	541 mm / 21.3"	560 mm / 22.0"
Height Rear	112.5 mm / 4.4"	400 mm / 15.74"	541 mm / 21.3"	560 mm / 22.0"
Width	536 mm / 21.1"	536 mm / 21.10"	1041 mm / 41"	1065 mm / 41.9"
Depth	363 mm / 14.3"	550 mm / 21.65"	650 mm / 25.6"	756 mm / 29.8"

**Dimensions - (Packed)**

Height	606 mm / 23.85"	610 mm / 24.01"	626 mm / 25.6"	638 mm / 25.1"
Width Front	430 mm / 16.92"	470 mm / 18.50"	1126 mm / 44.3"	1138 mm / 44.8"
Width Rear	430 mm / 16.92"	470 mm / 18.50"	1126 mm / 44.3"	1138 mm / 44.8"
Depth	235 mm / 9.25"	596 mm / 23.46"	722 mm / 28.4"	829 mm / 32.6"

<b>Weight</b>				
Net Weight (kg / lbs)	13.0 kg / 28.66 lbs	37.0 kg / 81.57 lbs	78.9 kg / 173.5 lbs	74.3 kg / 164 lbs
Gross Weight (kg / lbs)	15.0 kg / 33.06 lbs	39.5 kg / 87.08 lbs	86.0 kg / 189.6 lbs	88.2 kg / 194 lbs



# INSTALLATION

TOOLS TO MAKE IT EASY TO CREATE THE PERFECT INSTALL



Designing and installing a PA system can be complex. It is important to know the exact product dimensions, precise specifications and what other hardware is needed to make the installation process as simple as possible.

To make this easy, there are downloadable 'Data Sheets' for all of the Wharfedale Pro Installation series and line array models.

These 'Data Sheets' give you the facts and figures needed to create powerful, reliable and extensive system installations.

- Precise cabinet measurements
- Comprehensive product specifications
- Clear rigging point measurements
- **Free downloads from [www.wharfedalepro.com](http://www.wharfedalepro.com)**

EASE Data is also available for many Wharfedale Pro line array models.

These data files make configuration and planning predictable.



And, for even more control over the installation and system setup, Wharfedale Pro Versadrive DSP systems have preset files available to make building a system easy and straightforward.

Delta series, Focus series and WLA systems can be designed using the supplied software and free downloadable presets.



# WH NEO

Its a TRIO.....of NEO.



WH-10 NEO



WH-12 NEO



WH-15 NEO

Using neodymium magnets in both the LF and HF drivers and plywood construction, the WH-NEO's deliver high power handling from a lightweight and good looking installation-ready cabinet.

Model Name	WH-10 NEO	WH-12 NEO	WH-15 NEO
System Type	Passive - 2 way	Passive - 2 way	Passive - 2 way
Frequency Response (+/-3 dB)	65-18 kHz	55-18 kHz	50-18 kHz
Frequency Range (-10 dB)	60-20 kHz	50-20 kHz	45-20 kHz
Sensitivity 2.83 v / 1 m	97 dB	98 dB	99 dB
Calculated Maximum SPL @1 m	128 dB	130 dB	132 dB
System Rated Impedance	8 Ω	8 Ω	8 Ω
LF : Size (mm / inches)	288 mm / 10"	305 mm / 12"	381 mm / 15"
LF :Voice Coil Size (mm / inches)	63.5 mm / 2.5"	75 mm / 3.0"	75 mm / 3.0"
LF Magnet Material	NdFeB	NdFeB	NdFeB
LF Power re:AES2-2012	300 W	400 W	500 W
HF Driver Type:	1" Compression Driver	1" Compression Driver	1" Compression Driver
HF Coil Size (mm / inches)	44 mm / 1.75"	44 mm / 1.75"	44 mm / 1.75"
HF Magnet Material	NdFeB	NdFeB	NdFeB
HF Diaphragm Material	Titanium	Titanium	Titanium
Waveguide Type	Rounded	Rounded	Rounded
Nominal Coverage (H x V)	70° x 70°	70° x 70°	70° x 70°
System Continuous Power	300 w	400 w	500 w
System Programme Power	600 w	800 w	1000 w
System Peak Power	1200 w	1600 w	2000 w
Crossover frequency	2.5 kHz	2.5 kHz	2.5 kHz
<b>CONNECTORS:</b> Input Connector	2 * NL4 (speakON compatible)	2 * NL4 (speakON compatible)	2 * NL4 (speakON compatible)
Rigging	M8 * 19	M8 * 19	M8 * 19
Pole mount	35 mm pole socket	35 mm pole socket	35 mm pole socket
Handles	NO	NO	NO
<b>ENCLOSURE:</b> Cabinet type	Trapezoid	Trapezoid	Trapezoid
Enclosure Material and finish	15 mm plywood / Black paint	15 mm plywood / Black paint	15 mm plywood / Black paint
Grille Material & Finish	Steel	Steel	Steel
<b>Dimensions - Unpacked:</b> Height	533 mm / 21.0"	600 mm / 23.6"	680 mm / 26.8"
Width Front	310 mm / 12.2"	350 mm / 13.8"	430 mm / 16.9"
Width Rear	210 mm / 8.3"	242 mm / 9.5"	298 mm / 11.7"
Depth	342 mm / 13.5"	388 mm / 15.3"	463 mm / 18.2"
<b>Dimensions - Packed:</b> Height	615 mm / 24.2"	680 mm / 26.8"	760 mm / 29.9"
Width Front / Rear	386 mm / 15.2"	426 mm / 16.8"	506 mm / 19.9"
Depth	416 mm / 16.4"	458 mm / 18.0"	526 mm / 20.7"
Net Weight (kg / lbs)	15.0 kg / 33 lbs	18.8 kg / 41.4 lbs	23.7 kg / 52.1 lbs
Gross Weight (kg / lbs)	18.7 kg / 41.1 lbs	22.6 kg / 49.7 lbs	27.6 kg / 60.7 lbs

# i Series

**IP54 Certified, ABS plastic installation speakers - with transformer option**



- Durable ABS construction with full face grilles
- 8", 6.5" or 4" low impedance 8 Ω models
- 8", 6.5" or 4" 70 v / 100 v Transformer models
- Available in BLACK or WHITE
- Integral mounting bracket - included
- Seismic restraint tethers - included
- Easy installation
- Supplied in pairs

Designed specifically for small to medium scale commercial installations, the 'i series' is made up of 3 ABS plastic models (4", 6.5" and 8"). Each model is available in a 70 v / 100 v or in a 8 Ω low impedance configuration and is available in Black or White.

## MOUNTING

All models are supplied with fully adjustable steel wall mounting brackets. (No more searching through websites looking for compatible mounting hardware! The brackets come inside the box.)

These brackets are simple to install and give comprehensive adjustment angles due to the semi-circular 'ball and socket' design.

i series are easy to mount, easy to adjust and simple to securely lock in place.

There is also a threaded insert for attachment of the included seismic restraint tether.

## DRIVERS

Internally, the i series use a two-way design with a 1.0" silk dome tweeter and custom Wharfedale Pro 4", 6.5" or 8" low frequency drivers.

This combination results in a natural sounding speaker that suits both prerecorded music playback or voice applications.



## Installation Speakers

### i4T

The 70/100 V i4T model uses one terminal for the Common (-) connection and the other three terminals for the transformer power taps. The i4T offers taps at 25 W, 12.5 W and 6.25 W

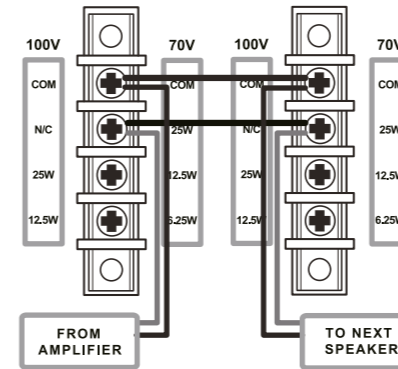

### i8T / i6T

The i8T and i6T are fitted with two terminals for the (+) and (-) incoming amplifier feed and two terminals for connection to the next speaker if used.

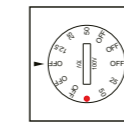
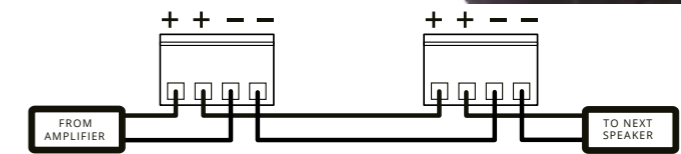

An adjustable voltage selector allows for accurate and secure power settings. Set and forget.

Model Name	i4	i4T	i6	i6T	i8	i8T
System Type	Passive	Passive	Passive	Passive	Passive	Passive
Configuration	Two-way	Two-way	Two-way	Two-way	Two-way	Two-way
Frequency Response (+/-3 dB)	100 Hz - 20 kHz	100 Hz - 20 kHz	70 Hz - 20 kHz	70 Hz - 20 kHz	70 Hz - 20 kHz	70 Hz - 20 kHz
Frequency Range (-10 dB)	60 Hz - 20 kHz	60 Hz - 20 kHz	50 Hz - 20 kHz	50 Hz - 20 kHz	50 Hz - 20 kHz	50 Hz - 20 kHz
Sensitivity (2.83 v/1 m)	84 dB	83 dB	86 dB	85 dB	87 dB	86 dB
Calculated Maximum SPL @1 m	105 dB	95 dB	109 dB	102 dB	110 dB	103 dB
System Rated Impedance	8 Ω	n/a	8 Ω	n/a	8 Ω	n/a
<b>Low Frequency Transducer</b>						
Size	4"	4"	6.5"	6.5"	8"	8"
Voice Coil Size	1"	1"	1"	1"	1"	1"
Rated Impedance	8 Ω	8 Ω	8 Ω	8 Ω	8 Ω	8 Ω
LF Power (re:AES2-2012)	25 W	25 W	50 W	50 W	50 W	50 W
<b>High Frequency Transducer</b>						
HF Driver Type	Soft dome tweeter	Soft dome tweeter	Soft dome tweeter	Soft dome tweeter	Soft dome tweeter	Soft dome tweeter
Voice Coil Size	1"	1"	1"	1"	1"	1"
Diaphragm Material	Silk	Silk	Silk	Silk	Silk	Silk
Rated Impedance	8 Ω	8 Ω	8 Ω	8 Ω	8 Ω	8 Ω
HF Power (re:AES2-2012)	10 W	10 W	10 W	10 W	10 W	10 W
Nominal Coverage (H x V)	130° x 180°	130° x 180°	150° x 170°	150° x 170°	130° x 180°	130° x 180°
<b>Power</b>						
System Continuous Power	25 W	70 V : 6.25 W / 12.5 W / 25 W	50 W	70 V : 12.5 W / 25 W / 50 W	50 W	70 V : 12.5 W / 25 W / 50 W
System Programme Power	50 W	100 V : 12.5 W / 25 W	100 W	100 V : 25 W / 50 W	100 W	100 V : 25 W / 50 W
System Peak Power	100 W		200 W		200 W	
Crossover frequency	2.8 kHz	2.8 kHz	2.2 kHz	2.2 kHz	2.0 kHz	2.0 kHz
Input Connector	Screw terminal	Screw terminal	Phoenix terminal	Phoenix terminal	Phoenix terminal	Phoenix terminal
Hardware	Wall bracket included	Wall bracket included	Wall bracket included	Wall bracket included	Wall bracket included	Wall bracket included
<b>Enclosure</b>						
Enclosure Material and finish	Plastic (ABS)	Plastic (ABS)	Plastic (ABS)	Plastic (ABS)	Plastic (ABS)	Plastic (ABS)
Colour Options	Black or White	Black or White	Black or White	Black or White	Black or White	Black or White
Grille Material & Finish	Aluminium	Aluminium	Aluminium	Aluminium	Aluminium	Aluminium
<b>Dimensions - Unpacked</b>						
Height	232 mm / 9.1"	232 mm / 9.1"	370 mm / 14.6"	370 mm / 14.6"	405 mm / 15.8"	405 mm / 15.8"
Width	160 mm / 6.3"	160 mm / 6.3"	245 mm / 9.6"	245 mm / 9.6"	270 mm / 10.6"	270 mm / 10.6"
Depth	148 mm / 5.8"	148 mm / 5.8"	216 mm / 8.5"	216 mm / 8.5"	234 mm / 9.2"	234 mm / 9.2"
<b>Dimensions - Packed(1 PAIR)</b>						
Height	335 mm / 13.2"	335 mm / 13.2"	495 mm / 19.5"	495 mm / 19.5"	549 mm / 21.6"	549 mm / 21.6"
Width	425 mm / 16.7"	425 mm / 16.7"	565 mm / 22.3"	565 mm / 22.3"	602 mm / 23.7"	602 mm / 23.7"
Depth	210 mm / 8.3"	210 mm / 8.3"	340 mm / 13.4"	340 mm / 13.4"	363 mm / 14.3"	363 mm / 14.3"
<b>Weight</b>						
Net Weight (single speaker)	2.1 kg / 4.62 lbs	2.72 kg / 5.98 lbs	4.3 kg / 9.46 lbs	5.3 kg / 11.6 lbs	4.7 kg / 10.34 lbs	5.7 kg / 12.54 lbs
Gross Weight(1PAIR,Inc Bracket)	5.86 kg / 12.9 lbs	7.1 kg / 15.6 lbs	11.12 kg / 24.5 lbs	13.75 kg / 30.25 lbs	12.7 kg / 27.9 lbs	14.7 kg / 32.34 lbs



# SIGMA Series

SPECIFICALLY ENGINEERED FOR FIXED INDOOR INSTALLATIONS



Titanium  
Compression Driver



Advanced Crossover  
Design



Clear sound with excellent  
off-axis rejection



Ready for Rigging



Durable, Painted  
Speaker Cabinet



Black and white versions



Available in black or white and with comprehensive rigging options SIGMA SERIES is already a versatile and favourite choice for installers.

## DOUBLE ROLL SURROUND & DRIVER TECHNOLOGY

Sigma Series loudspeakers use the latest in Wharfedale Pro driver technology: For the LF drivers, engineers have incorporated a curvilinear, double-roll surround for smooth mid-high transitions and stability for low through to mid range frequencies. Combined with 2.5" voice coils (on 12, 15 and 18B models) for improved thermal dissipation, users can expect consistent delivery at the highest of volumes throughout a performance. The 44 mm diaphragm HF driver used in the 10", 12" and 15" models is equally robust in design – using a solid aluminum rear plate, the HF driver is strengthened for durability and heat is dissipated efficiently for demanding environments. Wharfedale Pro engineers have selected a 90° x 60° waveguide optimised for wide coverage for fixed installation purposes.

## ACOUSTICALLY MATCHED CABINET

Wharfedale Pro engineers have matched the acoustic properties of the cabinet to the proprietary driver technology within, while taking physical aspects into consideration to ensure optimal positioning and size for installation. By using a newly-developed angled-corner port system, cabinet height and overall size has been reduced – ideal for unobtrusive mounting within your venue. Additionally the angle-corner port system is fine-tuned acoustically to ensure low-end punch – just as you would expect with a larger PA speaker. The cabinets of the SIGMA 10, 12 and 15 also feature dual-angle pole mount sockets ensuring the long-throw HF driver projects the sound directly to your audience. There are also 5 x M8 rigging points for safe and secure flying where needed. SIGMA Series is coated in the latest generation chip-resistant, Rhino Rock paint.

## Installation Speakers

### FINE-TUNED CROSSOVER

The crossovers ensure perfect integration between the drive units and acoustic properties of the cabinet. Electronic components are carefully selected, while over-complex networks have been avoided to maintain a pure and strong audio signal. Engineers have fine-tuned the crossover points for vocal intelligibility and tuned the high frequencies for long-throw to ensure clear coverage right to the back of your venue.

### SIGMA V4 and V8

#### High powered column formation models

Using true line array technology, the V4 and V8 are perfect for sound reinforcement installations where discreet aesthetics, high coverage angles and SPL are critical.

Both 'V' models use multiple 3" full range transducers for warm lows and crystal clear highs. Optimised transducer alignment delivers minimal anti-aliasing effects and maximum phase alignment.

With programme power ratings of 300 watts (V4) and 600 watts (V8) and their Ultra-wide horizontal dispersion, these column models have been voiced to work perfectly with other models in the Wharfedale Pro SIGMA range.

Both are supplied with swivel/tilt mounting brackets and are available in black or white finishes.



### SIGMA 18B Subwoofer

With power ratings of 500 watts AES (RMS), 1000 watts Program and 2000 watts Peak, the SIGMA 18B delivers impressive low-end punch. SIGMA 18B also features an NL4 (speakON compatible) High Pass Output connector allowing for direct connection to another model in the SIGMA series.

- Discreet and unobtrusive design
- Newly developed angled corner port system to reduce dimensions
- Multiple M8 rigging points and a two way speaker pole mount for easy installation
- Crossovers tailored for vocal intelligibility
- Chip resistant Rhino Rock paint
- Double roll surround LF driver for stability and power
- High performance HF driver with aluminium rear cover for maximum heat dissipation
- 2.5" voice coils on 12", 15" and 18B models
- Series includes 2 column line array models with 160° horizontal dispersion
- 7 models available in black or white in the range for maximum flexibility



Model Name	SIGMA-8	SIGMA-10	SIGMA-12	SIGMA-15
System Type	Passive	Passive	Passive	Passive
Configuration	Two-way	Two-way	Two-way	Two-way
Frequency Response (+/-3 dB)	70 - 18 kHz	65 - 18 kHz	60 - 18 kHz	50 - 18 kHz
Frequency Range (-10 dB)	65 - 20 kHz	60 - 20 kHz	55 - 20 kHz	45 - 20 kHz
Sensitivity 2.83 v / 1 m	94 dB	95 dB	97 dB	98 dB
Calculated Maximum SPL @1 m	122 dB	124 dB	128 dB	129 dB
System Rated Impedance	8 Ω	8 Ω	8 Ω	8 Ω
<b>Low Frequency Transducer</b>				
Size (mm / inches)	203 mm / 8"	254 mm / 10"	305 mm / 12"	381 mm / 15"
Voice Coil Size (mm / inches)	38 mm / 1.5"	38 mm / 1.5"	64 mm / 2.5"	64 mm / 2.5"
Rated Impedance	8 Ω	8 Ω	8 Ω	8 Ω
LF Power re:AES2-2012	150 w	200 w	300 w	350 w
<b>High Frequency Transducer</b>				
HF Driver Type	Compression Driver	Compression Driver	Compression Driver	Compression Driver
Coil Size (mm / inches)	25 mm / 1"	44 mm / 1.75"	44 mm / 1.75"	44 mm / 1.75"
Exit Size (mm / inches)	1"	1"	1"	1"
Diaphragm Material	Polymer	Titanium	Titanium	Titanium
Rated Impedance	8 Ω	8 Ω	8 Ω	8 Ω
HF Power re:AES2-2012	25 w	40 w	40 w	40 w
Nominal Coverage (H x V)	90° x 60°	90° x 60°	90° x 60°	90° x 60°
<b>Power</b>				
System Continuous Power	150 w	200 w	300 w	350 w
System Programme Power	300 w	400 w	600 w	700 w
System Peak Power	600 w	800 w	1200 w	1400 w
Crossover frequency	2.8 kHz	2.4 kHz	2.2 kHz	2.2 kHz
Input Connector	2 x NL4 (speakON compatible)	2 x NL4 (speakON compatible)	2 x NL4 (speakON compatible)	2 x NL4 (speakON compatible)
Hi Pass output connector				
Pole mount	35 mm pole socket	Dual-angle (0° / 10°) 35 mm socket	Dual-angle (0° / 10°) 35 mm socket	Dual-angle (0° / 10°) 35 mm socket
Hardware	M8 x 5	M8 x 5	M8 x 5	M8 x 5
	1 handle on back	1 handle on back	2 handles on sides	2 handles on sides
<b>Enclosure:</b>				
Enclosure Material	12 mm MDF	15 mm MDF	15 mm MDF	15 mm MDF
Finish	Black or white	Black or white	Black or white	Black or white
Grille Material & Finish	1.2 mm steel, painted	1.2 mm steel, painted	1.2 mm steel, painted	1.2 mm steel, painted
<b>Dimensions - Unpacked</b>				
Height	430 mm / 17"	500 mm / 19.5"	537 mm / 21"	635 mm / 25"
Width Front	272 mm / 11"	383 mm / 13.3"	354 mm / 14"	435 mm / 17"
Width Rear	158 mm / 6"	213 mm / 8.4"	218 mm / 8"	261 mm / 11.7"
Depth	277 mm / 13.5"	339 mm / 13.35"	359 mm / 14"	439 mm / 17.25"
<b>Dimensions - Packed</b>				
Height	505 mm / 20"	585 mm / 23"	625 mm / 24.6"	720 mm / 28.35"
Width Front	363 mm / 14.25"	451 mm / 18"	468 mm / 18.4"	553 mm / 21.75"
Width Rear	196 mm / 7.71"	254 mm / 10"	260 mm / 10.2"	303 mm / 12"
Depth	322 mm / 12.75"	384 mm / 13.3"	404 mm / 15.9"	488 mm / 19.2"
<b>Weight</b>				
Net Weight	7.8 kg / 17 lbs	15.4 kg / 34 lbs	18.2 kg / 40 lbs	23.4 kg / 51.5 lbs
Gross Weight	8.8 kg / 19 lbs	17.8 kg / 38.5 lbs	20.9 kg / 45 lbs	26.7 kg / 58.7 lbs



Model Name	SIGMA-18B	SIGMA-V4	SIGMA-V8
System Type	Passive	Passive	Passive
Configuration	Subwoofer	Full Range Column	Full Range Column
Frequency Response (+/-3 dB)	35 - 250 Hz	160 - 17 kHz	130 - 17 kHz
Frequency Range (-10 dB)	30 - 250 Hz	150 - 20 kHz	120 - 20 kHz
Sensitivity 2.83 v / 1 m	100 dB	95 dB	97 dB
Calculated Maximum SPL @1 m	133 dB	123 dB	128 dB
System Rated Impedance	4 Ω	8 Ω	8 Ω
<b>Low Frequency Transducer</b>			
Size (mm / inches)	457 mm / 18"	4 x 75 mm / 3"	8 x 75 mm / 3"
Voice Coil Size (mm / inches)	64 mm / 2.5"	33 mm / 1.3"	33 mm / 1.3"
Rated Impedance	4 Ω	8 Ω	4 Ω
LF Power re:AES2-2012	500 w	40 w	40 w
<b>High Frequency Transducer</b>			
HF Driver Type	na	na	na
Coil Size (mm / inches)	na	na	na
Exit Size (mm / inches)	na	na	na
Diaphragm Material	na	na	na
Rated Impedance	na	na	na
HF Power re:AES2-2012	na	na	na
Nominal Coverage (H x V)	na	80° Horizontal	80° Horizontal
<b>Power</b>			
System Continuous Power	500 w	150 w	300 w
System Programme Power	1000 w	300 w	600 w
System Peak Power	2000 w	600 w	1200 w
Crossover frequency	150 Hz	na	na
Input Connector	2 x NL4 (speakON compatible)	1 x NL4 (speakON compatible)	1 x NL4 (speakON compatible)
Hi Pass output connector	1 x NL4 (speakON compatible)		
Pole mount	35 mm pole socket	Bracket (included)	Bracket (included)
Hardware	4 handles on sides		
<b>Enclosure</b>			
Enclosure Material	18 mm MDF	12 mm MDF	12 mm MDF
Finish	Black or white	Black or white	Black or white
Grille Material & Finish	1.2 mm steel, painted	1.2 mm steel, painted	1.2 mm steel, painted
<b>Dimensions - Unpacked</b>			
Height	554 mm / 21.25"	445 mm / 17.5"	805 mm / 32"
Width Front	502 mm / 20"	116 mm / 4.6"	116 mm / 4.6"
Width Rear	502 mm / 20"	85 mm / 3.3"	85 mm / 3.3"
Depth	780 mm / 30.8"	115 mm / 4.5"	115 mm / 4.5"
<b>Dimensions - Packed</b>			
Height	649 mm / 25.5"	520 mm / 20.5"	880 mm / 34.5"
Width Front	588 mm / 22.75"	220 mm / 8.7"	220 mm / 8.7"
Width Rear	588 mm / 22.75"	220 mm / 8.7"	220 mm / 8.7"
Depth	865 mm / 34"	220 mm / 8.7"	220 mm / 8.7"
<b>Weight</b>			
Net Weight	39.1 kg / 86 lbs	3 kg / 6.6 lbs	5.6 kg / 12.32 lbs
Gross Weight	46.4 kg / 102 lbs	3.6 kg / 8 lbs	6.6 kg / 14.2 lbs



# PROGRAMME Series

## DISCREET AND STYLISH FIXED INSTALLATION PA

70V  
100V



Available in 70V/100V  
Line Configurations

Lightweight

Discreet Visual  
Design

Full Range Sound

Multiple Installation  
Options

Durable, Painted  
Speaker Cabinet

### Stylish, Compact & Discrete

The discreet and stylish appearance of the Programme Series seamlessly integrates into any architectural environment. Frequency response has been optimised to be smooth and natural across the vocal range for high intelligibility in difficult environments, while retaining the neutral and uncoloured sound essential for unobtrusive reproduction of background music.

### Low impedance compatibility

Programme series feature a separate low impedance input for loss free connection to a low impedance amplifier. Many models also feature a mode switch which bypasses the secondary coil of the line transformer, eliminating insertion loss. This combination of separate input and mode switch also protects the unit from incorrect connection to a 70/100 v line system in low impedance mode.

### Flexible, easy installation

Lightweight compact enclosures make the Programme Series easy to install. From the compact 35E to the multiple drivers of the 406, you have the flexibility needed to provide the best sound value. With the included mounting brackets and the transformer option, you will be impressed with the ease of wall or ceiling mounting as well as the clear, accurate sound produced by these speakers.

- 2-way installation speaker systems
- Mylar, silk and titanium HF drivers used across range
- Low distortion, high power woofers
- M6 or M8 high hanging points
- NL4 (speakON compatible), parallel spring crimp and barrier strip inputs
- Supplied with adjustable heavy duty steel bracket
- Models available with 70 volts / 100 volts Transformer ('T' model)
- Most models available in black or white finishes



## Installation Speakers

Model Name	Programme 35E / 35ET	Programme 105 / 105T	Programme 108 / 108T	Programme 205 / 205T	Programme 206 / 206T	Programme 406 / 406T
System Type	Passive	Passive	Passive	Passive	Passive	Passive
Configuration	Two-way	Two-way	Two-way	Two-way	Two-way	Two-way
Freq Response (+/-3 dB)	65 Hz - 20 kHz	75 Hz - 20 kHz	60 Hz - 20 kHz	70 Hz - 20 kHz	65 Hz - 20 kHz	60 Hz - 20 kHz
Frequency Range (-10 dB)	60 Hz - 20 kHz	70 Hz - 20 kHz	55 Hz - 20 kHz	65 Hz - 20 kHz	60 Hz - 20 kHz	55 Hz - 20 kHz
Sensitivity (2.83 v / 1 m)	88 dB	89 dB	90 dB	91 dB	93 dB	96 dB
Calculated Max SPL @1 m	112 dB	114 dB	118 dB	117 dB	120 dB	126 dB
System Rated Impedance	8 Ω	8 Ω	8 Ω	8 Ω	8 Ω	8 Ω
<b>LF Transducer</b>						
Size	165.1 mm / 6.5"	127 mm / 5"	203.2 mm / 8"	2 x 127 mm / 2 x 5"	2 x 165.1 mm / 2 x 6.5"	4 x 165.1 mm / 2 x 6.5"
Voice Coil Size	25.5 mm / 1"	25.5 mm / 1"	51.5 mm / 2"	25.5 mm / 1"	25.5 mm / 1"	25.5 mm / 1"
Rated Impedance	8 Ω	8 Ω	8 Ω	8 Ω	8 Ω	8 Ω
LF Power (re:AES2-2012)	60 w	60 w	150 w	2 x 50 w	2 x 65 w	4 x 65 w
<b>HF Transducer</b>						
<b>HF Driver Type</b>						
Voice Coil Size	25.4 mm / 1"	25.4 mm / 1"	25.4 mm / 1"	25.4 mm / 1"	25.4 mm / 1"	25.4 mm / 1"
Exit Size	25.4 mm / 1"	25.4 mm / 1"	25.4 mm / 1"	25.4 mm / 1"	25.4 mm / 1"	25.4 mm / 1"
Diaphragm Material	silk Dome	titanium	titanium	titanium	titanium	titanium
Rated Impedance	8 Ω	8 Ω	8 Ω	8 Ω	8 Ω	8 Ω
HF Power (re:AES2-2012)	10 w	15 w	15 w	15 w	15 w	15 w
Nominal Coverage (H x V)	70° x 70°	60° x 60°	60° x 60°	60° x 60°	60° x 60°	60° x 60°
<b>Power</b>						
System Continuous Power	60 w	80 w	150 w	100 w	150 w	250 w
System Programme Power	120 w	160 w	300 w	200 w	300 w	500 w
System Peak Power	240 w	320 w	600 w	400 w	600 w	1000 w
Crossover frequency	2.3 kHz	2.3 kHz	2.3 kHz	2.3 kHz	2.3 kHz	2.3 kHz
Input Connector	Bare Wire Spring	Barrier Strip	2 x NL4 + Barrier Strip	Barrier Strip	2 x NL4 + Barrier Strip	2 x NL4 + Barrier Strip
<b>Hardware</b>						
Rigging	M6 x 4 (Bracket Inc.)	M8 x 14	M8 x 18	M8 x 18	M8 x 18	M8 x 18
Mounting bracket	Included	Included	Included	Included	Included	Included
<b>Enclosure</b>						
Enclosure Material	MDF	MDF	MDF	MDF	MDF	MDF
Finish	Black Paint	Black / White Paint	Black / White Paint	Black / White Paint	Black / White Paint	Black / White Paint
Grille Material & Finish	Black Full (Cloth)	Black / White Full (Steel)	Black / White Full (Steel)	Black / White Full (Steel)	Black / White Full (Steel)	Black / White Full (Steel)
<b>Dimensions - Unpacked</b>						
Height	275 mm / 10.83"	304 mm / 11.97"	458 mm / 18.03"	500 mm / 19.69"	660.5 mm / 26"	980 mm / 38.58"
Width Front	196 mm / 7.72"	184 mm / 7.24"	248 mm / 9.76"	184 mm / 7.24"	215 mm / 8.46"	215 mm / 8.46"
Width Rear	196 mm / 7.72"	184 mm / 7.24"	248 mm / 9.76"	184 mm / 7.24"	215 mm / 8.46"	215 mm / 8.46"
Depth	192 mm / 7.56"	205 mm / 8.07"	275 mm / 10.83"	205 mm / 8.07"	275 mm / 10.82"	275 mm / 10.82"
<b>Dimensions - Packed</b>						
Height	326 mm / 12.8"(pair)	379 mm / 14.9"	543 mm / 21.4"	585 mm / 23.0"	745 mm / 29.3"	1065 mm / 41.9"
Width Front	488 mm / 19.2"(pair)	250 mm / 9.8"	311 mm / 12.2"	250 mm / 9.8"	278 mm / 10.9"	278 mm / 10.9"
Width Rear	488 mm / 19.2"(pair)	250 mm / 9.8"	311 mm / 12.2"	250 mm / 9.8"	278 mm / 10.9"	278 mm / 10.9"
Depth	256 mm / 10.1(pair)	274 mm / 10.8"	346 mm / 13.6"	274 mm / 10.8"	346 mm / 13.6"	346 mm / 13.6"
<b>Weight</b>						
Net Weight / T-model	6.2 kg / 8.06 kg(pair)	5.22 kg / 6.3 kg	9.34 kg / 10.8 kg	11.36 kg / 13.86 kg	17.8 kg / 20.3 kg	9.34 kg / 10.8 kg
Gross Weight / T-model	8.3 kg / 10.16 kg(pair)	6.59 kg / 7.7 kg	12.66 kg / 15.16 kg	14.05 kg / 16.5 kg	20.95 kg / 23.45 kg	12.66 kg / 15.16 kg

# SI-X Series

UNOBTRUSIVE, FIXED SOUND INSTALLATION WITH SONIC ACCURACY



Advanced Crossover Design



Circular Horn Design



Advanced motor systems



Clear sound with excellent off-axis rejection



Multiple Installation Options



Durable, Painted Speaker Cabinet



The SI-X speaker series have been designed for unobtrusive fixed installation, where sonic accuracy, detail and high SPL are essential characteristics.

From the SI-10X to the SI-15X plus three high power subs, you have what it takes to assemble the system that your music deserves. With both barrier strip and 2 x NL4 (speakON compatible) connectors, SI-X also offers versatility when making the connections.

An important factor in loudspeakers is the smoothness of the sound coverage. Many speakers that may sound acceptable in the horizontal plane have problems in the vertical plane. The SI-X speakers exhibit very smooth and well-behaved sound dispersion characteristics in both the horizontal and vertical planes making positioning and set-up less critical. Everyone in the room will hear the same quality sound.

Because of the multi-faceted cabinet design, the SI-X speakers can be positioned on the floor as a stage monitor or mounted on a wall or ceiling (using the U-shaped brackets included with the speaker).

The SI-X Series rugged cabinets feature 20 x M8 threaded inserts to facilitate the safe installation of the loudspeaker and are available in black or white durable paint finishes.

- 2-way reflex systems
- Folded horn and Direct Radiating subwoofers
- 25.4 mm Titanium high frequency compression drivers
- Low distortion, high power woofers
- 70° x 70° High Frequency Horn
- Multifaceted 40° x 50° durable MDF enclosure
- 20 x M8 hanging points for easy and safe rigging
- NL4 (speakON compatible) & Barrier Strip inputs
- Available in black or white durable paint finishes
- U-shaped steel mounting bracket included

## Installation Speakers



Model Name	SI-10X	SI-12X	SI-15X	SI-28X	SI-12BX	SI-15BX	SI-18BX
System Type	Passive	Passive	Passive	Passive	Passive	Passive	Passive
Configuration	Two-way	Two-way	Two-way	Two-way	Subwoofer	Subwoofer	Subwoofer
Freq Response (+/-3 dB)	60 Hz - 20 kHz	60 Hz - 20 kHz	50 Hz - 20 kHz	60 Hz - 20 kHz	40 Hz - 250 Hz	38 Hz - 220 Hz	35 Hz - 200 kHz
Freq Range (-10 dB)	55 Hz - 20 kHz	55 Hz - 20 kHz	45 Hz - 20 kHz	55 Hz - 20 kHz	35 Hz - 250 Hz	35 Hz - 220 Hz	30 Hz - 200 kHz
Sensitivity (2.83 v / 1 m)	93 dB	96 dB	97 dB	91 dB	101 dB	105 dB	99 dB
Calculated Max SPL @1 m	121 dB	126 dB	129 dB	121 dB	132 dB	138 dB	134 dB
System Impedance	8 Ω	8 Ω	8 Ω	8 Ω or 4 Ω	8 Ω or 4 Ω	8 Ω or 4 Ω	8 Ω or 4 Ω
<b>LF Transducer</b>							
Size	254 mm / 10"	304.9 mm / 12"	381 mm / 15"	2 x 203.2 mm / 8"	304.8 mm / 12"	381 mm / 15"	470 mm / 18"
Voice coil Size	38.9 mm / 1.5"	64.3 mm / 2.5"	77.1 mm / 3.0"	51.6 mm / 2.0"	102 mm / 4"	102 mm / 4"	102 mm / 4"
Rated Impedance	8 Ω	8 Ω	8 Ω	8 Ω or 4 Ω	8 Ω or 4 Ω	8 Ω or 4 Ω	8 Ω or 4 Ω
LF Power (re:AES2-2012)							
<b>HF Transducer</b>							
HF Driver Type	Compression Driver	Compression Driver	Compression Driver	Compression Driver	-	-	-
Voice coil Size	44 mm / 1.75"	44 mm / 1.75"	44 mm / 1.75"	44 mm / 1.75"	-	-	-
Exit Size	25 mm / 1"	25 mm / 1"	25 mm / 1"	25 mm / 1"	-	-	-
Diaphragm Material	Titanium	Titanium	Titanium	Titanium	-	-	-
Rated Impedance	8 Ω	8 Ω	8 Ω	8 Ω	-	-	-
HF (re:AES2-2012)	40 W	40 W	40 W	40 W	-	-	-
Nominal Coverage	70° x 70°	70° x 70°	70° x 70°	70° x 70°	-	-	-
<b>Power</b>							
Continuous Power	200 W	250 W	400 W	250 W	300 W	450 W	800 W
Programme Power	400 W	500 W	800 W	500 W	600 W	900 W	1600 W
Peak Power	800 W	1000 W	1600 W	1000 W	1200 W	1800 W	3200 W
Crossover frequency	2.5 kHz	2.4 kHz	2.5 kHz	2.6 kHz	-	-	-
Input Connector	2 x NL4 + Barrier Strip	2 x NL4 + Barrier Strip	2 x NL4 + Barrier Strip	2 x NL4 + Barrier Strip	2 x NL4 + Barrier Strip	2 x NL4 + Barrier Strip	2 x NL4 + Barrier Strip
<b>Hardware</b>							
Rigging	20 x M8 Points + Wall Bracket	20 x M8 Points + Wall Bracket	20 x M8 Points + Wall Bracket	20 x M8 Points + Wall Bracket			
Pole Mount	No	No	No	No	No	No	No
<b>Enclosure</b>							
Enclosure Material	MDF	MDF	MDF	MDF	MDF	MDF	MDF
Finish	Black or White	Black or White	Black or White	Black or White	Black or White	Black or White	Black or White
Grille Material & Finish	1.2 mm Steel	1.2 mm Steel	1.2 mm Steel	1.2 mm Steel	1.2 mm Steel	1.2 mm Steel	1.2 mm Steel
<b>Dimensions - Unpacked</b>							
Height	512 mm / 20.2"	562 mm / 22.1"	640 mm / 25.2"	675 mm / 26.6"	302 mm / 11.89"	266 mm / 10.47"	620 mm / 24.42"
Width Front	294 mm / 11.58"	344 mm / 13.54"	422 mm / 16.61"	250 mm / 9.84"	650 mm / 25.59"	850 mm / 33.46"	537 mm / 21.14"
Width Rear	294 mm / 11.58"	344 mm / 13.54"	422 mm / 16.61"	250 mm / 9.84"	650 mm / 25.59"	850 mm / 33.46"	537 mm / 21.14"
Depth	310 mm / 12.2"	333 mm / 13.1"	396 mm / 15.6"	300 mm / 11.9"	545 mm / 21.46"	670 mm / 26.38"	508 mm / 20.0"
<b>Dimensions - Packed</b>							
Height	580 mm / 22.83"	630 mm / 24.8"	705 mm / 27.76"	740 mm / 29.13"	365 mm / 14.37"	329 mm / 12.95"	685 mm / 26.97"
Width Front	348 mm / 13.7"	408 mm / 16.06"	482 mm / 18.98"	313 mm / 12.32"	715 mm / 28.15"	913 mm / 35.94"	600 mm / 23.62"
Width Rear	348 mm / 13.7"	408 mm / 16.06"	482 mm / 18.98"	313 mm / 12.32"	715 mm / 28.15"	913 mm / 35.94"	600 mm / 23.62"
Depth	358 mm / 14.09"	371 mm / 14.6"	433 mm / 17.04"	338 mm / 13.3"	605 mm / 23.82"	733 mm / 28.86"	575 mm / 22.64"
<b>Weight</b>							
Net Weight	13.6 kg / 29.9 lbs	16.7 kg / 36.7 lbs	22 kg / 48.4 lbs	17.8 kg / 39.2 lbs	37.7 kg / 82.9 lbs	44.6 kg / 98.1 lbs	35.5 kg / 78.1 lbs
Gross Weight	17 kg / 37.4 lbs	20 kg / 44 lbs	25 kg / 55 lbs	21 kg / 46.24 lbs	44 kg / 96.8 lbs	53 kg / 116.6 lbs	44 kg / 96.8 lbs



# 80 and 90 Series

WIDE DISPERSION INSTALLATION LOUDSPEAKERS FOR DRAMATIC STEREO IMAGERY



## 80 Series

An attractive 2 way system designed for wall or shelf mounting, equally at home in a portrait or landscape orientation.

The philosophy behind these loudspeakers is simple. To further extend Wharfedale's reputation for excellent sound quality whilst employing innovative design to give a distinctive yet discrete appearance to these loudspeaker systems.

Traditionally the loudspeaker placement in rooms has been dominated by the needs of stereo reproduction and consequently most positions are a compromise enforced by the directionality of conventional loudspeakers.

However, Wharfedale's innovative solution is to use the 'Baker Effect', a phenomenon first noted in the 1930's. By mounting two HF drive units perpendicular to each other, and carefully contouring the crossover network, Wharfedale has been able to reproduce a dramatic stereo effect in almost any listening position.



- Dual HF Drivers for 'Baker Effect'
- 8" Pulp Cone LF Drivers
- Ferrofluid Cooled Soft Dome HF Drivers
- Auto Resetting Thermal Overload Protection
- 4 Terminal Spring Clip Input Connectors

## Installation Speakers



- HF driver protection circuit
- Extensive mounting points
- High power output, low distortion sound quality
- Easy vertical or horizontal mounting
- M10 x 13 rigging points for easy installation



## 90 Series

Developed from the outstandingly successful 2180 series, the 90 series increases the choice of speakers available for this specialist application. The 90 series offers increased power handling and impressively high sound pressure levels from a range of compact boxes.

The transducers used in the 2090, 2190, 3190 & 4190 models are an 8 inch re-enforced pulp cone woofer and a 25 mm titanium dome HF unit, which is Ferrofluid cooled.

All models have auto-resetting thermal overload protection of the HF transducer as standard to ensure reliability and all models deliver a frequency range of 40 Hz to 20 kHz. The powerful 8 inch woofer uses a high temperature 2 inch voice coil and a selected pulp cone whilst the 25 mm titanium dome tweeter is loaded by a wide band horn; and is protected by a re-entrant thermal overload system.

The 2090, 2190, 3190 & 4190 cabinet exterior can be re-painted to match your venue interior and blend in with the environment. Whilst the units are of a strong and rugged nature, the weight is not unmanageable with the top, bottom and rear areas on all models clear for bracket mounting.

The 5090 and 5190 have a wide dispersion extra bass characteristic which is perfectly suitable for Karaoke applications. The 5090 & 5190 models are intended for wall mounting, though they can be stand mounted. They can also be flown using the fixing screws in the top. Both models are also available in a high quality piano finish (PU Version) for premium installation applications.



Model Name	2080	2180	3180	2090	2190	3190	4190	5090	5190
Frequency Response (+/-3 dB)	40 Hz - 20 kHz	40 Hz - 20 kHz	40 Hz - 20 kHz	40 Hz - 20 kHz	40 Hz - 20 kHz	40 Hz - 20 kHz	35 Hz - 20 kHz	40 Hz - 20 kHz	35 Hz - 20 kHz
Calculated Maximum SPL @1 m	90 dB	90 dB	92 dB	90dB	90 dB	93 dB	93dB	91dB	92 dB
<b>Low Frequency Transducer</b>									
Size (mm / inches)	200 mm / 8"	200 mm / 8"	2 x 200 mm / 8"	200 mm / 8"	200 mm / 8"	2 x 200 mm / 8"	2 x 200 mm / 8"	200 mm / 8"	2 x 200 mm / 8"
Voice Coil Size (mm / inches)	50 mm / 2"	50 mm / 2"	50 mm / 2"	50 mm / 2"	50 mm / 2"	50 mm / 2"	50 mm / 2"	50 mm / 2"	50 mm / 2"
Coil Size (mm / inches)	25 mm	2 x 25 mm	2 x 25 mm	25 mm	2 x 25 mm	2 x 25 mm	2 x 25 mm	2 x 25 mm	2 x 25 mm
Nominal Impedance	8 Ω	8 Ω	4 Ω	8 Ω	8 Ω	4 Ω	4 Ω	4 Ω	4 Ω
<b>Power</b>									
System Continuous Power (w)	50 w	50 w	90 w	100 w	100 w	175 w	175 w	175 w	250 w
System Programme Power (w)	100 w	100 w	175 w	200 w	200 w	350 w	350 w	350 w	500 w
System Peak Power (w)	200 w	200 w	350 w	400 w	400 w	700 w	700 w	700 w	1000 w
<b>Dimensions - Unpacked (mm)</b>									
Height	274 mm	274 mm	270 mm	270 mm	270 mm	270 mm	920 mm	576 mm	590 mm
Width Front	456 mm	456 mm	570 mm	445 mm	445 mm	445 mm	270 mm	368 mm	353 mm
Depth	200 mm	200 mm	290 mm	220 mm	250 mm	315 mm	255 mm	295 mm	310 mm



# XR Series

## POWER, PERFORMANCE AND....PRICE POINTS



Overcurrent, DC and Output Short Protection



Built-in Thermal Protection



Class AB & H Amplifier Design



Bridge Mode

## WELCOME TO THE NEW XR SERIES

The new XR series consists of 5 models. The XR3500, XR3000, XR2500, XR1500 and XR800 which deliver 1,000, 700, 500, 330 and 200 watts per channel into 8 Ω respectively.

All models feature XLR thru connectors, making cable management and daisy-chaining easy for installers or when used in flight cases. All models feature full circuitry protection for thermal, over current, DC, output short circuit along with power on/off muting. All models also feature ultra quiet variable speed fans.

Rear panel mode switches allow for selection between Parallel, Stereo and Bridge modes along with input sensitivity switching.

Large front air vents and steel construction aid heat dissipation to ensure the long life and reliable performance that comes with any Wharfedale Pro amplifier. Meanwhile, a huge toroidal transformer takes care of any AC power fluctuations.

XR amplifiers bring power and performance into a new price category.



## OPERATING MODE SWITCHES

There are 3 different operating modes switchable for the XR series amplifiers.

**STEREO** - Each channel remains independent. The amplifier may be used for two different signals.

**PARALLEL** - This connects both inputs together. One signal feeds both channels. Each channel's Gain control and loudspeaker connection remain independent.

**BRIDGE** - This combines both channels into a single channel with twice the output power.

- An affordable series of robust power amps
- Perfect for installation, touring and all live sound applications
- Heavy duty toroidal transformers
- Input sensitivity switching
- Full circuit protection

## Amplifiers



## SPECIFICATIONS

Model Name	XR800	XR1500	XR2500	XR3000	XR3500
<b>Stereo Power Output : RMS</b>					
8 Ω x 2	200 w	330 w	500 w	700 w	1000 w
4 Ω x 2	300 w	450 w	750 w	1000 w	1350 w
<b>Bridged Mono Power Output : RMS</b>					
8 Ω	600 w	900 w	1500 w	2000 w	2700 w
Frequency Response(+/-10 dB)	20 Hz - 20 kHz	20 Hz - 20 kHz	20 Hz - 20 kHz	20 Hz - 20 kHz	20 Hz - 20 kHz
Topology	Class AB	Class H	Class H	Class H	Class H Level - 3
Inputs	2 x XLR	2 x XLR	2 x XLR	2 x XLR	2 x XLR
Outputs	2 x NL4 (speakON compatible) 2 x XLR link	2 x NL4 (speakON compatible) 2 x XLR link	2 x NL4 (speakON compatible) 2 x XLR link	2 x NL4 (speakON compatible) 2 x XLR link	2 x NL4 (speakON compatible) 2 x XLR link
<b>Input Sensitivity &amp; impedance</b>					
Sensitivity	0.775 V or 1.4 V	0.775 V or 1.4 V	0.775 V or 1.4 V	0.775 V or 1.4 V	0.775 V or 1.4 V
Balanced XLR input Impedance	20 KΩ	20 KΩ	20 KΩ	20 KΩ	20 KΩ
Maximum Input Level	22 dBu (9.7 Vrms)	22 dBu (9.7 Vrms)	22 dBu (9.7 Vrms)	22 dBu (9.7 Vrms)	22 dBu (9.7 Vrms)
Voltage Gain	29 dB	31 dB	33 dB	36 dB	36 dB
Slew Rate	>10 V/us	>10 V/us	>10 V/us	>10 V/us	>10 V/us
Crosstalk	<-75 dB	<-75 dB	<-75 dB	<-75 dB	<-75 dB
S/N	>100 dB	>100 dB	>100 dB	>100 dB	>100 dB
Distortion (1 W)	<0.05%	<0.05%	<0.05%	<0.05%	<0.05%
Damping Factor (8 Ω), 10 Hz - 400 Hz	>200	>200	>200	>200	>200
Dimensions	482 mm x 88 mm x 325 mm	482 mm x 88 mm x 325 mm	482 mm x 88 mm x 325 mm	482 mm x 88 mm x 325 mm	482 mm x 88 mm x 390 mm
Net Weight	12.0 kg	13.3 kg	14.0 kg	14.1 kg	18.0 kg
Gross Weight	15.20 kg	16.35 kg	17.2 kg	17.3 kg	21.3 kg



# DP Series

LIGHT ON WEIGHT BUT VERY HEAVY ON.....POWER !



Suitable for professional live sound reinforcement or fixed installations, our DP series of digital amplifiers features 5 models that deliver between 595 watts and 3400 watts per channel into 4 Ω. Four of these new models are 4 channel amplifiers which allow installers to create discrete and versatile systems.

All models feature an advanced switch mode power supply and super-efficient Class D topology which delivers high power with low distortion.

The DP series are incredibly light in weight. Starting from only 8.14 kg, installers and performers will really appreciate the ease this brings to transportation.

## PROTECTION

A full suite of protection circuitry includes thermal, over-current, DC, short circuit protect and power on/off mute. This level of protection ensures long term system reliability and peace of mind should the worst ever happen.

The variable speed fans keep the amplifier rack quiet when not in use - and cool while its running at high volume.

- Super light weight
- 4 \* 4 channel models
- 1 \* Stereo model generating 6800 watts @ 8 Ω BTL.
- Ultra-quiet variable speed fans
- Advanced protection circuitry
- Class D topology
- Only 1U

## QUALITY COMPONENTS

Using Neutrik audio connectors and the highest quality internal fans, the DP series are not only light weight but extremely high quality.

Reliability of any amplifier is essential and DP series have been specifically developed to deliver high power outputs in extreme professional conditions.

## MODES AND SWITCHES

The DP Series feature stereo, bridge and mono modes. Use in bridge mode with an individual high-powered subwoofer or use a single multi-channel DP to power your whole sound system equally.

Mono mode saves external cabling by splitting a single input to feed two channels of the amplifier.

Gains can be controlled by the rear panel gain switch. This allows for installation into almost any rig or venue.

The DP Series features XLR inputs with a maximum input level of +22 dBu allowing for integration with any typical professional audio system.



Model Name	DP-4035	DP-4065	DP-4100	DP-4120	DP-2200
<b>Stereo Power Output</b>					
8 ohms	4 x 350 W	4 x 650 W	4 x 1000 W	4 x 1200 W	2 x 2000 W
4 ohms	4 x 595 W	4 x 1100 W	4 x 1700 W	4 x 2040 W	2 x 3400 W
2 ohms	4 x 1012 W	4 x 1870 W	4 x 2890 W	4 x 3468 W	2 x 4760 W
<b>Bridged Mono Output</b>					
16 ohms	2 x 700 W	2 x 1300 W	2 x 2000 W	2 x 2400 W	1 x 4000 W
8 ohms	2 x 1190 W	2 x 2200 W	2 x 3400 W	2 x 4080 W	1 x 6800 W
4 ohms	2 x 2023 W	2 x 3740 W	2 x 5780 W	2 x 6936 W	1 x 9520 W
<b>Input Sensitivity &amp; impedance</b>					
Sensitivity	selectable 35/32/29/26 dB	selectable 38/35/32/29 dB	selectable 38/35/32/29 dB	selectable 41/38/35/32 dB	selectable 41/38/35/32 dB
Balanced XLR input	20 Kohms	20 Kohms	20 Kohms	20 Kohms	20 Kohms
Maximum Input Level	15 dBu (4.3 Vrms)	15 dBu (4.3 Vrms)	15 dBu (4.3 Vrms)	15 dBu (4.3 Vrms)	15 dBu (4.3 Vrms)
Voltage Gain	35 dB	38 dB	38 dB	41 dB	41 dB
Slew Rate	>50 V / us	>50 V / us	>50 V / us	>50 V / us	>50 V / us
Crosstalk	<-90 dB	<-90 dB	<-90 dB	<-90 dB	<-90 dB
S/N	>103 dB	>105 dB	>107 dB	>108 dB	>109 dB
Distortion (1 W)	<0.05%	<0.02%	<0.02%	<0.02%	<0.02%
<b>Frequency Response</b>					
+/-1 dB @ 8 ohms				20 Hz - 20 KHz	
+/-3 dB @ 8 ohms				20 Hz - 30 KHz	
Damping Factor				>5000	
Topology				Class D	
<b>Connectors</b>					
Signal Input				Female XLR Jacks	
Power Output				SPEAKON Jacks	
<b>Controls</b>					
Front panel				AC Switch, 4xCH gain knobs	
Rear panel				Gain Switch; Mode Switch; Limiter Switch	
Protections				Thermal protect, Over-current protect, Output DC protect, Output short protect	
Indicators				Power, Mode, Temperature, Signal, Peak, Fault	
Cooling				Variable Speed Fan	
AC Power				90 - 260 VAC~, 50 - 60 Hz	
Dimensions	45x485x370 mm	45x485x370 mm	45x485x370 mm	45x485x465 mm	45x485x370 mm
<b>Carton Box</b>					
Weight (Net)	8.0 kg	9.1 kg	9.1 kg	12.2 kg	9.3 kg
Weight (Gross)	9.5 kg	10.6 kg	10.6 kg	14.8 kg	10.8 kg





# DP-D Series

SPECIFICATIONS THAT ARE HARD TO BELIEVE....BUT ARE TRUE!

**NEW**



The advanced multi-channel DP-D series power amplifiers use Class D topology to deliver enormous output power, all the way down to 2Ω. This makes them perfect for multi-loudspeaker systems such as line array.

Powerful internal DSP is accessible through the front panel, or through the supplied control software. This high quality DSP delivers granular editing of EQ, Limiting, Delay, Phase and Filtering to the signal path, allowing a DP-D amp to become the system controller as well as the power amplifier. This DSP removes the need for additional external signal processing.

Input connectivity is handled either by discrete analogue XLR connectors on the rear panel or by the RS485 connectors on the front which accept AES3 digital inputs.

Housed in a 1U rack, the DP-D models are compact, and lightweight but still bring huge power with extremely detailed levels of DSP control.

- Huge output power
- Stable down to 2 Ohms
- 4 channels
- Internal DSP
- RS485 for AES3 digital inputs
- Class D topology
- External software control
- Internal EQ, Limiting, Delay, Phase and filtering
- Ideal for line array and multi-speaker systems
- Lightweight and only 1U.
- Perfect for touring or fixed installations.

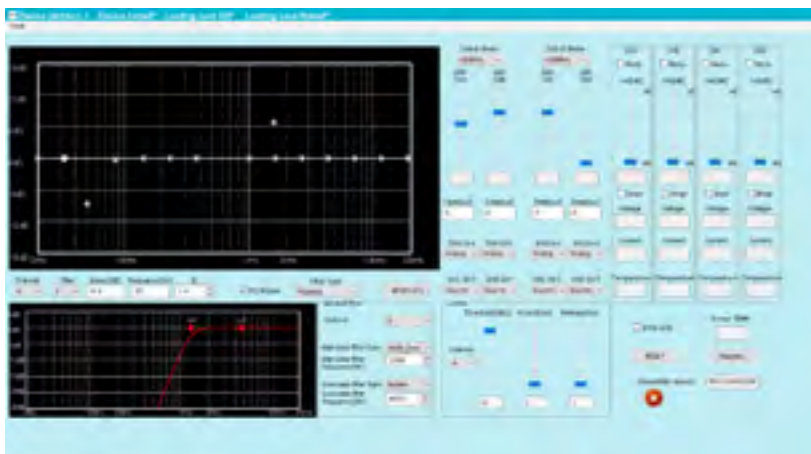

### Comprehensive DSP parameters

The internal DSP is powerful. This high quality DSP delivers granular editing of EQ, Limiting, Delay, Phase and Filtering to the signal path, allowing a DP-D amp to become the system controller .....as well as the power amplifier.

Housed in a 1U rack, the DP-D models are compact, and lightweight but still bring huge power with extremely detailed levels of DSP control.

## Amplifiers

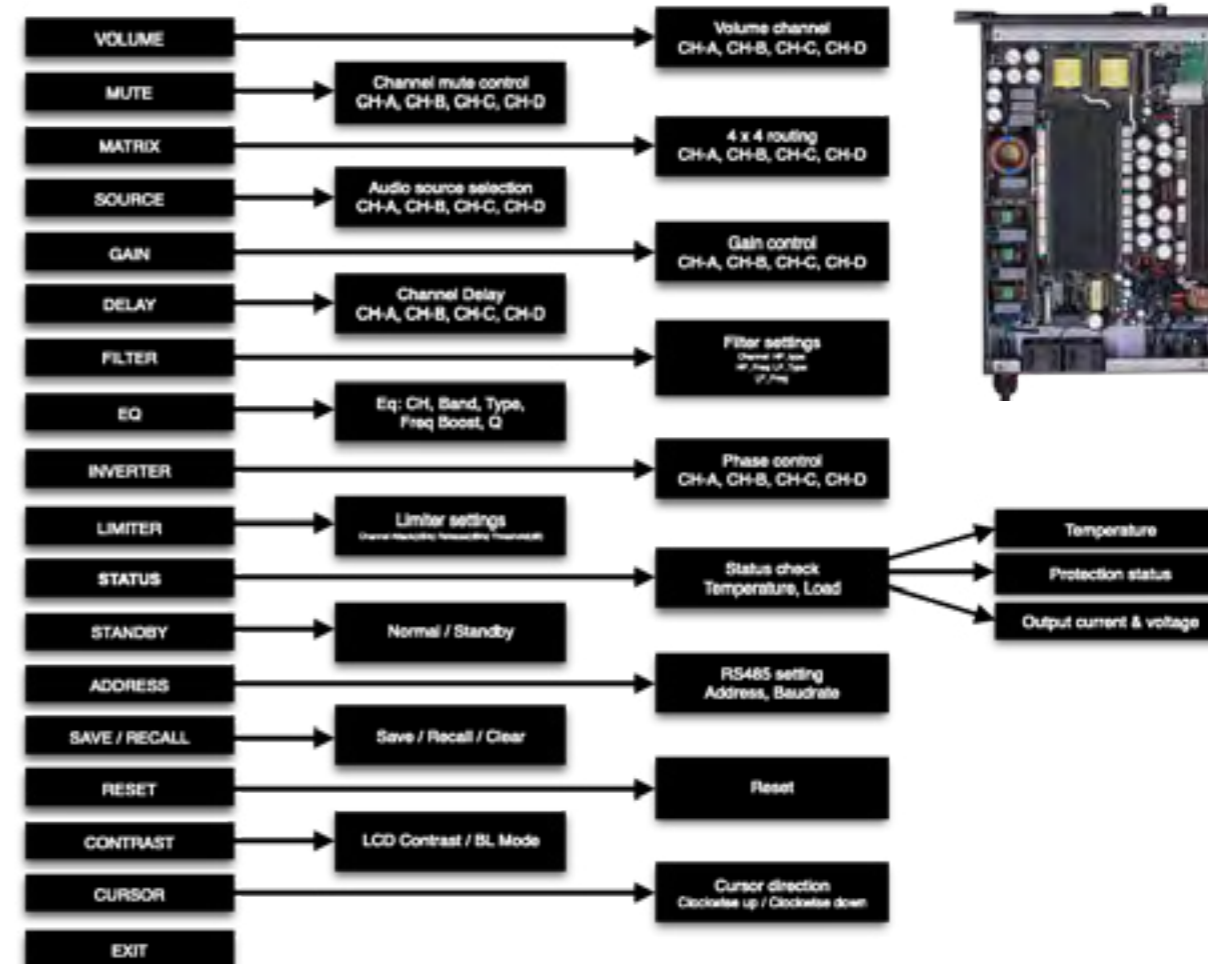

## SPECIFICATIONS

Model Name	DP- 4150D	DP- 4100D	
Rated Power (THD=1%, Each channel works simultaneously with continuous sinusoidal 1 KHz)	8 Ω/Stereo 4 Ω/Stereo 2 Ω/Stereo*	4 x 1500 W 4 x 2550 W 4 x 3570 W	4 x 1000 W 4 x 1700 W 4 x 2890 W
Output RMS voltage (THD=1%, 1 KHz)	16 Ω / Bridged 8 Ω / Bridged 4 Ω / Bridged*	2 x 3000 W 2 x 5100 W 2 x 7140 W	2 x 2000 W 2 x 3400 W 2 x 5780 W
Max. Input Level	109.5 V	89.4 V	8.7 Vrms(+21 dBu)(Default Gain)
Default Gain (Rated Power, 1 KHz)	25 dB	23 dB	23 dB
Gain range (Rated Power, 1 KHz)	23 dB ~ 41 dB	21 dB ~ 39 dB	21 dB ~ 39 dB
THD+N (10% Rated Power, typical)	0.05%	0.05%	0.05%
IMD-SMPTE (10% Rated Power, typical)	0.05%	0.05%	0.05%
DIM30 (10% Rated Power, typical)	0.05%	0.05%	0.05%
Crosstalk (20 Hz - 1 kHz, below Rated Power)	≥90 dB	≥90 dB	≥90 dB
Freq response (10% Rated Power, 20 Hz - 20 kHz, 8 Ω)	±0.2 dB	±0.2 dB	±0.2 dB
Input impedance	20 kΩ(Balanced), 10 kΩ(Unbalanced)	20 kΩ(Balanced), 10 kΩ(Unbalanced)	20 kΩ(Balanced), 10 kΩ(Unbalanced)
Damping factor (8 Ω, 20 Hz - 200 Hz)	≥1000	≥1000	≥1000
SNR (A weighted 20 Hz - 20 kHz)	≥105 dB (Default Gain)	≥105 dB (Default Gain)	≥105 dB (Default Gain)
Power supply	100 v ~ 240 VAC, 50 ~ 60 Hz	100 v ~ 240 VAC, 50 ~ 60 Hz	100 v ~ 240 VAC, 50 ~ 60 Hz
Protective Function	Power under-voltage protection; Amplifier output DC protection; Thermal Protection; Temperature Power Control; Overload Power Control	Power under-voltage protection; Amplifier output DC protection; Thermal Protection; Temperature Power Control; Overload Power Control	Power under-voltage protection; Amplifier output DC protection; Thermal Protection; Temperature Power Control; Overload Power Control
Size(Height×Width×Depth mm)	483x44x465 mm	483x44x370 mm	483x44x370 mm
Net Weight	13 kg	9 kg	9 kg

This power is measured by using a 20ms pulse of 1KHz sine wave at 1% total harmonic distortion.



# CPD Series

DRIVING EARTH SHAKING AUDIO FROM THE FRONT OF THE VENUE, ALL THE WAY TO THE BACK.



Overcurrent, DC and Output Short Protection



Built-in Thermal Protection



Class AB & H Amplifier Design



Bridge Mode



Lightweight



Built-in Limiter



## TECHNOLOGY

Working in stereo, parallel or bridged modes CPD is built for a multitude of sound system formations. Class AB (CPD1000 / CPD1600) and Class H (CPD2600 / CPD3600 / CPD4800) topology has resulted in a dynamic, high headroom amp made for propelling your loudspeakers through thick and thin with complete clarity.

## PROTECTION & DURABILITY

The CPD series is rife with technology that offers complete protection for your peace of mind. A built-in switchable limiter, allows over 8 Vrms signal through without distortion. In addition, it is equipped with thermal, overcurrent, DC and output short protect features.

## PRECISION CONTROL

Large rotary dials accurately adjust gain levels, and you will know when to do so from the clear and simple front panel. A 4 segment led formation displays shows vital power status, level, limit and protect information, keeping the sound engineer in the know.

## RELIABLE YET AFFORDABLE

Maximum headroom audio fidelity and durability are of course vital, whilst additionally we pride ourselves on unbeatable value. The CPD series is manufactured under our strict quality assurance as are all Wharfedale Pro products, making an amp you can trust from price to performance.



## OPERATING MODE SWITCHES

There are 3 different operating modes switchable for the CPD series amplifiers.

**STEREO** - Each channel remains independent. The amplifier may be used for two different signals.

**PARALLEL** - This connects both inputs together. One signal feeds both channels. Each channel's Gain control and loudspeaker connection remain independent.

**BRIDGE** - This combines both channels into a single channel with twice the output power.

- Class H topology (CPD2600 / CPD3600 / CPD4800)
- Class AB topology (CPD1000 / CPD1600)
- Suitable for mobile use, touring, rental and installation
- Stereo, Bridge and Parallel modes
- Switchable limiter
- Status and clip LEDs
- Thermal, overcurrent, DC & output short protect circuitry
- Continuously variable speed fans

## EASY TO CLEAN

Amplifiers often work in hot and dusty environments and, over time, the fans of an amp can easily suck this dirt in. Dirty cooling fans reduce efficiency and lead to overheating.

Its for this reason that we made our hardworking CPD series really easy to clean. Simply unscrew the front grille, brush off the air filters, and put the grille back on.

Very cool!



## MASSIVE TRANSFORMERS

CPD series are built around heavy-duty toroidal transformers.

These deliver smooth and consistent power into the amplifier circuits, resulting in stable and reliable audio output power.

## SPECIFICATIONS

Model Name	CPD1000	CPD1600	CPD2600	CPD3600	CPD4800
<b>Stereo Power Output : RMS</b>					
8 Ω x 2	230 w	400 w	650 w	870 w	1000 w
4 Ω x 2	350 w	620 w	1000 w	1300 w	1500 w
<b>Bridged Mono Power Output : RMS</b>					
8 Ω	700 w	1200 w	1940 w	2590 w	3000 w
4 Ω	1000 w	1600 w	2600 w	3600 w	4800 w
Frequency Response	20 Hz - 30 kHz	20 Hz - 30 kHz	20 Hz - 30 kHz	20 Hz - 30 kHz	20 Hz - 30 kHz
Topology	Class AB	Class AB	Class H	Class H	Class H
Inputs	2 x XLR	2 x XLR	2 x XLR	2 x XLR	2 x XLR
Outputs	2 x NL4 2 x XLR	2 x NL4 2 x XLR	2 x NL4 2 x XLR	2 x NL4 2 x XLR	2 x NL4, 2 x binding posts, 2 x XLR
<b>Input Sensitivity &amp; impedance</b>					
Sensitivity	0 dBu (0.775 Vrms)	0 dBu (0.775 Vrms)	0 dBu (0.775 Vrms)	0 dBu (0.775 Vrms)	0 dBu (0.775 Vrms)
Balanced XLR input	20 KΩ	20 KΩ	20 KΩ	20 KΩ	20 KΩ
Maximum Input Level	22 dBu (9.7 Vrms)	22 dBu (9.7 Vrms)	22 dBu (9.7 Vrms)	22 dBu (9.7 Vrms)	22 dBu (9.7 Vrms)
Voltage Gain	35 dB	37 dB	39 dB	41 dB	42 dB
Slew Rate	>40 V / us	>40 V / us	>40 V / us	>40 V / us	>40 V / us
Crosstalk	<-70 dB	<-70 dB	<-70 dB	<-70 dB	<-75 dB
S/N	>100 dB	>100 dB	>100 dB	>100 dB	>100 dB
Distortion (1 W)	<0.02%	<0.02%	<0.02%	<0.02%	<0.02%
Damping Factor	>300	>300	>300	>300	>300
<b>Controls</b>					
Front panel	AC Switch, CH 1 and CH 2 Gain Knobs				
Rear panel	Parallel, Stereo & Bridge Mode Switch; Limiter Switch				
Protections	Thermal protect, Over-current protect, Output DC protect, Output short protect, Power on/off mute				
Indicators	Power, Protect, Signal, Peak				
Cooling	Variable Speed Fan				
Dimensions	88 x 483 x 330 mm	88 x 483 x 330 mm	88 x 483 x 450 mm	88 x 483 x 450 mm	88 x 483 x 450 mm
Net Weight	11 kg / 24.25 lbs	13 kg / 28.66 lbs	19 kg / 41.88 lbs	22 kg / 48.50 lbs	23.5 kg / 51.80 lbs
Gross Weight	12.5 kg / 27.55 lbs	14.5 kg / 31.96 lbs	22.5 kg / 49.60 lbs	25.5 kg / 56.22 lbs	27 kg / 59.52 lbs

# MP Series

WITH HUGE TORIODAL TRANSFORMERS MP AMPS GO ALL THE WAY DOWN TO 2 Ω

-   
 Built-in Thermal Protection
-   
 Low impedance compatibility
-   
 Overcurrent, DC and Output Short Protection
-   
 Built To Last
-   
 High Quality Torroid Transformers



Suitable for portable sound reinforcement or fixed installations, our MP models deliver up to 2800 w into a 4 Ω load in a rugged 3U, 19" rack mount enclosure. Their advanced transformer power supplies deliver high power with low distortion.

MP series also happily operate with 2 Ω loads, making them ideal to drive multi-speaker rigs.

A full suite of protection includes thermal, over-current, DC, short circuit protect and power on/off mute. The MP Series features XLR inputs and linked outputs with a maximum input level of +22 dBu allowing integration with any typical professional audio system. The variable speed fans keep the amplifier rack quiet when not in use.

## OPERATING MODE SWITCHES

There are 2 different operating modes switchable for the MP series amplifiers.

### STEREO

Each channel remains independent. The amplifier may be used for two different signals.

### BRIDGE

This combines both channels into a single channel with twice the output power.



- MP2800: 950 W x 2 @ 4 Ω (RMS), 640 W x 2 @ 8 Ω (RMS), 2800 W @ 4 Ω (BTL)
- MP1800: 600 W x 2 @ 4 Ω (RMS), 300 W x 2 @ 8 Ω (RMS), 1800 W @ 4 Ω (BTL)
- Massive toroidal transformers
- 2 channels XLR inputs with link outputs
- 3 x NL4 (speakON compatible) outputs
- 2 operation modes (Stereo and Bridge)
- Power, Protect, Bridge and Peak indicators
- Thermal, over current, DC and output short protect.
- Power on/off mute
- Ultra quiet variable speed fans
- 3U rack mount chassis
- Operate down to 2 Ω to drive multiple loudspeakers

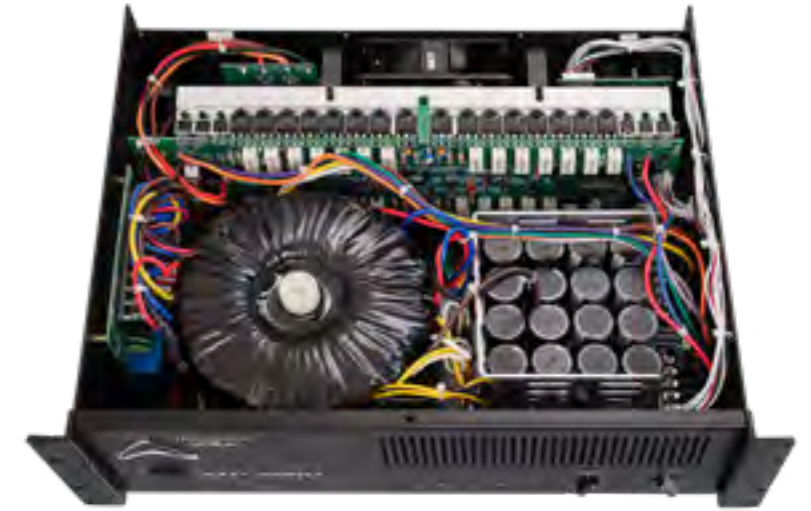

## SPECIFICATIONS

	MP1800	MP2800
<b>Model Name</b>	MP1800	MP2800
<b>Stereo Power Output</b>		
8 Ω x 2	300 W	640 W
4 Ω x 2	600 W	950 W
2 Ω x 2	900 W	1300 W
<b>Bridged Mono Power Output</b>		
8 Ω	1200 W	1900 W
4 Ω	1800 W	2800 W
Frequency Response	5 Hz - 30 kHz	5 Hz - 30 kHz
Topology	Class AB	Class H
Inputs	2 x XLR, 2 x 6.3 mm Jack	
Outputs	3 x NL4 (speakON compatible)	
<b>Input Sensitivity &amp; impedance</b>		
Sensitivity	+0 dBu (0.775 Vrms)	+0 dBu (0.775 Vrms)
Balanced XLR input	20 KΩ	20 KΩ
Maximum Input Level	22 dBu (9.7 Vrms)	22 dBu (9.7 Vrms)
Slew Rate	>30 V / us	>40 V / us
Crosstalk	<-70 dB	<-70 dB
S/N	>100 dB	>100 dB
Distortion (1 W)	<0.05%	<0.015%
Damping Factor	>300	>300
<b>Controls</b>		
Front panel	AC Switch, CH A and CH B Gain Knobs	
Rear panel	Stereo & Bridge Mode Switch	
Protections	Thermal protect, Over-current protect, Output DC protect, Output short protect, Power on/off mute	
Indicators	Power, Protect, Bridge, Peak	
Cooling	Variable Speed Fan	
Dimensions	132 x 494 x 464 mm	132 x 494 x 464 mm
Net Weight	23.5 kg / 51.80 lbs	25 kg / 55 lbs
Gross Weight	25 kg / 55.11 lbs	27.5 kg / 61 lbs



# Connect Series

SLIM, SMALL FOOTPRINT USB MIXERS WHICH ARE AT HOME IN THE STUDIO AS MUCH AS THEY ARE ON THE ROAD.



Professional features such as Phantom power and balanced XLR microphone inputs give you full functionality and great sound in an ultra compact and cost effective package.

The Microphone pre-amplifiers use the same high quality components and construction methods that are employed in our flagship mixers.

All CONNECT mixers feature an intuitive, ergonomically designed user interface that is excellent for beginners and professionals alike. Comprehensive connectivity ensures that a CONNECT mixer will fit into any situation you need.



- High quality microphone preamplifiers with switchable global +48 V phantom power
- Balanced XLR Mic/Mono inputs with input gain control
- Stereo Channels with Balanced/Unbalanced 6.3 mm jack inputs
- Pan/Balance controls for all channels
- Clip LED for all mono channels
- Separate Main Mix and Phones outputs with level controls
- Stereo 4 segment LED meters
- Stereo 6.3 mm headphone outputs
- Full duplex 16 bit / 48 kHz USB interface, with destination switches

## SPECIFICATIONS



Model Name	Connect 502USB	Connect 802USB	Connect 1002FX/USB	Connect 1202FX/USB
Channels	5	6	10	12
Inputs	1 x XLR, 5 x 6.3 mm jack	2 x XLR, 6 x 6.3 mm jack	2 x XLR, 10 x 6.3 mm jack	4 x XLR, 12 x 6.3 mm jack
Outputs	2 x 6.3 mm jack	2 x 6.3 mm jack	4 x 6.3 mm jack	4 x 6.3 mm jack
Headphone Output	6.3 mm jack	6.3 mm jack	6.3 mm jack	6.3 mm jack
FX	-	-	56 FX Logic Acoustic Modelling FX:Room, Plate, Hall and Gated Reverb. Chorus, Flanger, Rotary Speaker, Delay	56 FX Logic Acoustic Modelling FX:Room, Plate, Hall and Gated Reverb. Chorus, Flanger, Rotary Speaker, Delay
EQ	2-Band	3-Band	3-Band	3-Band
Phantom Power	Yes	Yes	Yes	Yes
USB	16 bit / 48 kHz	16 bit / 48 kHz	16 bit / 48 kHz	16 bit / 48 kHz
Signal To Noise Ratio	>78 dB ±5 dB @ Max Gain	>78 dB ±5 dB @ Max Gain	>78 dB ±5 dB @ Max Gain	>78 dB ±5 dB @ Max Gain
Frequency Response	20 Hz-20 kHz ±2 dB	20 Hz-20 kHz ±2 dB	20 Hz-20 kHz ±1 dB	20 Hz-20 kHz ±1 dB
Display	Dual 4-Segment LED	Dual 4-Segment LED	Dual 4-Segment LED, FX Setting Display	Dual 4-Segment LED, FX Setting Display
Dimensions	50.9 x 143 x 183.8 mm	50.9 x 208 x 183.8 mm	293.9 x 183.8 x 52.8 mm	360.2 x 183.8 x 52.8 mm
Weight	0.64 kg / 1.62 kg	0.92 kg / 1.9 kg	1.37 kg / 2.86 lbs	1.69 kg / 3.3 lbs



# SL Series

**STUDIO/LIVE MIXING CONSOLES WITH BUILT-IN FULL DUPLEX USB INTERFACING.**



Designed to cater for a wide range of mid format mixing duties, the SL Series includes many features suited to both live sound and home studio applications.

A high quality class-compliant 2-input 2-output 16-bit / 48 kHz USB interface features on all models, with larger models featuring a flexible record bus and dedicated return channel that is great for live and home recording.

Studio grade microphone preamps are used throughout the range and have balanced XLR inputs. All channels also deliver balanced/unbalanced TRS line level connectivity. In addition, all of the mono channels on larger models have a TRS insert point.

An ultra musical 3-band EQ is available on all channels, with an additional high pass filter on the mono channels. The SL824 USB and SL1224 USB feature a built in FX processor with 16 presets, giving unlimited creative potential. The on-board FX is supplemented by a dedicated FX send and 2 auxiliaries.



Model Name	SL424USB	SL824USB	SL1224USB
Channels	8	12	14
Inputs	4 x XLR, 8 x 6.3 mm jack	10 x XLR, 12 x 6.3 mm jack	12 x XLR, 14 x 6.3 mm jack
Outputs	2 x XLR, 2 x 6.3 mm jack	2 x XLR, 2 x 6.3 mm jack	2 x XLR, 2 x 6.3 mm jack
Headphone Output	6.3 mm jack	6.3 mm jack	6.3 mm jack
Auxiliary sends	1	2	2
FX	Send / Return	16x Effects: (1)Hall1 (2)Hall2 (3)Room1 (4)Room2 (5)Room3 (6)Platereverb1 (7)Platereverb2 (8)Platereverb3 (9)Chorus (10)Flange (11)Delay1 (12)Delay2 (13)Chorus/Room1 (14)Chorus/Room2 (15)Bypass (16)Rotaryspeaker	16x Effects: (1)Hall1 (2)Hall2 (3)Room1 (4)Room2 (5)Room3 (6)Platereverb1 (7)Platereverb2 (8)Platereverb3 (9)Chorus (10)Flange (11)Delay1 (12)Delay2 (13)Chorus/Room1 (14)Chorus/Room2 (15)Bypass (16)Rotaryspeaker
EQ	3 Band	3 Band with HPF	3 Band with HPF
Phantom Power	Yes	Yes	Yes
USB	16 bit / 48 kHz	16 bit / 48 kHz	16 bit / 48 kHz
Signal To Noise Ratio	-127 dBu ±5 dBu Mic Pre Equivalent Input Noise	-127 dBu ±5 dBu Mic Pre Equivalent Input Noise	-127 dBu ±5 dBu Mic Pre Equivalent Input Noise
Frequency Response	20 Hz - 20 kHz ±2 dB	20 Hz - 20 kHz ±2 dB	20 Hz - 20 kHz ±2 dB
Display	4 Segment Level LED with power and Phantom Power indicator	12 Segment Level LED with power and Phantom Power indicator	12 Segment Level LED with power and Phantom Power indicator
Dimensions: (H x W x D)	76 x 248 x 262 mm	80 x 400 x 369 mm	80 x 400 x 475 mm
Weight INCLUDES RACK MOUNT KIT	2.7 kg / 5.95 lbs	5.2 kg / 11.46 lbs	6.85 kg / 15.10 lbs

# FORCE 12

**WITH PORTABILITY AND POWER, FORCE 12 IS OUR LOUDEST POWERED MIXER.**



- 500 W x 2 @ 4 Ω (RMS)
- 300 W x 2 @ 8 Ω (RMS)
- 1300 W x 2 @ 4 Ω (Peak)
- Class D amplification
- 12 channels (8 mono & 2 stereo, play & record)
- 8 Mic inputs with switchable global +48V phantom power
- 3-band EQ control for each mono channel
- 2-band EQ control for each stereo channel
- Dual 7-band Graphic EQs with routing switch
- 10 channel peak LED indicators and 1 Effects peak LED indicator
- Dual 7-band Master Level LED indicators and 2 Limit LED indicators
- Mute button for all the Mic channels
- FX bypass button and FX Foot Switch to mute FX function
- 56 sorts of stereo effects with LED digital display
- Insert balanced/unbalanced 6.3 mm jacks for the built-in stereo amplifiers
- 5 low level outputs (Main L/R, Mon Send, FX Send and Sub Out-80 Hz LPF with 6.3 mm jacks and Record Output with RCA jacks)
- Thermal protect, over current protect, DC protect, and output short protect
- NL4 (speakON compatible) outputs for speakers

## SPECIFICATIONS



Model Name	FORCE 12
Channels	12
Inputs	8 x XLR, 10 x 6.3 mm jack, 2 x RCA phono
Outputs	2 x NL4 (speakON compatible), 8 x 6.3 mm jack, RCA
Power	4 Ω: 550 W RMS x 2 8 Ω: 290 W RMS x 2
Topology	Class D (SMPS)
Channel EQ	3 Band (2 Band on stereo channels)
FX	56 FX inc Reverb, Chorus, Flanger, Rotary Speaker & Delay
Phantom Power	Yes
USB	16 bit / 48 kHz
Noise	<0.005% @ 20 Hz-30 KHz MIC/LINE mono
Graphic equalizer	Dual 7 Band EQ
Display	Power, limit, signal and status LEDs
Dimensions (H x W x D)	540 x 330 x 330 mm
Net Weight	11 kg / 24.25 lbs



# PMX Series

LIGHTWEIGHT, COMPACT AND PORTABLE POWERED MIXERS



Designed to be a perfect balance of portability and power the PMX Series are suitable for use in a wide range of portable sound applications. Everything you need to mix and amplify microphones and line level sources is included in one box, with an ergonomic carry handle to aid transportation. The one box concept speeds up your setup time and allows you to start your performance quicker than ever before.



- Lightweight Class-D Amplifier Modules
- USB input and output (PMX 710)
- High-Efficiency Switch-Mode Power Supplies
- Phantom Powered Balanced XLR Mic Inputs
- XLR, 6.3 mm jack and RCA Inputs
- Peak Indicator for Each Channel
- Built-in Digital FX
- Clip LED display
- 7-Band Graphic EQ on Master Section
- 4 Segment LED Metering

## PMX 500 SYSTEM

The PMX 500 System comprises of a PMX 500 powered mixer, a pair of 2-way PTX-8 8" loudspeakers, a DM5.0s dynamic microphone and all the necessary cables to connect it all together.

- 1 \* PMX 500 powered mixer
- 2 \* Wharfedale Pro PTX-8 2-way loudspeakers
- 1 \* Wharfedale Pro DM5.0s dynamic microphone
- 1 \* 4.5 m microphone cable & 2 speaker cables
- 300 w peak



## PMX 700 SYSTEM

Comprised of a PMX 700 powered mixer, a pair of 2-way PTX-12 12" loudspeakers, a DM5.0s dynamic microphone and, once again, all the necessary cables to connect it all together.

- 1 \* PMX 700 powered mixer
- 2 \* Wharfedale Pro PTX-12 2-way loudspeakers
- 1 \* Wharfedale Pro DM5.0s dynamic microphone
- 1 \* 4.5 m microphone cable & 2 speaker cables
- 1000 w peak



Model Name	PMX 500	PMX 700	PMX 710
Channels	5	7	7
Inputs	4 x XLR, 5 x 6.3 mm jack, 2 x RCA Phono, USB	6 x XLR, 8 x 6.3 mm jack, 2 x RCA Phono, USB	6 x XLR, 6 x 6.3 mm jack, 2 x RCA Phono, USB
Outputs	2 x NL4 (speakON compatible) combi jack, 2 x RCA, 1 x 6.3 mm jack	2 x NL4 (speakON compatible) combi jack, 2 x RCA, 3 x 6.3 mm jack	2 x NL4 (speakON compatible) combi jack, 2 x RCA, 3 x 6.3 mm jack
Power	150 W RMS 4 Ω	150 W RMS x 2 4 Ω	250 W RMS x 2 4 Ω
Topology	SMPS+ Class D	SMPS+ Class D	SMPS+ Class D
Channel EQ	2 Band	3 Band	3 Band
FX	16 Effects (Hall1; Hall2; Room1; Room2; Room3; Plate Reverb1; Plate Reverb2; Plate Reverb3; Chorus; Flange; Delay1; Delay2; Chorus/Room1; Chorus/Room2; Vocal Cancel; Rotary Speaker)	16 Effects (Hall1; Hall2; Room1; Room2; Room3; Plate Reverb1; Plate Reverb2; Plate Reverb3; Chorus; Flange; Delay1; Delay2; Chorus/Room1; Chorus/Room2; Vocal Cancel; Rotary Speaker)	16 Effects (Hall1; Hall2; Room1; Room2; Room3; Plate Reverb1; Plate Reverb2; Plate Reverb3; Chorus; Flange; Delay1; Delay2; Chorus/Room1; Chorus/Room2; Vocal Cancel; Rotary Speaker)
Phantom Power	Yes	Yes	Yes
USB	No	No	Yes
Noise	±15 dB maximum	±15 dB maximum	±15 dB maximum
Graphic equalizer	7 band graphic EQ (60 Hz, 120 Hz, 480 Hz, 1 KHz, 4 KHz, 8 KHz, 16 KHz) ±12 dB gain	Dual 7 band graphic EQ (60 Hz, 120 Hz, 480 Hz, 1 KHz, 4 KHz, 8 KHz, 16 KHz) ±12 dB gain	Dual 7 band graphic EQ (60 Hz, 120 Hz, 480 Hz, 1 KHz, 4 KHz, 8 KHz, 16 KHz) ±12 dB gain
Display	Power, limit, signal and status LEDs	Power, limit, signal and status LEDs	Power, limit, signal and status LEDs
Dimensions (H x W x D)	392 x 261 x 243 mm	392 x 261 x 243 mm	392 x 261 x 243 mm
Net Weight	4.65 kg / 10.33 lbs	5.45 kg / 12 lbs	5.7 kg / 12.67 lbs



# Versadrive

CONTROL IS EVERYTHING.



Versadrive SC-24, SC-36 and SC-48

The Versadrive speaker management system offers all the digital signal processing and detailed control that a live sound engineer needs. Packaged into a neat 1U rack design, an intuitive and concise front panel with LCD screen enables engineers to make essential adjustments to the speaker configuration with accuracy.

Whether we like it or not, it's a reality that PA systems are complex. A lot of time is spent selecting the best loudspeaker and amplifier combinations, and systems can easily grow. Its therefore essential to maintain control to ensure the best quality sound throughout the rig.

Versadrive DSP Digital Matrix Processors puts that control at your fingertips (but can also be password protected to avoid giving up that control to inexperienced users!)

The new models are explained by their code numbers. SC-24 features 2 analog XLR inputs and 4 XLR analog outputs. SC-36 is a 3 in 6 out while the SC-48 delivers 4 in and 8 out.

All new models feature the same highest quality 24-bit 96 kHz AD/DA convertors and the internal DSP is handled by a 40-bit processor. All models deliver granular control over all aspects of audio. From input and output phase adjustment, delay timing, compression, limiting, parametric EQ, and multiple choices of HP and LP filtering, it's easy to tweak the parameters until the system is perfectly balanced.

For even more control, the new Versadrives are supplied with editing and librarian software. This allows for onscreen editing of all parameters and for setups to be backed up securely along with any other installation and touring documents that the Engineer needs.

With USB, RS232 and RS485 connectivity, Versadrive can be integrated into any system. As the system grows, so can Versadrive, and up to 255 units can be cascaded.

## Downloadable presets and documents

A comprehensive library of Versadrive presets and documents can be freely downloaded from [www.wharfedalepro.com](http://www.wharfedalepro.com)

These include meticulously created system setups for WLA series line arrays, FOCUS series and DELTA models. The presets make setting up any Wharfedale Pro system quick and easy and form the foundation of your system.

In addition, there are recommended system guide documents to help setup the perfect system.



SC-48



- 24-bit 96 kHz AD/DA convertors
- 40-bit internal processing
- USB / RS232 and RS485 connectivity
- User friendly Password protected front panel operation

## SPECIFICATIONS



Input Effects	Gain, Mute, Link, High-pass filter, Low-pass filter, Noise Gate, 8PEQ, 31 band graphic EQ, Phase, Delay
Output Effects	Crossover, SPEQ, Gain, Mute, Compressor / Limiter, Phase, Delay, Link
Software	Included via CD or download. Full matrix input output control. Intuitive UI.
User Presets	20
Total units linkable	255 via RS485 and optional wireless router
<b>Audio Inputs</b>	
SC-24	2 x Balanced XLR
SC-36	3 x Balanced XLR
SC-48	4 x Balanced XLR
<b>Audio Outputs</b>	
SC-24	4 x Balanced XLR
SC-36	6 x Balanced XLR
SC-48	8 x Balanced XLR
USB	1 (PC Control)
Ethernet	1
RS232 Port	1
Frequency Response	20 Hz - 20 kHz
S/N Ratio	>115 dB
Distortion (THD)	<0.005 at 1 kHz (0 dBu)
Max output level	+20 dBu
Impedance	<500 Ω
D/A Convertors	24-bit Sigma Delta
Sampling Rate	96 kHz
Display	20 x 2 LCD Parameter / Function Display, 5-Segment Led Level Display
Dimensions	480 x 50 x 45 mm
Weight	2.62 kg

<b>Model Name</b>	<b>SC-26</b>
Frequency Response (±0.5 dB)	20 Hz - 20 kHz
DSP	32 bit
A/D D/A Converter	24 bit / 96 kHz
S/N Ratio	>110 dB
Delay time range	0-1000 ms
Filter Types	Linkwitz-Riley, Bessel, Butterworth up to 48 dB/oct.
EQ	6-band parametric / low shelf / high shelf
Memory	30 save slots
Number of inputs	2
Number of outputs	6
Input connection	XLR
Output connection	XLR
PC connections	USB / 2 x RS485
Net Weight	3.6 kg / 7.94 lbs
Gross Weight	4.6 kg / 10.14 lbs
Product dimensions	44 x 482 x 190 mm



# DM Series mics

OUR TRIED-AND-TESTED RUGGED DYNAMIC MICROPHONES.



A collection of robust and great sounding dynamic mics made to cut through the mix for detailed live vocal performance. High SPL capabilities combined with a super cardioid pickup patterns means these microphone can produce high gain before feedback and a high signal to noise ratio.

## SOLID BUILD

We mount the microphone capsule in one of our most durable solid cast metal alloy housings. A gold plated XLR connector ensures quality and durability previously unseen at this price point.

## USE WITH LOUD SOUND SOURCES

High SPL capabilities and wide frequency responses also mean that DM series microphones can adapt themselves to particularly loud sound sources including guitar cabinets and drums for both live and studio environments alike. DM series mics are designed for real performers and sound engineers who love live, loud music. The capsule inside a DM series mic can withstand an extreme level SPL without distortion, keeping a clear sound for even the loudest of performers.

- Robust dynamic super cardioid microphones
- High SPL capabilities
- High performance capsules
- Low distortion
- Tailored for vocals
- Also suitable for drums, guitar cabs and other high SPL sound sources
- Rugged cast metal body
- Steel mesh grille
- Internal pop shield

## ONE.....

### DM5.0s

The classic single DM5.0s ships in a colour display box and is supplied with 1 x 5.0 meter XLR to XLR cable.

The supplied balanced cabling makes this ideal for connecting to audio mixers and amplifiers.



## Microphones

## TWO.....

### 3 PACK AVAILABLE TOO

The DM5.0s mic above is also available as a 3-pack. This includes a foam padded road-ready polypropylene carry case with 3 mic stand adapters.



## THREE.....

### DM5.0sj

The same classic DM5.0s mic but supplied with a 3.0 meter XLR to unbalanced 1/4" jack cable. Ideal for connecting to consumer amplification products.



## FOUR.....

### DM5.0Pro

When using a pro microphone on stage or in the studio, the Engineer must have control from the mixer desk. If a mic ON / OFF switch is changed without the Engineers knowledge, it can lead to big problems! The DM5.0Pro solves this problem. It has no switch. The DM5.0Pro is discrete on-stage and does not detract from the performance.

DM5.0Pro uses the same great sounding capsule from the DM5.0s. It also uses the same great road-ready construction as the DM5.0s but, without the potential confusion which can be caused by a switch.



## .....CHECK!

### DM-57

Using the same capsule and electronics as the classic DM5.0s, this new variant is something fresh. An all-new cosmetic design features a black body, yellow short throw switch and a silver pop shield.

A great sounding, all-round mic ideal for vocals, guitars, drums and brass. On stage or in the studio, DM-57 will deliver great sound and great 'fresh' looks for a lifetime.



Model Name	DM5.0s	DM5.0sj	DM5.0Pro	DM-57
Transducer type	Dynamic	Dynamic	Dynamic	Dynamic
Frequency Response	50 Hz - 12 kHz	50 Hz - 12 kHz	50 Hz - 12 kHz	50 Hz - 12 kHz
Polar Pattern	Super cardioid	Super cardioid	Super cardioid	Super cardioid
Output Impedance	600 Ω	600 Ω	600 Ω	600 Ω
Sensitivity	-52 dB (0 dB=1 V/Pa)	-52 dB (0 dB=1 V/Pa)	-52 dB (0 dB=1 V/Pa)	-52 dB (0 dB=1 V/Pa)
Off axis rejection	>20 dB at 180°	>20 dB at 180°	>20 dB at 180°	>20 dB at 180°
Maximum SPL	>135 dB	>135 dB	>135 dB	>135 dB
ON/OFF Switch	Yes - long throw	Yes - long throw	No	Yes - short throw
Switch colour	Red	Red	n/a	Yellow
Pop Shield colour	Black	Black	Black	Silver
Body colour	Grey	Grey	Grey	Black
Cable / Connector	3 pin gold plated male XLR	3 pin gold plated male XLR	3 pin gold plated male XLR	3 pin gold plated male XLR
Polarity	Pin 2 hot	Pin 2 hot	Pin 2 hot	Pin 2 hot
Housing	Solid cast metal alloy	Solid cast metal alloy	Solid cast metal alloy	Solid cast metal alloy
Supplied cable	5.0 meter XLR (f) -> XLR (m)	3.0 meter XLR (f) -> 6.3 mm unbalanced	5.0 meter XLR (f) -> XLR (m)	5.0 meter XLR (f) -> XLR (m)
Weight	300 g	300 g	300 g	300 g

# KMD-7 pack

A ONE STOP DRUM MICROPHONE PACKAGE GREAT FOR LIVE AND HOME STUDIO USE.



The KMD-7 pack consists of two KM3's, a KM4 and four KM5's.

These are Wharfedale Pro microphones specifically engineered for maximum coverage of a complete drum kit.

The mics are supplied in a durable plastic case with comprehensive foam padding to protect them from a lifetime on the road.

- Unidirectional polar responses
- Neodymium magnets (Except KM-3)
- Dent-resistant steel grilles
- Rugged cast Zinc alloy body
- Gold-plated XLR connector

## SPECIFICATIONS



Model Name	KM-3 (2 included)	KM-4 (1 included)	KM-5 (4 included)
Transducer type	Condensor	Dynamic	Dynamic
Frequency Response	30 Hz - 20 kHz	30 Hz - 12 kHz	50 Hz - 16 kHz
Polar Pattern	Cardioid	Super cardioid	Super cardioid
Output Impedance	<1000 Ω	250 Ω	250 Ω
Sensitivity	-46 dB (0 dB=1 V/Pa)	-54 dB (0 dB=1 V/Pa)	-54 dB (0 dB=1 V/Pa)
Off axis rejection	>18 dB at 180°	>20 dB at 180°	>22 dB at 180°
Maximum SPL	>120 dB	>135 dB	>130 dB
ON/OFF Switch	Yes	Yes	Yes
Cable / Connector	3 pin gold plated male XLR	3 pin gold plated male XLR	3 pin gold plated male XLR
Polarity	Pin 2 hot	Pin 2 hot	Pin 2 hot
Housing	Zinc alloy	Zinc alloy	Zinc alloy
Dimensions	30 x 154 x 21 mm	58.6 x 77.8 x 27 mm	45.2 x 61.3 x 24 mm
Weight	120 g	240 g	170 g

# WF-300

WIRELESS MICROPHONE SYSTEM  
...WITH EQ!



The new WF-300 Wireless Microphone system brings advanced digital signal transmission technologies together with the highest quality audio components to create a wireless mic system that is both simple to use and delivers great quality audio - over a long range!

- 5 x Internal EQ settings embedded inside mics
- Easy to change the EQ curve to suit the performer
- Long range - in excess of 100 m line of sight
- Simple IR syncing
- Large LCD backlit displays
- Robust dynamic mics with gyroscopic automate / unmute.
- 600-690 MHz and 863-865 MHz models
- 2 x 100 channels (600-690 MHz version)
- 2 x 4 channels (863-865 MHz version)

## EQ MODES

WF-300 features 5 specially tuned EQ settings embedded inside its microphones. These allow the user to adjust the EQ curve of the mics to suit the character of their voice. This makes using the WF-300 a pleasure and helps the performer feel 'comfortable' with their sound.

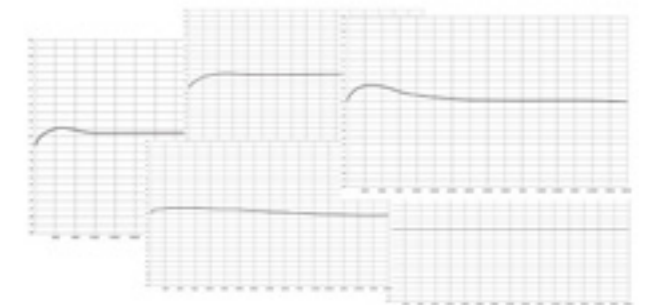

## CONSTRUCTION

The microphones themselves are made from robust alloy with a dent-resistant spring-steel grille. The LCD display inside the mic also helps the user to monitor the battery level and channel selections.

The mics also feature an internal gyroscope which senses movement making automute/unmute a seamless experience for the performer.

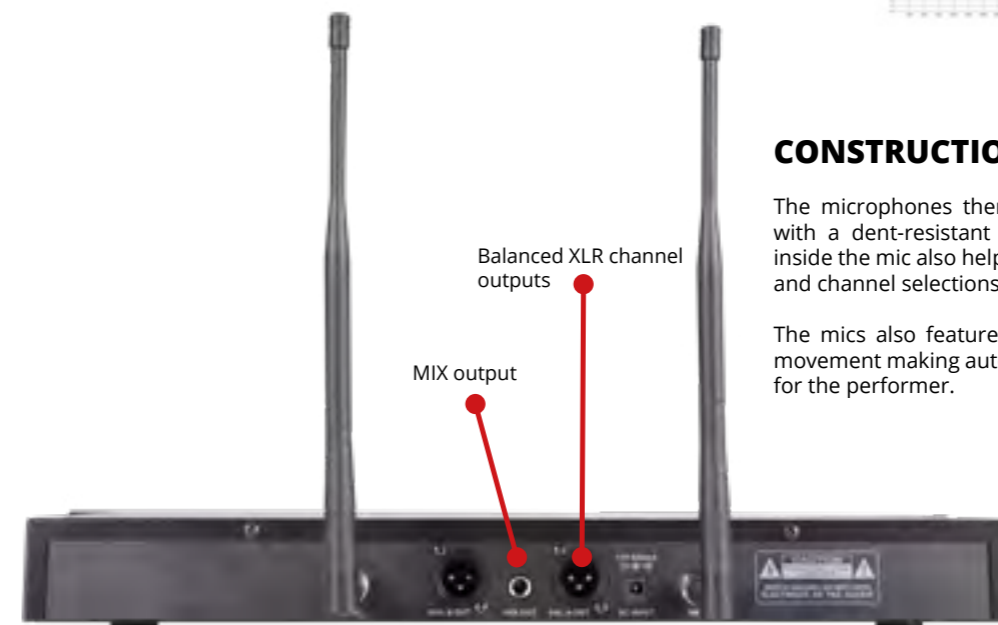



# AEROLINE VOCAL

## HANDHELD UHF WIRELESS MIC SYSTEM

### FOR THE VOICE

Made specifically for solo vocal performances, the Aeroline Vocal Wireless mic system delivers perfect vocal clarity over long distances, in a simple to use package.

A specially designed microphone capsule captures the detail and warmth of the voice, ensuring that the system gets the best possible quality audio input.

This signal is then transmitted to the 'small footprint' receiver with dual antennae using True Diversity technology. This results in a system which works over long distances without drop-outs.

Unique to products at this price point are the backlit LCD displays on both the mic and the receiver. This makes setup and control simple.

With its high quality capsule, superb long range performance and easy operation, Aeroline Vocal delivers everything the vocalist or presenter needs.



- Easy to setup with infrared syncing.
- True diversity system signal stability over long distances.
- Backlit LCD's on mic and receiver. Easy to see on-stage.
- High quality vocal microphone capsule design.
- Two versions available - 598-694 MHz or 863-865 MHz working frequency

Included items	AEROLINE VOCAL	AEROLINE VOCAL
Working frequency	863-865 MHz	598-694 MHz
Modulation mode	UHF	UHF
Channels	81	324
Operating distance	about 80 m (line of sight)	about 80 m (line of sight)
RF generator mode	PLL Frequency Synthesizer	PLL Frequency Synthesizer
RF bandwidth	2 MHz	96 MHz
RF frequency precision	+/- 10 ppm	+/- 20 ppm
Audio frequency response	50 Hz-16 KHz(200 mV input )	50 Hz-16 KHz
SNR	> 95 dB (A weighted)	> 90 dB (A weighted)
THD	<0.8% / 1 KHz (200 mV output )	<0.5% / 1 KHz (300 mV output )
<b>Transmitter</b>		
Dynamic range	> 95 dB	> 90 dB
Output Power	30 mW	10 mW
Display	LCD	LCD
Current consumption	<150 mA / 3 v	<180 mA / 3 v
Power supply	2 x AA or AA rechargeable batteries	2 x AA or AA rechargeable batteries
Transducer pickup head	Moving coil	Moving coil
Pickup mode	Super cardioid	Super cardioid
Sensitivity	< 55 dB ± 3 dB (0 dB = 1 V / Par at 1 KHz)	< 55 dB ± 3 dB (0 dB = 1 V / Par at 1 KHz)
Maximum SPL	> 105 dB SPL	> 105 dB SPL
Battery life	About 8 hours(related to the battery quality)	About 6 hours(related to the battery quality)
<b>Receiver</b>		
Sensitivity	-105 dBm	-95 dBm
Harmonic distortion	<0.5% / 1 KHz (200 mV output)	<0.5% / 1 KHz (300 mV output)
Display	LCD	LCD
Audio outputs	Balanced XLR plus 1/4" jack	Balanced XLR plus 1/4" jack
Power supply	12 V / 500 mA	12 V / 500 mA



# BRACKETS

## FOR THE PERFECT INSTALLATION

### WPB-1

The multiple rigging points on Titan 12, 15 and SI-X mean that the WPB-1 can be secured to the bottom of these loudspeakers. Steel construction and available in black or white finish.



### WPB-2

The WPB-2 is equipped for a wide range of Wharfedale Pro speakers and will work with other PA speakers which use a 35 mm speaker pole input. Steel construction and available in black or white finish.



### WPB-3

Perfect for Titan 8 and Titan 8A MKII. The WPB-3 is attached to an appropriate mounting surface using any suitable combination of the 10 mounting points that are provided. The loudspeaker is then attached to the bracket using 4 threaded inserts. A WPB-3 provides secure and versatile mounting with control over both pan and tilt, 0° to 40° of downward tilt are available.



### WPB-6

Ceiling bracket for all models of Titan 12. 360° rotation and 120° of adjustable angle.

Using the 3 top rigging points, this bracket has 360° rotation and 120° angle adjustment.

It has never been so quick and straightforward to install a Titan.

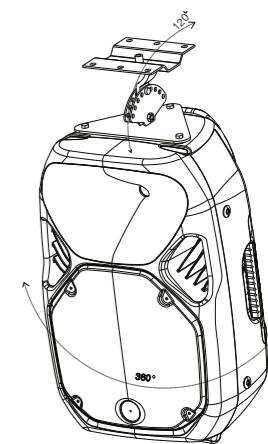

### WPB-T8

Customised U-Bracket for the Titan 8 (active or passive). Optimised for close-to-wall installation. Steel construction and available in black or white finish.



### WPB-T12

Customised U-Bracket for the Titan 12 (active or passive). Optimised for close-to-wall installation. Steel construction.



# POLES & CONTROLS

## HARDWEARING POLES FOR HARDWORKING RIGS

### SP-1X

The SP-1X speaker poles are just over a metre in length and are constructed from steel.

SP-1X is 35 mm in diameter at both ends.

It extends to 1340 mm and supports up to 50 kg.



### SP-2X

The SP-2X speaker poles are just over a metre in length and are constructed from steel.

SP-2X is 35 mm in diameter but uses an M20 at one end.

It supports up to 50 kg and extends to 1340 mm



### SP-3

The SP-3 uses barometric air pressure to aid smooth and safe raising and lowering.

With an M20 thread on its base and a 35 mm top, the SP-3 extends all the way to 1340 mm.

SP-3 supports up to 50 kg



### SP-4

The SP-4 features a practical crank with folding handle.

With an M20 thread on its base and a 35 mm top, the SP-4 extends to 1100 mm.

SP-4 supports up to 60 kg



### WPR-26 MKII

The WPR-26 MKII makes switching between passive loudspeakers simple and tidy. 2 dual channel power amplifiers can be connected as sources and 6 pairs of passive loudspeakers can be connected as destinations. High power handling relays (1000 W+) allow you to switch between sets of speakers without having to re-route signal cables.

A front panel display gives visual feedback from the WPR-26 MKII including which input is selected and which destination loudspeakers are active, there is also facility to mute all devices and use the left input channel only. The WPR-26 MKII is designed to allow only one active destination, to avoid overloading the source amplifier with low impedance loads.

An IR remote control allows a demonstrator or customer to easily switch between amps and speakers while in an optimal listening position. The IR receiver has a 6m long cable that enables the equipment rack to be kept away from the demonstration area.



# BAGS

## DURABLE PROTECTION FOR TRANSIT

### WLA-28 and WLA-210X Tourbags

Protect your WLA array system with the WLA-28 and WLA-210X tourbags.

Removeable panels and front grille allow the WLA element to be used even while in its protective padded covering. Ideal for rental and touring applications, these tourbags will keep your system safe and protected during its hardworking lifespan!

For WLA-28, WLA-210X and WLA-210XSUB.



### Typhon 12 Tourbags

Made from durable nylon and with a thick inner padding, this tourbag allows 12" Typhons (Typhon-AX12 and Typhon-AX12-BT) to be used in extreme conditions - protecting the Typhon during transportation. The tour bag has been designed to give full access to the handles and the rear panel connectors and controls. A removable front cover allows the Typhon to be used while inside the tourbag.

Durable, accessible and printed with the iconic Wharfedale Pro logo, the Typhon 12" tourbag is attractive and practical.

### Isoline 410 / 812 Tourbags

A hard-wearing durable Nylon fabric tourbag with 7mm internal padding to protect your PA system while on the road. The Isoline Tourbags feature carry-handle holes and elasticated edges for safe and secure transportation.

A convenient carry-pouch on the rear of the subwoofer tourbag is great place for accessory storage too.



### Titan Tourbags (for Titan 8", 12" and 15" models)

Titan Tourbags add exceptional protection to Titan Active or Passive speakers, and to keep the same ergonomics and convenience, the bag has been designed with removable front covers, rear panels, side panels and speaker pole sections so you can move and install your speaker without ever having to take the tourbag off.

The front cover removes to show a unique mesh material, which adds additional protection and leaves the sound unfettered.

### Tourus 12" and Tourus 15" Soft covers

Padded and branded, these protective soft covers for Tourus 12" and Tourus 15" models will not only keep your new Tourus active speaker protected from dust when its not being used but also provides protection during transportation.

Handy handle holes give easy access to all 3 of the handles of the Tourus.

